

1. Agenda Documents

Documents:

02-09-26 AGENDA.PDF
2026-01-26 MINUTES CC (DRAFT).PDF
2A PAYMENT OF BILLS.PDF
2B NEW HIRES AND DEPARTURES.PDF
2C PROPERTY.PDF
2D ST HENRY GAMBLING PERMIT.PDF
2E GAMBLING PERMIT MHS TOUCHDOWN BOOSTER CLUB.PDF
2F WC PHEASANT FOREVER GAMBLING PERMIT.PDF
2G KIDS HAVEN-MONTI PLATTING ENTITY.PDF
2H 2025 OPERATING TRANSFERS.PDF
2I GLOWFEST SPECIAL EVENT PERMIT.PDF
2J FREEZE YOUR BASS OFF FISHING TOURNAMENT.PDF
2K HAVEN RIDGE EXTENSION.PDF
2L ACCEPTANCE OF MEADOWBROOK UTILITIES.PDF
2M PLOW TRUCK PURCHASE.PDF
2N SCHOOL BLVD ROUNDABOUTS CHANGE ORDER.PDF
2O CSAH 39 PAVEMENT PRESERVATION SUPPORT.PDF
4A STATE-AID ADVANCE.PDF
4B HWY 25 BRIDGE MNDOT AGREEMENT.PDF
WCSO - JANUARY CFS REPORT.PDF
WCSO - JANUARY HOURS REPORT.PDF

1.1. Agenda Documents

Documents:

4A ADDITIONAL INFORMATION.PDF
4B ADDITIONAL INFORMATION.PDF

AGENDA
REGULAR MEETING – MONTICELLO CITY COUNCIL
Monday, February 9, 2026 – 6:30 p.m.
Mississippi Room, Monticello Community Center

CITY COUNCIL SPECIAL MEETING
(Academy Room)

5:00 – 6:00 p.m.	Highway 25 Corridor – MNDOT Update
6:00 – 6:15 p.m.	Confirmation on Council Direction for Water Treatment Plant Project

Mayor: Lloyd Hilgart
Council Members: Kip Christianson, Charlotte Gabler, Tracy Hinz, and Lee Martie

1. General Business

- A. Call to Order & Pledge of Allegiance
- B. Approval of Agenda – *Councilmembers or the City Administrator may add items to the agenda for discussion purposes or approval. The City Council may or may not take official action on items added to the agenda.*
- C. Approval of Meeting Minutes
 - Regular Meeting Minutes from January 26, 2026
- D. Citizen Comments – *Individuals may address the City Council about any item not contained on the agenda. Each speaker will be allotted three minutes with a maximum of five speakers. The Mayor may allow for additional time and/or speakers. The City Council generally takes no official action of items discussed, except for referral to staff for future report.*
- E. Public Service Announcements/Updates
- F. Council Liaison Updates
 - Planning Commission
 - Park, Arts, and Recreation Commission (PARC)
 - Central Mississippi River Partnership (CMRP)
- G. Department Updates
 - Response to citizen Comments from January 23 meeting

2. Consent Agenda – All items listed on the Consent Agenda are considered standard or may not need discussion prior to approval. These items are acted upon by one motion unless a councilmember, the city administrator, or a citizen requests the item by removed from consent for additional discussion.

- A. Consideration of approving payment of bills

- B. Consideration of approving new hires and departures for City departments
- C. Consideration of approving the disposal of surplus laptops for the IT Department
- D. Consideration of approving temporary gambling permit for Church of St. Henry for bingo and raffle to be held April 19, 2026, at Little Mountain Elementary, 9350 Fallon Avenue
- E. Consideration of approving the temporary gambling permit for the Magic MHS Touchdown Booster Club for the high school football program raffle being held on August 29, 2026, at the Monticello Country Club, 1209 Golf Course Road
- F. Consideration of approving a temporary gambling permit for Wright County Pheasants Forever for their annual banquet being held on March 21, 2026, at the Monticello Community Center
- G. Consideration of authorizing Kids Haven Monticello Holdings, LLC as the signatory applicant to the proposed Jefferson Commons Fifth Addition Preliminary and Final Plat related to a 2.93-acre childcare facility development proposal on City owned property while the purchase agreement is being finalized
- H. Consideration of approving 2025 operating transfers
- I. Consideration of approving a special event permit for MontiArts Glow Fest on February 28, 2026. Applicant: MontiArts
- J. Consideration of approving a special event permit authorizing the Parks, Arts, & Recreation Department, in partnership with the Swim Bait Club to host a fishing tournament and expo, including the use of the MCC Warehouse, on February 21, 2026
- K. Consideration of approving an extension to June 11, 2026, for the approval of the Preliminary Plat and Development Stage Planned Unit Development (PUD) and for City decision on the Haven Ridge West Final Plat and Final Stage PUD
- L. Consideration of adopting Resolution 2026-04 accepting public utilities for the Meadowbrook development
- M. Consideration of authorizing the purchase of a 2027 Volvo VHD Tandem Axle Cab and Chasses from Nuss Truck & Equipment equipped with Force America controls, a dump body and Falls plow equipment from Towmaster and purchase of associated auto greaser from Lubecore for a net cost of \$345,499.22 and declaring the current Truck 116 as surplus
- N. Consideration of approving Change Order #1 in the amount of \$40,487.38 with OMG Midwest, Inc. as part of the School Boulevard Intersection Improvements Project
- O. Consideration adopting Resolution 2026-05 supporting the Wright County Pavement Preservation Project on CSAH 39

2A. Consideration of items removed from the consent agenda for discussion

3. Public Hearings

4. Regular Agenda

- A. Consideration of adopting Resolution 2026-06 to advance Municipal State-Aid funds in the amount of \$2,225,718.49
- B. Consideration of adopting Resolution 2026-07 approving a MNDOT Cooperative Construction and Maintenance Agreement for TH 25 Bridge of I-94 Redecking Project

5. Adjournment

**MONTICELLO CITY COUNCIL
REGULAR MEETING MINUTES
Monday, January 26, 2026 – 6:30 p.m.
Mississippi Room, Monticello Community Center**

Present: Lloyd Hilgart, Kip Christianson, Charlotte Gabler, Tracy Hinz, and Lee Martie
Absent: None

1. General Business

A. Call to Order & Pledge of Allegiance

Mayor Hilgart called the meeting to order at 6:30 p.m.

B. Approval of Agenda

Councilmember Gabler requested that discussion on residential speed limits be added to the agenda.

Motion by Councilmember Hinz to approve the agenda with the addition of discussion on residential speed limits. Councilmember Christianson seconded the motion. Motion carried unanimously.

C. Approval of Meeting Minutes

- Joint Workshop Minutes from December 15, 2025
- Special Meeting Minutes from January 12, 2026
- Regular Meeting Minutes from January 12, 2026

Motion by Councilmember Gabler to approve the meeting minutes. Councilmember Hinz seconded the motion. Motion carried unanimously.

D. Citizen Comments

The following spoke under citizen comments:

Scott Custforth, 8634 Fairhill LN. Mr. Custforth requested that the City address a broken elevator at the Deep Haven Apartments (1255 Edmonson Avenue) and also expressed concern about potential legal and financial impacts of a proposed data center. He added that Councilmember Christianson stated that there was a risk of being sued or putting the City at risk of bankruptcy due to not allowing a data center.

Councilmember Christianson clarified that his previous comments were intended to highlight the importance of establishing clear rules for evaluating development

applications, noting that without such rules, the City could face legal challenges that limit flexibility and create long-term financial burdens.

Bill Saville, 873 97th Street NW. Mr. Saville, a retired mechanical engineer, shared his knowledge of data centers and raised concerns about the proposed location and timing, citing traffic, power and water usage, and public safety. He noted potential conflicts with Monticello's long-term infrastructure and suggested the City consider locally owned, employee-focused business models to support community growth.

Jenna Vandenboom 4414 87th St. NE. She expressed concern about litigation being used as a scare tactic to allow data centers and that the City is vulnerable to these large companies. She also questioned whether a moratorium on the ordinance was an option.

Holly Newman, 840 Powell Street, Big Lake. Ms. Newman noted that her mom lived in Monticello and asked whether proposed ordinance is primarily motivated by fear of a lawsuit and suggested allowing smaller data centers.

Mayor Hilgart responded he his support for the ordinance is based on principle, not fear of litigation.

Ty Weiss, 714 E. 7th Street. Ms. Weiss expressed concerns that a proposed data center could strain the local power supply, especially during extreme weather events, potentially causing outages for residents while the data center remains operational using backup power. She also raised concerns about increased electricity costs due to peak usage and questioned the ability to fully predict or mitigate these impacts.

E. Public Service Announcements

City Clerk Jennifer Schreiber provided the following public announcement:

- DMV Trailer and Motorcycle Registration due in February

F. Council Liaison Updates

- **Economic Development Authority (EDA)** – Councilmember Hinz reported that at the January 14 EDA meeting, a professional services contract for the downtown small area proposal was authorized, and a Homeowner Rehabilitation Loan Program using the State Aid Housing Assistance Fund was approved.
- **Monticello Orderly Annexation Board (MOAA Board)** – Community Development Director Angela Schumann reported that the group reviewed ordinance amendments that were presented at the January 26 City Council meeting. They will not take action on these amendments until a public hearing is held.

G. Department Updates

- **Wright County Sheriff's Office Quarterly Update** – Sergeant McMackins, WCSO, presented the quarterly update.
- **Building Department Update** – Chief Building Official Bob Ferguson presented the annual update of the Building Department.
- **Wright County Economic Development Partnership – Partner of the Year Award.** Jim Thares, Economic Development Manager, presented the Partner of the Year Award that Monticello was awarded from the Wright County Economic Development Partnership.

2. Consent Agenda:

Motion by Councilmember Gabler to approve the Consent Agenda. Councilmember Christianson seconded the motion. Motion carried unanimously.

- A. Consideration of approving the payment of bills. **Action taken: Approved the bill and purchase card registers for a total of \$1,167,609.53.**
- B. Consideration of approving new hires and departures for City departments. **Action taken: Approved the hires for the Monticello Community Center (MCC) and Streets Department and departures for Hi-Way Liquor and MCC.**
- C. Consideration of approving the sale/disposal of surplus city property. **Action taken: No report.**
- D. Consideration of approving two applications for two temporary gambling permits for Parenting With Grace, Inc. for events on March 7, 2026, at the American Legion, 304 Elm Street, and October 3, 2026, at River City Extreme, 3875 School Blvd. **Action taken: Approved both applications.**
- E. Consideration of approving the appointment of Erin Stein to the Parks, Arts, and Recreation Commission for a term to expire December 31, 2026. **Action taken: Approved the appointment.**
- F. Consideration of approving a request for Conditional Use Permit for Auto Repair – Major and a variance to City Code Section 153.091 Use-Specific Standards for door opening to service area garage on street frontage, for a project in a B-3 (Highway Business) District. Applicant: Mohammad Awad. **Action taken: Approved the Conditional Use Permit.**
- G. Consideration of adopting Resolution 2026-03 accepting improvements and authorizing final payment of \$12,319 to Jacon, LLC, for the 2020 Stormwater

Project. **Action taken: Adopted Resolution 2026-03 accepting improvements and authorizing final payment.**

- H. Consideration of authorizing the purchase of a 2024 HAMM HD14iVV asphalt roller for \$65,833.83 and declaring the 2002 Stone Wold Pack 3100 roller as surplus. **Action taken: Authorized the purchase.**

3. Public Hearing:

4. Regular Agenda:

- A. Consideration of approving Resolution 2026-02 adopting the Monticello Industrial Alternative Urban Areawide Review and adopting the Monticello Industrial Alternative Urban Areawide Review Mitigation Plan for a 550-acre industrial development study area including a light industrial scenario and a technology campus scenario that could include a data center and appurtenant uses

Community Development Director Angela Schumann provided an overview of the Monticello Industrial Alternative Urban Areawide Review (AUAR) and Mitigation Plan, noting that it evaluates potential environmental impacts of a proposed technology campus and light industrial uses in the Monticello Orderly Annexation Area. She explained that the process included public and agency review and that adoption of the AUAR and Mitigation Plan will guide future planning, zoning, and environmental review. The AUAR is valid for five years and may be amended if development exceeds the scenarios analyzed.

Councilmember Gabler asked about the process if no development occurs within five years. Ms. Schumann stated the AUAR may be updated if conditions change or allowed to lapse, particularly if other development plans or significant changes occur.

Councilmember Hinz questioned the accountability related to the mitigation plan. Ms. Schumann noted that the AUAR identifies responsible parties for mitigation measures. As development proposals are reviewed, the City will ensure the mitigation plan is followed and that all environmental review requirements are addressed by the appropriate parties.

Motion by Councilmember Gabler to adopt Resolution 2026-02 adopting the Monticello Industrial Alternative Urban Areawide Review and adopt the Monticello Industrial Alternative Urban Areawide Review Mitigation Plan for a 550-acre industrial development study area including a light industrial scenario and a technology campus scenario that could include a data center and

appurtenant uses. Councilmember Christianson seconded the motion. Motion carried unanimously.

5. Additional Items

Councilmember Gabler requested discussion on lowering residential speed limits, noting prior consideration in December 2020 and available engineering data for an updated review. The Council expressed no opposition, though Mayor Hilgart noted potential enforcement challenges. There was consensus of the City Council for staff to schedule a workshop to discuss residential speed limits.

6. Adjournment

The meeting was adjourned at 8:20 p.m.

Jennifer Schreiber _____

Attest: _____

City Administrator

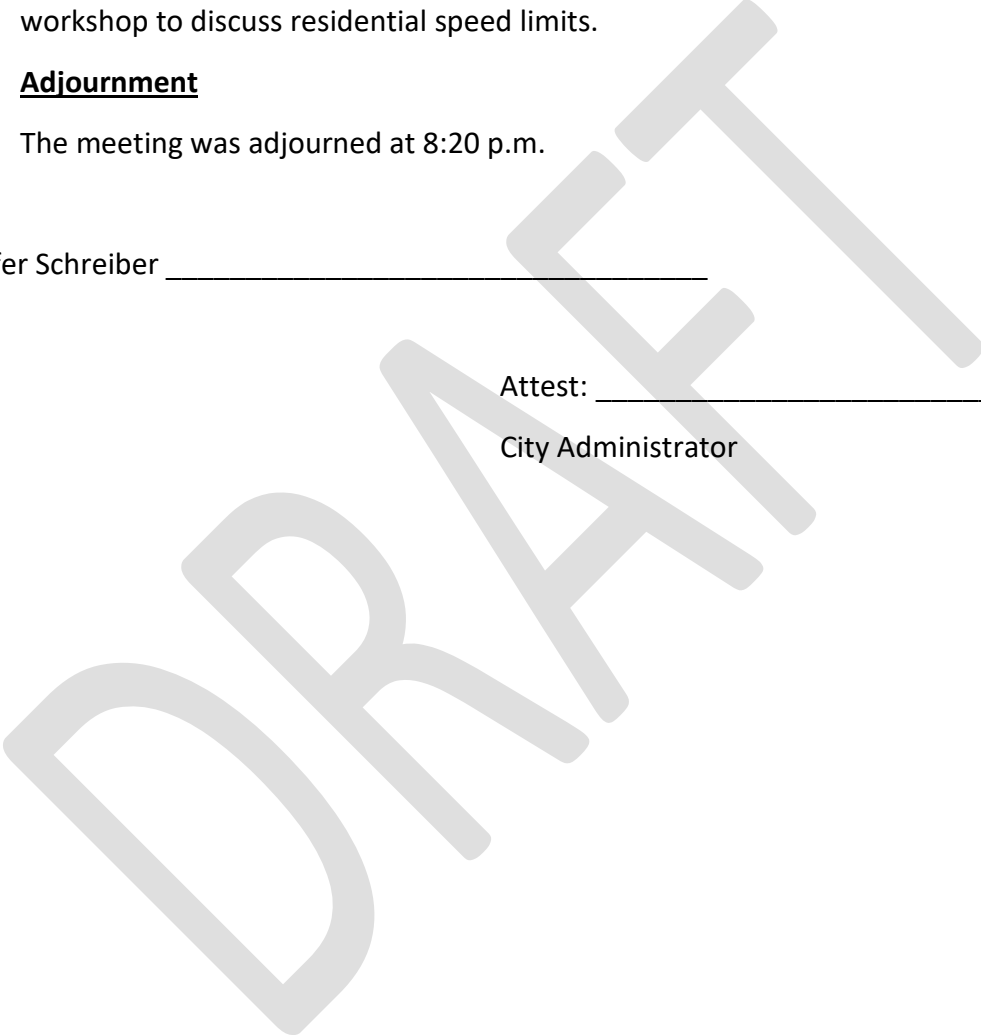

2A. Consideration of approving payment of bills

Prepared by: Finance Director	Meeting Date: 2/9/2026	<input checked="" type="checkbox"/> Consent Agenda Item <input type="checkbox"/> Regular Agenda Item
Reviewed by: N/A	Approved by: City Administrator	

ACTION REQUESTED

Motion to approve the bills for a total amount of \$1,126,533.88.

REFERENCE AND BACKGROUND

City staff submits the following items for approval by Council:

- \$ 114,930.44 Claims for recurring electronic payments including utilities*
- \$ 703,264.91 Claims for invoices received since last Council meeting*
- \$ 308,338.53 Payroll wages, taxes & benefits
- \$1,126,533.88

*Detailed listing included as supporting data

Subject to MN Statutes, most invoices require Council approval prior to releasing checks for payment. The day following Council approval, payments will be released unless directed otherwise. A credit purchasing agreement and policy was approved by Council initially and card purchases must comply with the policy.

If Council has no questions or comments on the bill and purchase card registers, these can be approved with the consent agenda. If requested, this item can be removed from consent and discussed prior to making a motion for approval.

- I. **Budget Impact:** N/A
- II. **Staff Workload Impact:** No additional work.
- III. **Comprehensive Plan Impact:** N/A

STAFF RECOMMENDED ACTION

City staff recommends approval of bill and purchase card registers as presented.

SUPPORTING DATA

- Bills registers

Accounts Payable

Checks by Date - Summary by Check Date

User: debbie.gulbrandson@monticellomn
Printed: 2/2/2026 3:43 PM



Check No	Vendor No	Vendor Name	Check Date	Check Amount
ACH	1102	CENTERPOINT ENERGY	01/31/2026	25,279.56
ACH	1585	XCEL ENERGY	01/31/2026	11,322.26
ACH	2050	DEMVI LLC	01/31/2026	213.86
ACH	4263	CAYAN	01/31/2026	1,690.65
ACH	5147	MN PEIP	01/31/2026	74,824.15
ACH	5646	JACK HENRY & ASSOCIATES, INC.	01/31/2026	57.52
ACH	6271	CLUB AUTOMATION - DAXCO LLC	01/31/2026	1,542.44
Total for 1/31/2026:				114,930.44
Report Total (7 checks):				114,930.44

The preceding list of bills payable was reviewed and approved for payment.

Date: 2/10/2026 Approved by: _____

Mayor Lloyd Hilgart

Accounts Payable

Checks by Date - Summary by Check Date

User: julie.cheney@monticellomn.gov
Printed: 2/5/2026 12:00 PM



Check No	Vendor No	Vendor Name	Check Date	Check Amount
ACH	1062	BEAUDRY OIL COMPANY	02/10/2026	4,072.83
ACH	1065	BELLBOY CORPORATION	02/10/2026	24,122.34
ACH	1074	BOLTON AND MENK INC	02/10/2026	1,971.00
ACH	1079	BOYER FORD TRUCKS - ST MICHAEL	02/10/2026	516.98
ACH	1091	CAMPBELL KNUTSON PA	02/10/2026	3,678.50
ACH	1129	DAHLHEIMER BEVERAGE LLC	02/10/2026	46,615.37
ACH	1153	ECM PUBLISHERS INC	02/10/2026	780.00
ACH	1205	GRAINGER INC	02/10/2026	391.01
ACH	1206	WINEBOW INC.	02/10/2026	174.00
ACH	1223	HAWKINS INC	02/10/2026	21,657.93
ACH	1273	KIWI KAI IMPORTS, INC.	02/10/2026	584.50
ACH	1303	M AMUNDSON CIGAR & CANDY CO, I	02/10/2026	2,193.19
ACH	1305	MACQUEEN EQUIPMENT LLC	02/10/2026	560.28
ACH	1377	MONTICELLO SENIOR CENTER	02/10/2026	5,833.33
ACH	1386	M-R SIGN CO INC	02/10/2026	2,511.22
ACH	1390	MTI DISTRIBUTING INC	02/10/2026	612.53
ACH	1411	OLSON & SONS ELECTRIC INC	02/10/2026	2,769.76
ACH	1417	OSC OXYGEN SERVICE COMPANY	02/10/2026	263.62
ACH	1453	SCP DISTRIBUTORS LLC	02/10/2026	174.40
ACH	1524	TK ELEVATOR	02/10/2026	832.11
ACH	1550	VEOLIA WATER N AM OPERATING SEI	02/10/2026	151,968.60
ACH	1552	VIKING COCA COLA BOTTLING CO	02/10/2026	752.90
ACH	1561	WATER LABORATORIES INC	02/10/2026	270.00
ACH	1567	WES OLSON ELECTRIC LLC	02/10/2026	1,490.00
ACH	1572	THE WINE COMPANY	02/10/2026	2,186.43
ACH	1584	WSB & ASSOCIATES INC	02/10/2026	35,473.25
ACH	1684	VINOCOPIA	02/10/2026	1,219.73
ACH	1698	LEE MARTIE	02/10/2026	105.00
ACH	1726	MARCO TECHNOLOGIES	02/10/2026	1,845.46
ACH	2041	WESTSIDE WHOLESALE TIRE & SUPP	02/10/2026	1,165.92
ACH	2080	CRYSTEEL TRUCK EQUIPMENT INC	02/10/2026	1,923.67
ACH	2154	FEDERATED CO-OPS INC	02/10/2026	121.60
ACH	2273	FIBERNET MONTICELLO - ACH	02/10/2026	1,772.61
ACH	2928	NUSS TRUCK AND EQUIPMENT	02/10/2026	14,983.98
ACH	3739	LLOYD HILGART	02/10/2026	210.00
ACH	4475	DAKOTA SUPPLY GROUP	02/10/2026	148.21
ACH	4502	ARVIG	02/10/2026	139.75
ACH	4633	PERFORMANCE FOOD GROUP INC	02/10/2026	1,371.29
ACH	4646	CAPITOL BEVERAGE SALES L.P.	02/10/2026	26,249.24
ACH	4660	SAFE-FAST, INC	02/10/2026	96.45
ACH	4691	MONTICELLO MEMORIALS, LLC	02/10/2026	250.00
ACH	4832	TIFCO INDUSTRIES, INC.	02/10/2026	793.69
ACH	4849	VON HANSON'S SNACKS INC	02/10/2026	97.20
ACH	4962	RENGEL PRINTING COMPANY, INC	02/10/2026	642.88
ACH	5201	DICK FAMILY, INC.	02/10/2026	3,317.19
ACH	5211	RANDI O'KEEFE KRIER	02/10/2026	2,187.50
ACH	5512	HYDROCORP HYDRO-DESIGNS, INC.	02/10/2026	1,180.83

Check No	Vendor No	Vendor Name	Check Date	Check Amount
ACH	5535	BOB FERGUSON	02/10/2026	1,880.00
ACH	5585	SBRK FINANCE HOLDINGS INC	02/10/2026	24.00
ACH	5635	WK & ASSOCIATES LLC	02/10/2026	870.00
ACH	5998	SADIE NIELSEN	02/10/2026	668.75
ACH	6251	STEPHEN W GRITTMAN	02/10/2026	4,617.20
ACH	6272	DANGEROUS MAN BREWING COMPA	02/10/2026	359.00
ACH	6654	OMG MIDWEST INC	02/10/2026	51,573.08
ACH	6797	VINCE KALEY	02/10/2026	150.00
ACH	6798	RICE LAKE CONTRACTING CORP	02/10/2026	48,410.00
131162	2925	1ST LINE/LEEWES VENTURES LLC	02/10/2026	482.25
131163	2820	CITY OF ALBERTVILLE	02/10/2026	500.48
131164	4696	AMERICAN PRESSURE INC	02/10/2026	1,508.95
131165	3491	ARTISAN BEER COMPANY	02/10/2026	171.10
131166	6732	ASCEN TEK CORP	02/10/2026	9,973.72
131167	1067	BERNICK'S	02/10/2026	4,338.57
131168	4328	BREAKTHRU BEVERAGE MN WINE &	02/10/2026	8,312.18
131169	2931	CENTRAL LOCKSMITH INC.	02/10/2026	70.00
131170	2440	DESIGN ELECTRIC INC	02/10/2026	386.84
131171	4010	MARILYN DIRKSWAGER	02/10/2026	440.00
131172	1455	DRAFT CONTROL INC	02/10/2026	162.12
131173	2015	KEITH A FRANKLIN	02/10/2026	537.64
131174	2008	BRETT HOLKER	02/10/2026	310.00
131175	6375	THE HOME CITY ICE COMPANY	02/10/2026	348.74
131176	4599	BOB IDZIOREK	02/10/2026	245.00
131177	3971	INTL UNION OF OPER ENGINEERS LO	02/10/2026	26,800.00
131178	1253	J H LARSON COMPANY	02/10/2026	2,842.19
131179	1263	JOHNSON BROTHERS LIQUOR CO.	02/10/2026	25,856.75
131180	1290	LEAGUE OF MINNESOTA CITIES	02/10/2026	1,180.00
131181	6243	M & M EXPRESS SALES & SERVICE	02/10/2026	1,048.30
131182	6790	MARK ELLIOT HOMES	02/10/2026	1,838.95
131183	2108	MN CITY/COUNTY MGMT ASSOCIATI	02/10/2026	350.00
131184	1349	MN DEPT OF TRANSPORTATION	02/10/2026	1,248.98
131185	1362	MN STATE FIRE CHIEFS ASSOC	02/10/2026	374.00
131186	1370	MONTICELLO DEPUTY REG #002	02/10/2026	1,211.25
131187	6677	OMNI PLUMBING	02/10/2026	3,480.00
131188	1427	PHILLIPS WINE & SPIRITS CO	02/10/2026	20,150.17
131189	1428	PINNACLE PUBLISHING, LLC	02/10/2026	795.00
131190	3818	POLLARDWATER.COM	02/10/2026	95.22
131191	5713	R.D.OFFUTT COMPANY	02/10/2026	65,833.82
131192	4148	SHERWIN WILLIAMS CO. #3442	02/10/2026	47.94
131193	4325	SNAP-ON INDUSTRIAL	02/10/2026	74.61
131194	3309	SOUTHERN GLAZER'S WINE AND SPII	02/10/2026	4,204.45
131195	6796	SQUEAKY SERVICES	02/10/2026	8,000.00
131196	4656	TRUE FABRICATIONS, INC.	02/10/2026	508.53
131197	3783	ULINE	02/10/2026	305.97
131198	4871	DAREK VETSCH	02/10/2026	140.00
131199	3992	WILLI HAHN CORPORATION	02/10/2026	26,706.80
131200	1573	WINE MERCHANTS INC	02/10/2026	1,554.08

Total for 2/10/2026: 703,264.91

Report Total (95 checks): 703,264.91

The preceding list of bills payable was reviewed and approved for payment.

Date: 2/10/26 Approved by: _____

2B. Consideration of approving new hires and departures for City departments

Prepared by: Human Resources Manager	Meeting Date: 2/9/2026	<input checked="" type="checkbox"/> Consent Agenda Item <input type="checkbox"/> Regular Agenda Item
Reviewed by: N/A	Approved by: City Administrator	

ACTION REQUESTED

Motion to approve new hires and departures for city departments.

REFERENCE AND BACKGROUND

The Council is asked to ratify the attached list of new hires and departures for the City. This listing includes full-time, part-time, seasonal, and temporary employees. The listing may also include status changes and promotions.

- I. **Budget Impact:** Positions are generally included in the budget.
- II. **Staff Workload Impact:** If new position, there may be some training involved. If terminated position, existing staff will cover hours as needed, until replacement.
- III. **Comprehensive Plan Impact:** N/A

STAFF RECOMMENDED ACTION

City staff recommends approval of new hires and departures as identified on the attached list.

SUPPORTING DATA

- List of new hires and terminated employees.

NEW EMPLOYEES

Name	Title	Department	Hire Date	Class
Edith Weinstein	Communications Specialist	Communications	2/3/2026	Temporary
Grace Christianson	Lifeguard	MCC	2/3/2026	PT
Jaclyn Troop	Guest Service Opener	MCC	2/3/2026	PT
Mercy Johnson	Supervised Play Attendant	MCC	2/4/2026	PT
Aubrey Trulock	Supervised Play Attendant	MCC	2/5/2026	PT
Megan Lindeman Hanson	Guest Service Assoc.	MCC	2/9/2026	PT

TERMINATING EMPLOYEES

Name	Reason	Department	Effective Date	Class
Jan Baumgarten	Voluntary	MCC	1/30/2026	PT
Stephanie Quade	Voluntary	DMV	2/21/2026	PT

2C. Consideration of approving the disposal of surplus laptops for the IT Department

Prepared by: City Clerk	Meeting Date: 2/9/2026	<input checked="" type="checkbox"/> Consent Agenda Item <input type="checkbox"/> Regular Agenda Item
Reviewed by: N/A	Approved by: City Administrator	

ACTION REQUESTED

Motion to approve the disposal of surplus laptops for the IT Department.

REFERENCE AND BACKGROUND

The Council is asked to declare certain items as surplus property and authorize the sale or disposal of those items. The IT Department would like to dispose of 27 laptops and 30 docking stations.

- I. **Budget Impact:** The value of the equipment.
- II. **Staff Workload Impact:** Minimal.
- III. **Comprehensive Plan Impact:** N/A

STAFF RECOMMENDED ACTION

City staff recommends approval of sale of surplus property.

SUPPORTING DATA

- A. Surplus List
- B. Picture

Equipment/Supplies Surplus List

Department: IT

Date: 2/9/2026

1. \$100,000 +
 - A.
 - B.
2. \$50,000 - \$100,000
 - A.
 - B.
3. \$25,000.00 - \$50,000.00
 - A.
 - B.
4. \$10,000 - \$25,000
 - A.
 - B.
 - C.
5. \$2,500 - \$10,000
 - A.
 - B.
 - C.
6. \$1,000 - \$2,500
 - A.
 - B.
 - C.
7. \$100 - \$1,000
 - A.
 - B.
 - C.
8. \$0 - \$100
 - A. 27 laptops (Dell Latitude 2590-1, Dell Latitude 3520-2, Dell Latitude 3510-25)
 - B. 30 Dell docking stations
 - C.



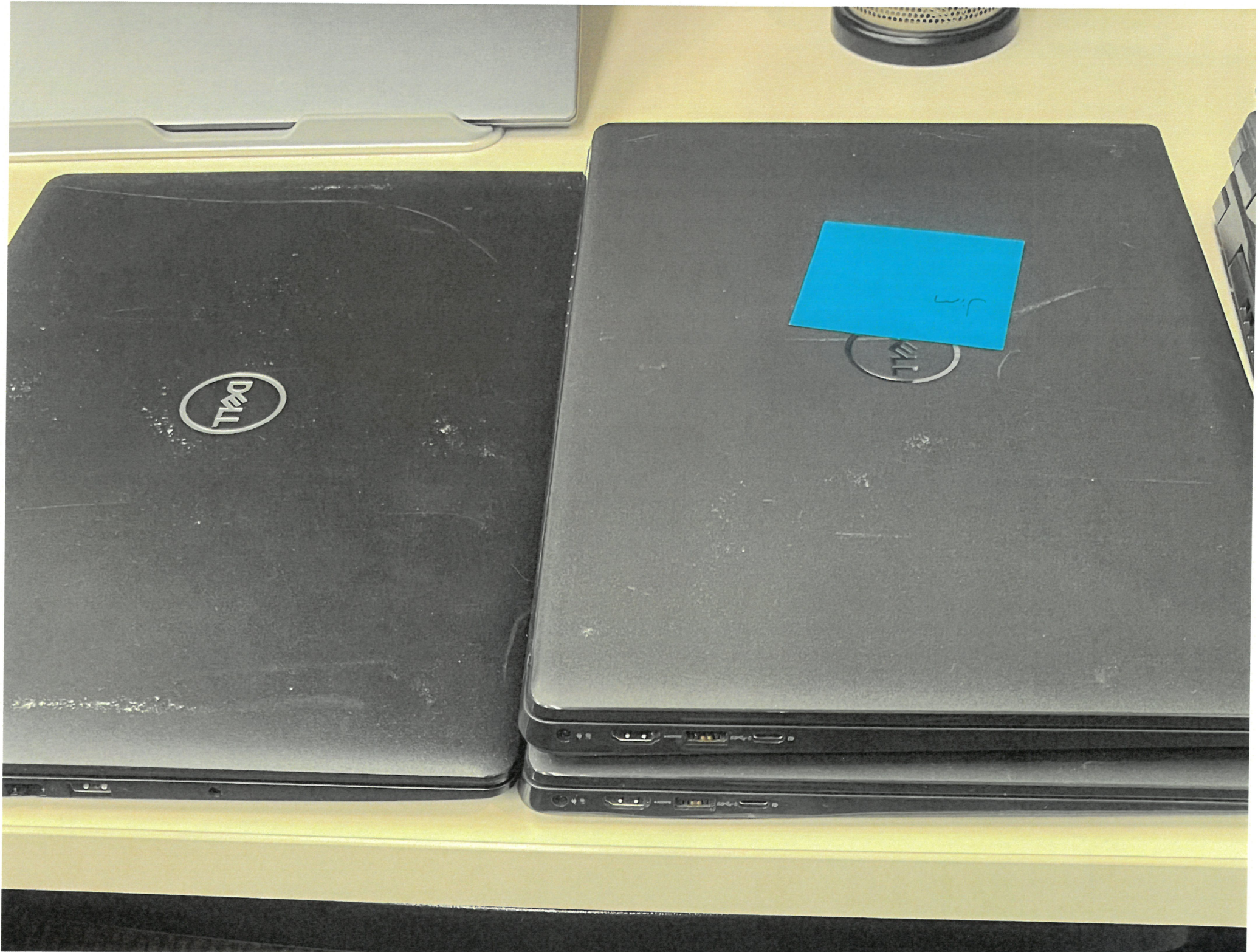

DELL

Lip

DELL

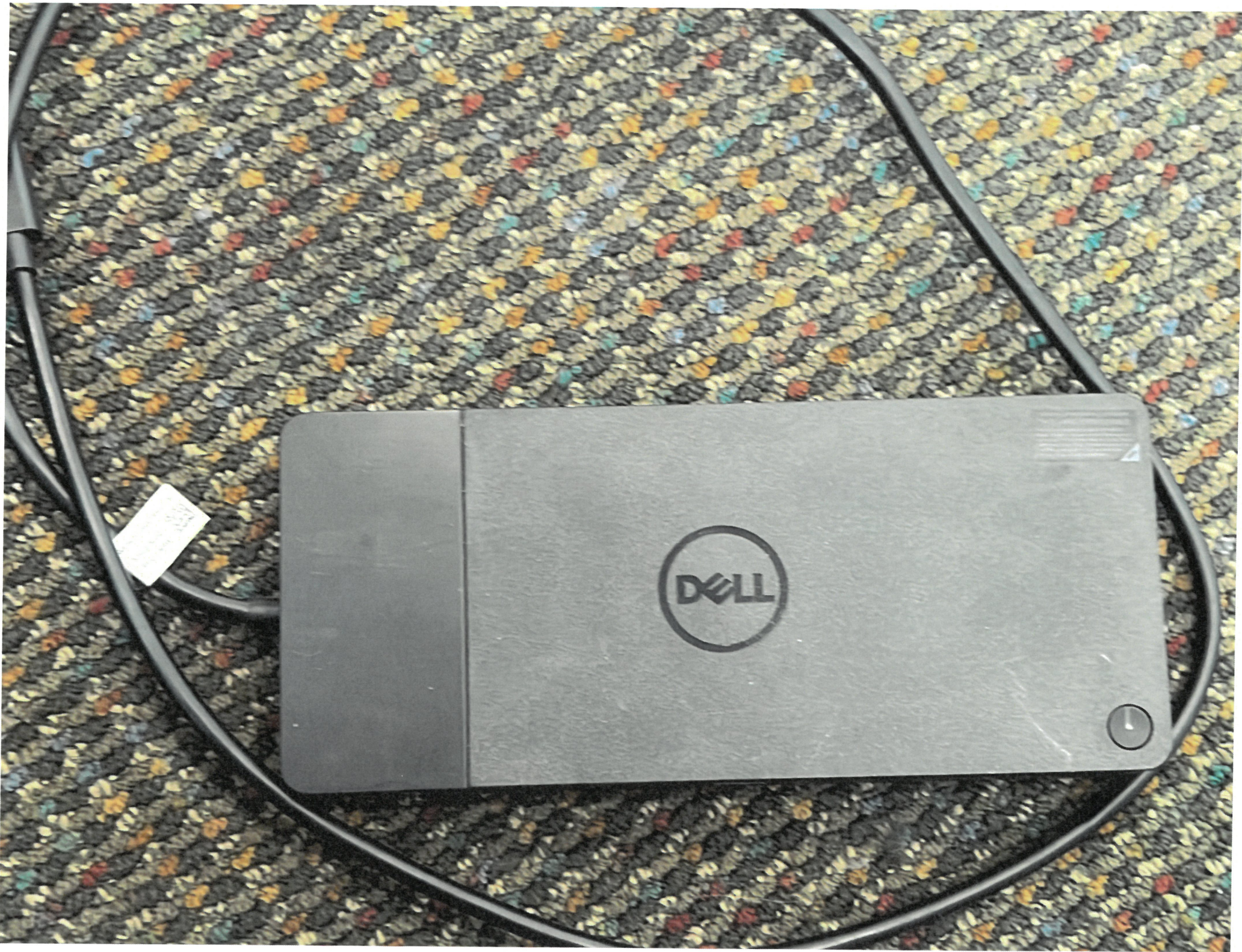

2D. Consideration of approving application from Church of St. Henry for a charitable gambling permit for bingo and a raffle being held on April 19, 2026, at Little Mountain Elementary, 9350 Fallon Avenue

Prepared by: City Clerk	Meeting Date: 2/9/2026	<input checked="" type="checkbox"/> Consent Agenda Item <input type="checkbox"/> Regular Agenda Item
Reviewed by: N/A	Approved by: City Administrator	

ACTION REQUESTED

Motion to approve the charitable gambling application submitted by Church of St. Henry.

REFERENCE AND BACKGROUND

The Church of St. Henry is requesting approval of a charitable gambling permit for bingo and a raffle to be held at Little Mountain Elementary on April 19, 2026.

To receive a permit from the State, the City must approve the gambling permit application. In the past, the City has not opposed these exempt gambling license applications for charitable events.

- I. **Budget Impact:** N/A
- II. **Staff Workload Impact:** Minimal administrative time.
- III. **Comprehensive Plan Impact:** N/A

STAFF RECOMMENDED ACTION

City staff recommend approving the charitable gambling permit.

SUPPORTING DATA

- Application

LG220 Application for Exempt Permit

An exempt permit may be issued to a nonprofit organization that:

- conducts lawful gambling on five or fewer days, and
- awards less than \$50,000 in prizes during a calendar year.

If total raffle prize value for the calendar year will be \$1,500 or less, contact the Licensing Specialist assigned to your county by calling 651-539-1900.

Application Fee (non-refundable)

Applications are processed in the order received. If the application is postmarked or received 30 days or more before the event, the application fee is **\$100**; otherwise the fee is **\$150**.

Due to the high volume of exempt applications, payment of additional fees prior to 30 days before your event will not expedite service, nor are telephone requests for expedited service accepted.

ORGANIZATION INFORMATION

Organization Name: Church of Saint Henry Previous Gambling Permit Number: X- 86019

Minnesota Tax ID Number, if any: 8507537 Federal Employer ID Number (FEIN), if any: 41-0764106

Mailing Address: 1001 E 7th St

City: Monticello State: MN Zip: 55362 County: Wright

Name of Chief Executive Officer (CEO): Rev. Patrick Barnes

CEO Daytime Phone: 763-295-2402 CEO Email: frbarnes@sthenrycatholic.com
(permit will be emailed to this email address unless otherwise indicated below)

Email permit to (if other than the CEO): mroberg@sthenrycatholic.com

NONPROFIT STATUS

Type of Nonprofit Organization (check one):

Fraternal Religious Veterans Other Nonprofit Organization

Attach a copy of one of the following showing proof of nonprofit status:

(DO NOT attach a sales tax exempt status or federal employer ID number, as they are not proof of nonprofit status.)

A current calendar year Certificate of Good Standing
Don't have a copy? Obtain this certificate from:
MN Secretary of State, Business Services Division
60 Empire Drive, Suite 100
St. Paul, MN 55103
Secretary of State website, phone numbers:
www.sos.state.mn.us
651-296-2803, or toll free 1-877-551-6767

IRS income tax exemption (501(c)) letter in your organization's name
Don't have a copy? To obtain a copy of your federal income tax exempt letter, have an organization officer contact the IRS toll free at 1-877-829-5500.

IRS - Affiliate of national, statewide, or international parent nonprofit organization (charter)
If your organization falls under a parent organization, attach copies of both of the following:
1. IRS letter showing your parent organization is a nonprofit 501(c) organization with a group ruling; and
2. the charter or letter from your parent organization recognizing your organization as a subordinate.

GAMBLING PREMISES INFORMATION

Name of premises where the gambling event will be conducted (for raffles, list the site where the drawing will take place): Little Mountain Elementary

Physical Address (do not use P.O. box): _____

Check one:

City: Monticello Zip: 55362 County: Wright

Township: _____ Zip: _____ County: _____

Date(s) of activity (for raffles, indicate the date of the drawing): April 19th, 2026

Check each type of gambling activity that your organization will conduct:

Bingo Paddlewheels Pull-Tabs Tipboards Raffle

Gambling equipment for bingo paper, bingo boards, raffle boards, paddlewheels, pull-tabs, and tipboards must be obtained from a distributor licensed by the Minnesota Gambling Control Board. EXCEPTION: Bingo hard cards and bingo ball selection devices may be borrowed from another organization authorized to conduct bingo. To find a licensed distributor, go to www.mn.gov/gcb and click on **Distributors** under the **List of Licensees** tab, or call 651-539-1900.

LG220 Application for Exempt Permit

LOCAL UNIT OF GOVERNMENT ACKNOWLEDGMENT (required before submitting application to the Minnesota Gambling Control Board)

<p style="text-align: center;">CITY APPROVAL for a gambling premises located within city limits</p> <p><input type="checkbox"/> The application is acknowledged with no waiting period.</p> <p><input type="checkbox"/> The application is acknowledged with a 30-day waiting period, and allows the Board to issue a permit after 30 days (60 days for a 1st class city).</p> <p><input type="checkbox"/> The application is denied.</p> <p>Print City Name: _____</p> <p>Signature of City Personnel: _____</p> <p>Title: _____ Date: _____</p> <div style="border: 1px solid black; padding: 5px; text-align: center; margin-top: 10px;"> <p>The city or county must sign before submitting application to the Gambling Control Board.</p> </div>	<p style="text-align: center;">COUNTY APPROVAL for a gambling premises located in a township</p> <p><input type="checkbox"/> The application is acknowledged with no waiting period.</p> <p><input type="checkbox"/> The application is acknowledged with a 30-day waiting period, and allows the Board to issue a permit after 30 days.</p> <p><input type="checkbox"/> The application is denied.</p> <p>Print County Name: _____</p> <p>Signature of County Personnel: _____</p> <p>Title: _____ Date: _____</p> <p>TOWNSHIP (if required by the county) On behalf of the township, I acknowledge that the organization is applying for exempted gambling activity within the township limits. (A township has no statutory authority to approve or deny an application, per Minn. Statutes, section 349.213.)</p> <p>Print Township Name: _____</p> <p>Signature of Township Officer: _____</p> <p>Title: _____ Date: _____</p>
--	---

CHIEF EXECUTIVE OFFICER'S SIGNATURE (required)

The information provided in this application is complete and accurate to the best of my knowledge. I acknowledge that the financial report will be completed and returned to the Board within 30 days of the event date.

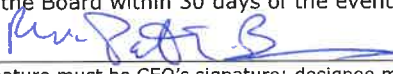
Chief Executive Officer's Signature:  Date: 1/9/26

(Signature must be CEO's signature; designee may not sign)

Print Name: Rev. Patrick Barnes

REQUIREMENTS	MAIL APPLICATION AND ATTACHMENTS
---------------------	---

Complete a separate application for:

- all gambling conducted on two or more consecutive days; or
- all gambling conducted on one day.

Only one application is required if one or more raffle drawings are conducted on the same day.

Financial report to be completed within 30 days after the gambling activity is done:
A financial report form will be mailed with your permit. Complete and return the financial report form to the Gambling Control Board.

Your organization must keep all exempt records and reports for 3-1/2 years (Minn. Statutes, section 349.166, subd. 2(f)).

Mail application with:

_____ a copy of your proof of nonprofit status; and
 _____ application fee (non-refundable). If the application is postmarked or received 30 days or more before the event, the application fee is **\$100**; otherwise the fee is **\$150**. Make check payable to **State of Minnesota**.

To: Minnesota Gambling Control Board
 1711 West County Road B, Suite 300 South
 Roseville, MN 55113

Questions?
 Call the Licensing Section of the Gambling Control Board at 651-539-1900.

<p>Data privacy notice: The information requested on this form (and any attachments) will be used by the Gambling Control Board (Board) to determine your organization's qualifications to be involved in lawful gambling activities in Minnesota. Your organization has the right to refuse to supply the information; however, if your organization refuses to supply this information, the Board may not be able to determine your organization's qualifications and, as a consequence, may refuse to issue a permit. If your organization supplies the information requested, the Board will be able to process the</p>	<p>application. Your organization's name and address will be public information when received by the Board. All other information provided will be private data about your organization until the Board issues the permit. When the Board issues the permit, all information provided will become public. If the Board does not issue a permit, all information provided remains private, with the exception of your organization's name and address which will remain public. Private data about your organization are available to Board members, Board staff whose work requires access to the information; Minnesota's Depart-</p>	<p>ment of Public Safety; Attorney General; Commissioners of Administration, Minnesota Management & Budget, and Revenue; Legislative Auditor, national and international gambling regulatory agencies; anyone pursuant to court order; other individuals and agencies specifically authorized by state or federal law to have access to the information; individuals and agencies for which law or legal order authorizes a new use or sharing of information after this notice was given; and anyone with your written consent.</p>
---	--	--

This form will be made available in alternative format (i.e. large print, braille) upon request.

2E. Consideration of approving temporary charitable gambling permit application for the Magic MHS Touchdown Booster Club for a raffle to be held August 29, 2026, at the Monticello Country Club, 1209 Golf Course Road

Prepared by: City Clerk	Meeting Date: 2/9/2026	<input checked="" type="checkbox"/> Consent Agenda Item <input type="checkbox"/> Regular Agenda Item
Reviewed by: N/A	Approved by: City Administrator	

ACTION REQUESTED

Motion to approve a temporary charitable gambling permit application for the Magic MHS Touchdown Booster Club, for a raffle on August 29, 2026.

REFERENCE AND BACKGROUND

The Magic MHS Touchdown Booster Club submitted an application for a temporary charitable gambling permit. This permit is for a raffle to be held August 29, 2026 at the Monticello Country Club for an annual tailgate party.

To receive a permit from the State, the City must approve the application.

STAFF RECOMMENDED ACTION

City staff recommend approving the temporary gambling permit.

SUPPORTING DATA

- Application

MINNESOTA LAWFUL GAMBLING
LG220 Application for Exempt Permit

An exempt permit may be issued to a nonprofit organization that:

- conducts lawful gambling on five or fewer days, and
- awards less than \$50,000 in prizes during a calendar year.

If total raffle prize value for the calendar year will be \$1,500 or less, contact the Licensing Specialist assigned to your county by calling 651-539-1900.

Application Fee (non-refundable)

Applications are processed in the order received. If the application is postmarked or received 30 days or more before the event, the application fee is **\$100**; otherwise the fee is **\$150**.

Due to the high volume of exempt applications, payment of additional fees prior to 30 days before your event will not expedite service, nor are telephone requests for expedited service accepted.

ORGANIZATION INFORMATION

Organization Name: Magic MHS Touchdown Booster Club Previous Gambling Permit Number: X- 95591-25-001

Minnesota Tax ID Number, if any: 20-3803070 Federal Employer ID Number (FEIN), if any: _____

Mailing Address: PO Box 4

City: Monticello State: MN Zip: 55362 County: Wright

Name of Chief Executive Officer (CEO): Andrew Kartak, Magic MHS Touchdown Booster Club President

CEO Daytime Phone: 612-600-0546 CEO Email: kartakandrew@gmail.com
(permit will be emailed to this email address unless otherwise indicated below)

Email permit to (if other than the CEO): shellymatuska1@gmail.com

NONPROFIT STATUS

Type of Nonprofit Organization (check one):

Fraternal Religious Veterans Other Nonprofit Organization

Attach a copy of one of the following showing proof of nonprofit status:

(DO NOT attach a sales tax exempt status or federal employer ID number, as they are not proof of nonprofit status.)

- A current calendar year Certificate of Good Standing**
Don't have a copy? Obtain this certificate from:
MN Secretary of State, Business Services Division Secretary of State website, phone numbers:
60 Empire Drive, Suite 100 www.sos.state.mn.us
St. Paul, MN 55103 651-296-2803, or toll free 1-877-551-6767
- IRS income tax exemption (501(c)) letter in your organization's name**
Don't have a copy? To obtain a copy of your federal income tax exempt letter, have an organization officer contact the IRS toll free at 1-877-829-5500.
- IRS - Affiliate of national, statewide, or international parent nonprofit organization (charter)**
If your organization falls under a parent organization, attach copies of both of the following:
1. IRS letter showing your parent organization is a nonprofit 501(c) organization with a group ruling; and
2. the charter or letter from your parent organization recognizing your organization as a subordinate.

GAMBLING PREMISES INFORMATION

Name of premises where the gambling event will be conducted
(for raffles, list the site where the drawing will take place): Monticello Country Club

Physical Address (do not use P.O. box): 1209 Golf Course Rd

Check one:

City: Monticello Zip: 55362 County: Wright

Township: _____ Zip: _____ County: _____

Date(s) of activity (for raffles, indicate the date of the drawing): August 29, 2026

Check each type of gambling activity that your organization will conduct:

Bingo Paddlewheels Pull-Tabs Tipboards Raffle

Gambling equipment for bingo paper, bingo boards, raffle boards, paddlewheels, pull-tabs, and tipboards must be obtained from a distributor licensed by the Minnesota Gambling Control Board. EXCEPTION: Bingo hard cards and bingo ball selection devices may be borrowed from another organization authorized to conduct bingo. To find a licensed distributor, go to www.mn.gov/gcb and click on **Distributors** under the **List of Licensees** tab, or call 651-539-1900.

LG220 Application for Exempt Permit

LOCAL UNIT OF GOVERNMENT ACKNOWLEDGMENT (required before submitting application to the Minnesota Gambling Control Board)

<p style="text-align: center;">CITY APPROVAL for a gambling premises located within city limits</p> <p><input type="checkbox"/> The application is acknowledged with no waiting period.</p> <p><input type="checkbox"/> The application is acknowledged with a 30-day waiting period, and allows the Board to issue a permit after 30 days (60 days for a 1st class city).</p> <p><input type="checkbox"/> The application is denied.</p> <p>Print City Name: _____</p> <p>Signature of City Personnel: _____</p> <p>Title: _____ Date: _____</p> <div style="border: 1px solid black; padding: 5px; text-align: center; margin-top: 20px;"> <p>The city or county must sign before submitting application to the Gambling Control Board.</p> </div>	<p style="text-align: center;">COUNTY APPROVAL for a gambling premises located in a township</p> <p><input type="checkbox"/> The application is acknowledged with no waiting period.</p> <p><input type="checkbox"/> The application is acknowledged with a 30-day waiting period, and allows the Board to issue a permit after 30 days.</p> <p><input type="checkbox"/> The application is denied.</p> <p>Print County Name: _____</p> <p>Signature of County Personnel: _____</p> <p>Title: _____ Date: _____</p> <p>TOWNSHIP (if required by the county) On behalf of the township, I acknowledge that the organization is applying for exempted gambling activity within the township limits. (A township has no statutory authority to approve or deny an application, per Minn. Statutes, section 349.213.)</p> <p>Print Township Name: _____</p> <p>Signature of Township Officer: _____</p> <p>Title: _____ Date: _____</p>
--	---

CHIEF EXECUTIVE OFFICER'S SIGNATURE (required)

The information provided in this application is complete and accurate to the best of my knowledge. I acknowledge that the financial report will be completed and returned to the Board within 30 days of the event date.

Chief Executive Officer's Signature: _____ Date: _____
(Signature must be CEO's signature; designee may not sign)

Print Name: Andrew Kartak, Magic MHS Touchdown Booster Club President

REQUIREMENTS	MAIL APPLICATION AND ATTACHMENTS
---------------------	---

<p>Complete a separate application for:</p> <ul style="list-style-type: none"> • all gambling conducted on two or more consecutive days; or • all gambling conducted on one day. <p>Only one application is required if one or more raffle drawings are conducted on the same day.</p> <p>Financial report to be completed within 30 days after the gambling activity is done: A financial report form will be mailed with your permit. Complete and return the financial report form to the Gambling Control Board.</p> <p>Your organization must keep all exempt records and reports for 3-1/2 years (Minn. Statutes, section 349.166, subd. 2(f)).</p>	<p>Mail application with:</p> <p>_____ a copy of your proof of nonprofit status; and _____ application fee (non-refundable). If the application is postmarked or received 30 days or more before the event, the application fee is \$100; otherwise the fee is \$150. Make check payable to State of Minnesota.</p> <p>To: Minnesota Gambling Control Board 1711 West County Road B, Suite 300 South Roseville, MN 55113</p> <p>Questions? Call the Licensing Section of the Gambling Control Board at 651-539-1900.</p>
---	--

<p>Data privacy notice: The information requested on this form (and any attachments) will be used by the Gambling Control Board (Board) to determine your organization's qualifications to be involved in lawful gambling activities in Minnesota. Your organization has the right to refuse to supply the information; however, if your organization refuses to supply this information, the Board may not be able to determine your organization's qualifications and, as a consequence, may refuse to issue a permit. If your organization supplies the information requested, the Board will be able to process the</p>	<p>application. Your organization's name and address will be public information when received by the Board. All other information provided will be private data about your organization until the Board issues the permit. When the Board issues the permit, all information provided will become public. If the Board does not issue a permit, all information provided remains private, with the exception of your organization's name and address which will remain public. Private data about your organization are available to Board members, Board staff whose work requires access to the information; Minnesota's Depart-</p>	<p>ment of Public Safety; Attorney General; Commissioners of Administration, Minnesota Management & Budget, and Revenue; Legislative Auditor, national and international gambling regulatory agencies; anyone pursuant to court order; other individuals and agencies specifically authorized by state or federal law to have access to the information; individuals and agencies for which law or legal order authorizes a new use or sharing of information after this notice was given; and anyone with your written consent.</p>
---	--	--

This form will be made available in alternative format (i.e. large print, braille) upon request.

<p style="text-align: center;">How You May Spend Gambling Funds</p>	<p style="text-align: center;">How You May Not Spend Gambling Funds</p>
<p>Allowable expenses - Gambling funds may be spent for allowable expenses, such as:</p> <ul style="list-style-type: none"> • gambling equipment (pull-tabs, bingo paper, bingo blower, paddlewheel tickets, tipboard games); • advertising; • printing raffle tickets; or • any services or goods that are directly related to the conduct of your gambling. <p>Charitable contributions - Gambling funds may be spent for the following charitable contributions (lawful purpose):</p> <ul style="list-style-type: none"> • to or by 501(c)(3) organization and 501(c)(4) festival organizations; • relieving the effects of poverty, homelessness, or disability; • problem gambling programs approved by the Minnesota Department of Human Services; • public or private nonprofit school; • scholarships (if a contribution is made to a scholarship fund, it must be made to a nonprofit organization whose primary mission is to award scholarships); • church; • recognition of military service (open to public or active military personnel in need); • activities and facilities benefiting youth under age 21; • citizen monitoring of surface water quality, with data submitted to Minnesota PCA; • unit of government (NOTE: A direct contribution to a law enforcement or prosecutorial agency is not allowed); • wildlife management projects or activities that benefit the public-at-large, with DNR approval; • grooming and maintaining snowmobile or all-terrain trails that are grant-in-aid trails, or other trails open to public use, with DNR approval; • supplies and materials for DNR training and educational programs; • nutritional programs, food shelves, and congregate dining programs primarily for persons who are 62 or older or disabled; • community arts organizations or programs; • humanitarian service recognizing volunteerism or philanthropy; and • acquisition and repair of real property and capital assets (contact the Gambling Control Board for requirements). 	<ol style="list-style-type: none"> 1. Controlled contribution - An organization may not retain any control over any contribution made from gambling funds. The only exception is for expenditures by a 501(c)(3) organization or a 501(c)(4) festival organization to its general fund. 2. Financial gain - A contribution or expenditure may not be made if it results in any monetary, economic, financial, or material benefit to the organization making the contribution or expenditure. 3. Government - An expenditure may not be made for: <ul style="list-style-type: none"> • influencing the nomination or election of a candidate for public office; • promoting or defeating a ballot question; or • any activity intended to influence an election or a governmental decision-making process. 4. Law enforcement - A direct contribution may not be made to a law enforcement or prosecutorial agency. 5. Pension - A contribution may not be made to a government pension or retirement fund, such as a fire relief association. 6. Conflict of interest - A contribution or expenditure may not be made if it is not allowed under the conflict of interest provisions of the Minnesota Nonprofit Corporation Act, Minnesota Statutes, Section 317A.255. 7. Alcohol - An expenditure may not be made for the purchase of any intoxicating liquor, wine, or malt beverages. 8. Fundraising - An expenditure may not be made for fundraising costs, except as allowed for a 501(c)(3) organization or 501(c)(4) festival organization from its general fund. 9. Other organizations - With few exceptions, gambling funds may not be contributed to other organizations or clubs such as veterans, fraternal, Lions, etc. unless it is a 501(c)(3) organization. 10. Other contributions - A contribution may not be made to a 501(c)(3) organization or another entity with the intent or effect of not complying with lawful purpose restrictions or requirements.

BINGO AND RAFFLE – Checklist for Excluded/Exempt Permits

The purpose of this form is to help your organization conduct excluded/exempt gambling in compliance with the requirements listed below. Exempt and Excluded activities cannot be conducted in the same calendar year. The five forms of lawful gambling are bingo, paddlewheels, pull-tabs, raffles and tipboards. Detailed information regarding each requirement is available by clicking on the following links [in blue italics]: 1) applicable statutes and rules; 2) the [Lawful Gambling Manual](#); 3) the online class, “[Conduct of Raffles](#)”; and 4) the [phone number and email address](#) of your county’s Licensing (license, permits and leases) and Compliance (conduct and reporting) Specialists.

Check Box	RAFFLES
	1. Tickets are printed in accordance with MN Rule 7861.0310 .
	2. Tickets contain the sequential number of the raffle ticket. Theatre style tickets may be used. (349.173)
	3. A list of prizes and a statement of other relevant information is made available to ticket purchasers. (349.173)
	4. The organization must pay in full or otherwise become the owner of all prizes prior to the raffle drawing, except for raffles with gross receipts of \$60 or less. (7861.0260)
	5. A merchandise certificate is used when a prize requiring registration or licensure (guns, cars, ATVs, etc.) is offered. (7861.0260)
	6. Prizes must not consist of lawful gambling equipment including raffle tickets for another raffle. (7861.0260)
	7. The total value of lawful gambling prizes awarded (use fair market value for donated prizes) does not exceed \$50,000 in a calendar year. (349.166)
	8. Cash must not be substituted for merchandise prizes that have been won. (7861.0260 Subp. 4C(2))
	9. Alcohol is only awarded as a prize to persons who demonstrate that they are 21 years of age or older. (340A.707)
	10. Only cash, personal checks, cashier’s checks, money orders, travelers’ checks, and debit cards may be accepted for the purchase of tickets (NO CREDIT CARDS – NO INTERNET SALES). (349.2127) (7861.0260)
	11. The method of winner selection cannot be manipulated or based on the outcome of an event not under the organization’s control. (349.173)
	12. Persons are not required to be present at a raffle drawing to be eligible to win. (349.173) (7861.0310)
	13. Raffle tickets are not sold to or won by persons under age 18. (349.181) (7861.0310)
	14. Purchasers are not required to buy anything other than the ticket. (349.173) (7861.0310)
	15. Clear and legible house rules in accordance with MN Rule 7861.0310 are prominently posted at the point of winner selection.
	16. An exempt permit financial report (LG220A) must be submitted to the Gambling Control Board within 30 days of the gambling occasion. (349.166)
BINGO	
	1. Clear and legible house rules in accordance with MN Rule 7861.0270 are prominently posted at the point of winner selection.
	2. House rules include the policy on declaring bingo and last number called. (7861.0270 Subp. 2A(1))
	3. House rules include the reasons for potentially cancelling bingo occasions. (7861.0270 Subp. 2A(1))
	4. All sales must be on a cash basis and take place at the permitted premises during or immediately prior to the bingo occasion. (NO CREDIT CARDS – NO INTERNET SALES) (7861.0270 Subp. 5B(1))
	5. Bingo paper must not be offered for free or discounted unless the price is reduced with a coupon. (7861.0270 Subp. 5B(7))
	6. Bingo balls must be available for inspection by at least one player before the occasion begins to determine that all are present and in operating condition. (7861.0270 Subp. 3A)
	7. No reservation of bingo cards or bingo paper for any person (7861.0270 Subp. 3F)
	8. Bingo records (including bingo program) must be kept for 3½ years. (7861.0270 Subp. 11)
BINGO AND RAFFLES	
	1. Gambling records must be kept for 3½ years. (7861.0310)
	2. Gambling funds may only be spent for allowable expenses and lawful purposes. (349.12 Subd. 3a) (349.12 Subd. 25) (mn.gov/gcb/faq-exemptexcluded.html) and (mn.gov/gcb/assets/infosheetspendinggamblingfunds.pdf)

2F. Consideration of approving an application for a temporary gambling permit for a raffle to be conducted by the Wright County Pheasants Forever, on March 21, 2026, at the Monticello Community Center

Prepared by: City Clerk	Meeting Date: 2/9/2026	<input checked="" type="checkbox"/> Consent Agenda Item <input type="checkbox"/> Regular Agenda Item
Reviewed by: N/A	Approved by: City Administrator	

ACTION REQUESTED

Motion to approve the application for a temporary gambling permit for the Wright County Pheasants Forever for raffle being held on March 21, 2026, at the Monticello Community Center.

REFERENCE AND BACKGROUND

The Wright County Pheasants Forever applied for a temporary charitable gambling permit for a raffle to be held on March 21, 2026. The event is being held at the Monticello Community Center.

To receive a permit from the State, the City must approve the application.

STAFF RECOMMENDED ACTION

City staff recommend approving the temporary gambling permit.

SUPPORTING DATA

- Application

MINNESOTA LAWFUL GAMBLING
LG220 Application for Exempt Permit

An exempt permit may be issued to a nonprofit organization that:

- conducts lawful gambling on five or fewer days, and
- awards less than \$50,000 in prizes during a calendar year.

If total raffle prize value for the calendar year will be \$1,500 or less, contact the Licensing Specialist assigned to your county by calling 651-539-1900.

Application Fee (non-refundable)

Applications are processed in the order received. If the application is postmarked or received 30 days or more before the event, the application fee is **\$100**; otherwise the fee is **\$150**.

Due to the high volume of exempt applications, payment of additional fees prior to 30 days before your event will not expedite service, nor are telephone requests for expedited service accepted.

ORGANIZATION INFORMATION

Organization Name: Wright County Pheasants Forever Previous Gambling Permit Number: X- 04218-26-021

Minnesota Tax ID Number, if any: 4874648 Federal Employer ID Number (FEIN), if any: 41-1429149

Mailing Address: 702 9th St NW

City: Buffalo State: MN Zip: 55313 County: Wright

Name of Chief Executive Officer (CEO): Eric Mattson

CEO Daytime Phone: 763-245-3961 CEO Email: matts288@gmail.com
(permit will be emailed to this email address unless otherwise indicated below)

Email permit to (if other than the CEO): eric.mattson@usda.gov

NONPROFIT STATUS

Type of Nonprofit Organization (check one):

- Fraternal Religious Veterans Other Nonprofit Organization

Attach a copy of one of the following showing proof of nonprofit status:

(DO NOT attach a sales tax exempt status or federal employer ID number, as they are not proof of nonprofit status.)

- A current calendar year Certificate of Good Standing**
Don't have a copy? Obtain this certificate from:
MN Secretary of State, Business Services Division Secretary of State website, phone numbers:
60 Empire Drive, Suite 100 www.sos.state.mn.us
St. Paul, MN 55103 651-296-2803, or toll free 1-877-551-6767
- IRS income tax exemption (501(c)) letter in your organization's name**
Don't have a copy? To obtain a copy of your federal income tax exempt letter, have an organization officer contact the IRS toll free at 1-877-829-5500.
- IRS - Affiliate of national, statewide, or international parent nonprofit organization (charter)**
If your organization falls under a parent organization, attach copies of both of the following:
1. IRS letter showing your parent organization is a nonprofit 501(c) organization with a group ruling; and
2. the charter or letter from your parent organization recognizing your organization as a subordinate.

GAMBLING PREMISES INFORMATION

Name of premises where the gambling event will be conducted (for raffles, list the site where the drawing will take place): Monticello Community Center

Physical Address (do not use P.O. box): 505 Walnut St., Monticello, MN 55362

Check one:
 City: Monticello Zip: 55362 County: Wright
 Township: _____ Zip: _____ County: _____

Date(s) of activity (for raffles, indicate the date of the drawing): March 21, 2026

Check each type of gambling activity that your organization will conduct:

- Bingo Paddlewheels Pull-Tabs Tipboards Raffle

Gambling equipment for bingo paper, bingo boards, raffle boards, paddlewheels, pull-tabs, and tipboards must be obtained from a distributor licensed by the Minnesota Gambling Control Board. EXCEPTION: Bingo hard cards and bingo ball selection devices may be borrowed from another organization authorized to conduct bingo. To find a licensed distributor, go to www.mn.gov/gcb and click on **Distributors** under the **List of Licensees** tab, or call 651-539-1900.

LG220 Application for Exempt Permit

LOCAL UNIT OF GOVERNMENT ACKNOWLEDGMENT (required before submitting application to the Minnesota Gambling Control Board)

**CITY APPROVAL
for a gambling premises
located within city limits**

The application is acknowledged with no waiting period.

The application is acknowledged with a 30-day waiting period, and allows the Board to issue a permit after 30 days (60 days for a 1st class city).

The application is denied.

Print City Name: _____

Signature of City Personnel: _____

Title: _____ Date: _____

The city or county must sign before submitting application to the Gambling Control Board.

**COUNTY APPROVAL
for a gambling premises
located in a township**

The application is acknowledged with no waiting period.

The application is acknowledged with a 30-day waiting period, and allows the Board to issue a permit after 30 days.

The application is denied.

Print County Name: _____

Signature of County Personnel: _____

Title: _____ Date: _____

TOWNSHIP (if required by the county)
On behalf of the township, I acknowledge that the organization is applying for exempted gambling activity within the township limits. (A township has no statutory authority to approve or deny an application, per Minn. Statutes, section 349.213.)

Print Township Name: _____

Signature of Township Officer: _____

Title: _____ Date: _____

CHIEF EXECUTIVE OFFICER'S SIGNATURE (required)

The information provided in this application is complete and accurate to the best of my knowledge. I acknowledge that the financial report will be completed and returned to the Board within 30 days of the event date.

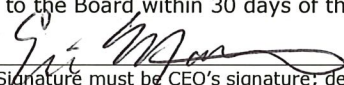
Chief Executive Officer's Signature:  Date: 1-22-26

(Signature must be CEO's signature; designee may not sign)

Print Name: Eric Mattson

REQUIREMENTS

Complete a separate application for:

- all gambling conducted on two or more consecutive days; or
- all gambling conducted on one day.

Only one application is required if one or more raffle drawings are conducted on the same day.

Financial report to be completed within 30 days after the gambling activity is done:
A financial report form will be mailed with your permit. Complete and return the financial report form to the Gambling Control Board.

Your organization must keep all exempt records and reports for 3-1/2 years (Minn. Statutes, section 349.166, subd. 2(f)).

MAIL APPLICATION AND ATTACHMENTS

Mail application with:

___ a copy of your proof of nonprofit status; and

___ application fee (non-refundable). If the application is postmarked or received 30 days or more before the event, the application fee is **\$100**; otherwise the fee is **\$150**. Make check payable to **State of Minnesota**.

To: Minnesota Gambling Control Board
1711 West County Road B, Suite 300 South
Roseville, MN 55113

Questions?
Call the Licensing Section of the Gambling Control Board at 651-539-1900.

Data privacy notice: The information requested on this form (and any attachments) will be used by the Gambling Control Board (Board) to determine your organization's qualifications to be involved in lawful gambling activities in Minnesota. Your organization has the right to refuse to supply the information; however, if your organization refuses to supply this information, the Board may not be able to determine your organization's qualifications and, as a consequence, may refuse to issue a permit. If your organization supplies the information requested, the Board will be able to process the application. Your organization's name and address will be public information when received by the Board. All other information provided will be private data about your organization until the Board issues the permit. When the Board issues the permit, all information provided will become public. If the Board does not issue a permit, all information provided remains private, with the exception of your organization's name and address which will remain public. Private data about your organization are available to Board members, Board staff whose work requires access to the information; Minnesota's Department of Public Safety; Attorney General; Commissioners of Administration, Minnesota Management & Budget, and Revenue; Legislative Auditor, national and international gambling regulatory agencies; anyone pursuant to court order; other individuals and agencies specifically authorized by state or federal law to have access to the information; individuals and agencies for which law or legal order authorizes a new use or sharing of information after this notice was given; and anyone with your written consent.

This form will be made available in alternative format (i.e. large print, braille) upon request.

2G. Consideration of authorizing Kids Haven Monticello Holdings, LLC as the signatory applicant to the proposed Jefferson Commons Fifth Addition Preliminary and Final Plat related to a 2.93-acre childcare facility development proposal on City-owned property while the purchase agreement is being finalized

<p>Prepared by: Economic Development Manager</p>	<p>Meeting Date: 2/9/2026</p>	<p><input checked="" type="checkbox"/> Consent Agenda Item <input type="checkbox"/> Regular Agenda Item</p>
<p>Reviewed by: Community Development Director, Finance Director, Community & Economic Development Coordinator</p>	<p>Approved by: City Administrator</p>	

ACTION REQUESTED

Motion to authorize Kids Haven of Monticello Holdings, LLC as the signatory applicant to the proposed Jefferson Commons Fifth Addition Preliminary and Final Plat and related land use actions for a 2.93-acre childcare facility development proposal on City-owned property while the purchase agreement is being finalized.

REFERENCE AND BACKGROUND

In late 2025, the City Council considered an offer from the owners of Kids Haven to purchase 2.93 acres of City-owned property along School Boulevard near the Emagine Monticello movie theater. Council directed staff to prepare a purchase agreement to facilitate the sale of the site for development of a childcare facility. The draft purchase agreement and related documents are currently under review by the buyer’s legal counsel prior to bringing a final version forward for consideration by the City Council.

In the meantime, a complete land use development application has been received from Kids Haven of Monticello Holdings, LLC for their proposed 26,704 square-foot childcare center. The application submittal included:

- Site Plans
- Preliminary Plat
- Final Plat draft
- Landscape Plan
- Architectural Plans
- Lighting Plans
- Access Easement Exhibit for L1 B1 and Outlot G

- Access Easement Exhibit for Outlot A
- Drainage Analysis
- Storm Sewer Pipe Size Analysis
- Title Commitment L1 B1 and Outlot G
- Title Commitment Outlot C

Typically, City policy requires that an entity proposing a land subdivision hold vested property rights, either through fee title interests or a purchase agreement. However, Kids Haven of Monticello Holdings, LLC remains in the process of obtaining those rights.

To allow the development review process to proceed, staff request that the City Council authorize Kids Haven of Monticello Holdings, LLC to act as the signatory applicant for the proposed Jefferson Commons Fifth Addition Preliminary and Final Plat and related land use entitlements.

The proposed childcare facility is an estimated \$5,850,000 +/- development on a parcel to be created through the subdivision of the City-owned 7.01-acre Outlot C, Jefferson Commons. The proposed subdivision also identifies a remaining City-owned development parcel of 4.01 acres, designated as Outlot A. Staff review of the submitted land use application is currently underway, and Planning Commission consideration of the Preliminary and Final Plat and related land use actions is targeted for the March 3, 2026, meeting.

A business subsidy public hearing will also be required as part of the land sale consideration.

- I. **Budget Impact:** The budget impact related to this item is minimal.
- II. **Staff Workload Impact:** The Community Development Director and Economic Development Manager have committed time to completing early-stage review of land use entitlement application material and preparation of the land sale purchase agreement. Additional City staff will dedicate further time to advancing both items.
- III. **Comprehensive Plan Impact:** The Economic Development section of the Comprehensive Plan encourages formation of an effective economic development effort which creates a supportive business environment and builds a vibrant, thriving local economy.

STAFF RECOMMENDATION

Staff recommend authorizing Kids Haven of Monticello Holdings, LLC as the signatory applicant to the proposed Jefferson Commons Fifth Addition Preliminary and Final Plat and related land use considerations while the purchase agreement is being finalized.

SUPPORTING DATA

- A. Preliminary Plat
- B. Final Plat

SITE PLAN NOTES

- ALL DIMENSIONS SHOWN ARE TO FACE OF CURB OR EDGE OF PAVEMENT UNLESS OTHERWISE NOTED.
- MATCH EXISTING GRADES AT EXISTING PAVEMENT TO REMAIN.
- EXISTING PAVEMENT TO REMAIN SHALL BE SAW CUT FOR CLEAN EDGE. TACK SHALL BE USED ON ALL VERTICAL EDGES PRIOR TO PATCHING.
- CONTRACTOR SHALL VERIFY AND COORDINATE CONDUIT REQUIREMENTS FOR UNDERGROUND UTILITIES IF ANY WITHIN THE WORK ZONE WITH THE OWNER PRIOR TO PAVING.
- CONTRACTOR IS RESPONSIBLE FOR COORDINATING WITH FIRE MARSHALL FOR POSTING OF FIRE LANES, CURB MARKING AND SIGNAGE AS REQUIRED.
- CONTRACTOR IS RESPONSIBLE FOR DEMOLITION AND REMOVAL OF ALL EXISTING SITE FEATURES THAT INTERFERE WITH NEW WORK AS SHOWN.

SETBACKS:

LOCATION:	BUILDING
FRONT	30'
INTERIOR SIDE YARD	10'
REAR YARD	20'
STREET SIDE	20'

LOT MINIMUM:

Base Lot Area	No Minimum
Base Lot Width	100 ft Minimum

PARKING DATA

REQUIRED PARKING
 1.0 SPACE FOR EACH EMPLOYEE PLUS ONE SPACE PER FIVE CHILDREN
 316 STUDENTS
 35 STAFF MAX SHIFT
 TOTAL REQUIRED STALLS = 99

PROVIDED PARKING
 85 STALLS (INCLUDES 4 HANDICAP STALLS)
 14 PROOF PARKING STALLS

EXISTING DESCRIPTION

OUTLOT C, JEFFERSON COMMONS EXCEPT THAT PART PLATED AS JEFFERSON COMMONS SECOND ADDITION, WRIGHT COUNTY, MINNESOTA.

PROJECT LOCATION

NE 1/4 of the SE 1/4 SECTION 15 TOWNSHIP 121, RANGE 25, WRIGHT COUNTY, MINNESOTA.

SURVEY DATA

SURVEY INFORMATION PROVIDED BY:
 MEYER ROHLIN LAND SERVICES
 708 1st AVENUE NE
 BUFFALO, MN 55313

DATED: DECEMBER 10, 2025

BENCHMARK NO. 2:
 TOP NUT HYDRANT
 ELEV.=964.89

SITE DATA:

EXISTING ZONING: B-3 BUSINESS DISTRICT
 TOTAL AREA OUTLOT C: 305,756 SF = 7.02 ACRES
 TOTAL AREA LOT 1: 127,517 SF = 2.93 ACRES
 PROPOSED BUILDING AREA: 26,704 SF
 FLOOR AREA RATIO (ALL FLOORS): 0.209 (26,704 / 127,517)
 EXISTING IMPERVIOUS AREA LOT 1: 4,651 SF (Includes existing pavement area)
 ADDITIONAL PROPOSED IMPERVIOUS LOT 1 AREA: 73,297 SF (building and pavement areas)
 EXISTING IMPERVIOUS AREA: 4,651 SF (Includes existing pavement areas)

TOTAL IMPERVIOUS AREA: 77,948 SF
 PERCENT PROPOSED IMPERVIOUS AREA: 61.13% (% of lot area: 77,948/127,517)
 TOTAL PERVIOUS AREA: 49,569 SF (landscape, turf areas)
 PERCENT PERVIOUS AREA: 38.87% (% of lot area: 49,569/127,517)
 DISTURBANCE AREA: 38,535 SF
 3.26 AC

LEGEND:

- EXISTING BOUNDARY
- EXISTING EASEMENT
- EXISTING SETBACK
- EXISTING R/W LINE
- CONCRETE LIGHT DUTY
- CONCRETE HEAVY DUTY
- BITUMINOUS PAVEMENT
- AGGREGATE SURFACE
- PROPOSED R/W OR LOT LINE
- PROPOSED CURB AND GUTTER STANDARD
- PROPOSED CURB AND GUTTER TIP-OUT
- PROPOSED PARKING STALLS
- PROPOSED PROOF PARKING STALLS

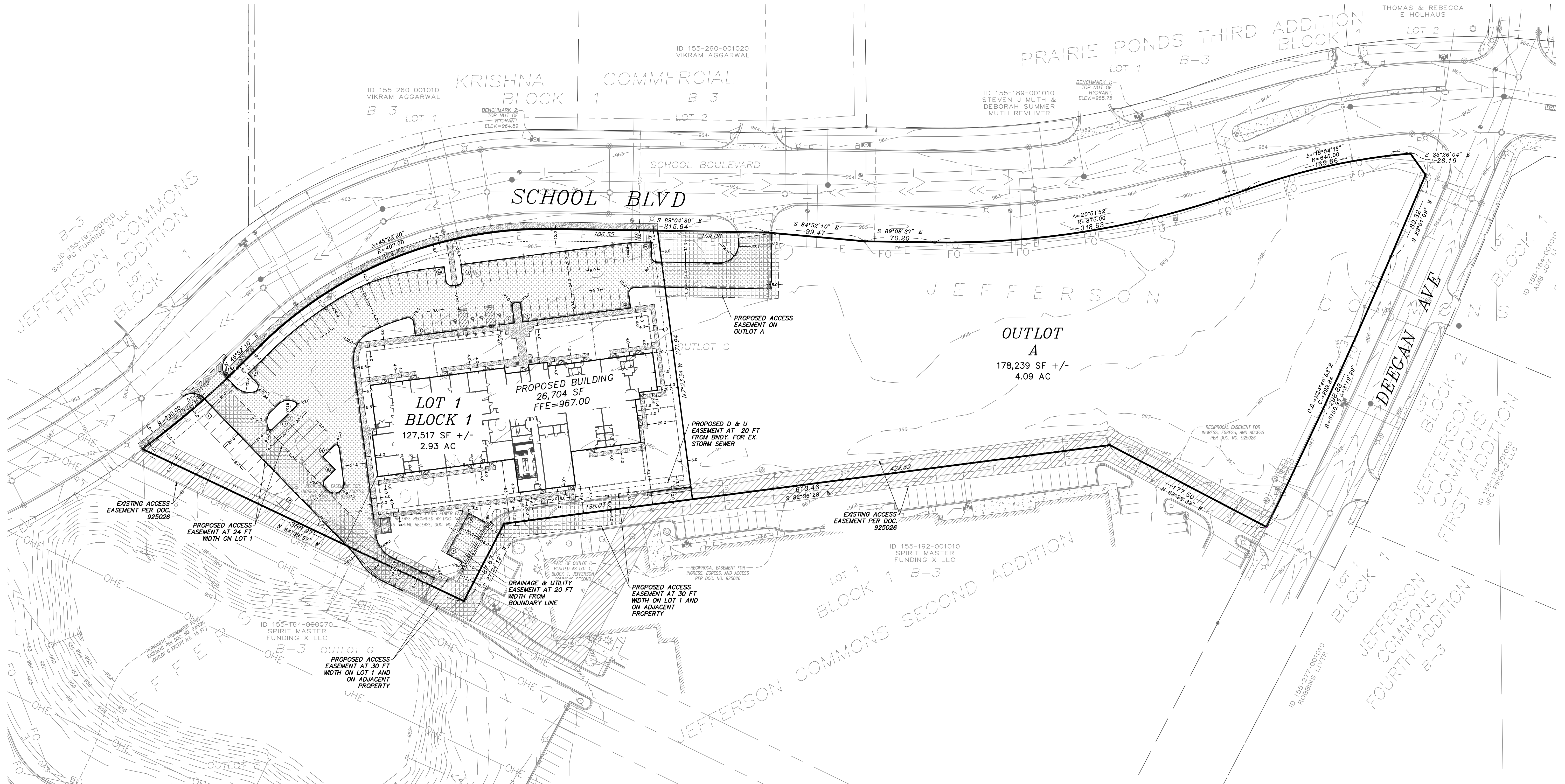
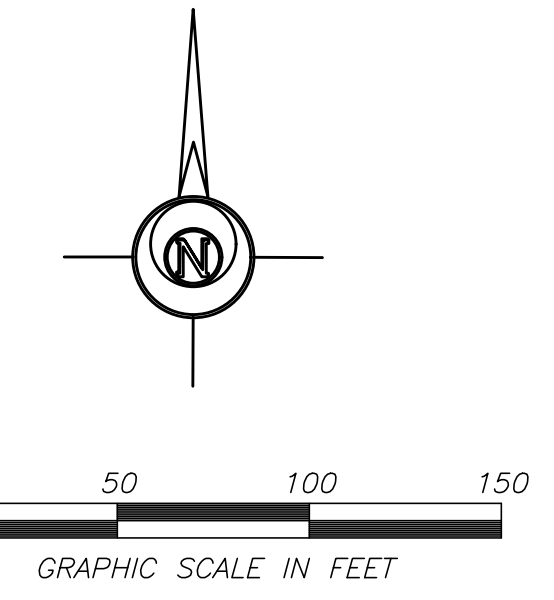

CLIENT:
KID'S HAVEN CHILD CARE AND PRESCHOOL
 302 12th Ave S
 Buffalo, MN 55313
 Missy Sjolin
 msjolin@kidshaven.net
 763-682-3072

PRELIMINARY PLAT OF JEFFERSON COMMONS FIFTH ADDITION
 xxxxxx School Blvd
 Monticello, MN 55962
 PRELIMINARY PLAT

I hereby certify that this plan, specification, or report was prepared by me or under my direct supervision and that I am a duly Licensed Professional Engineer under the laws of the State of Minnesota.
 Date: 02/02/26 Reg. No. 24348
 PREPARED BY: CIVIL ENGINEERING SITE DESIGN
 118 East Broadway St.
 Monticello, MN 55362
 Phone: 763-314-0929
 www.civildesign.com

DATE	BY
02/02/26	SD
DRAWN BY	SD
DESIGNED BY	SD
CHECKED BY	SD

FILE NO. 00992
 1/1
 Preliminary Plat

JEFFERSON COMMONS FIFTH ADDITION

PRELIMINARY DRAFT FOR CITY REVIEW - REVISED 01/30/2026

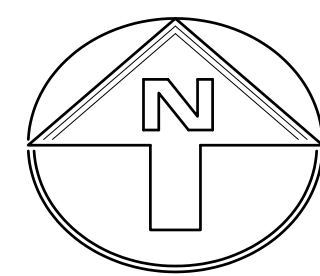

GRAPHIC SCALE IN FEET
1 INCH = 60 FEET (IF PRINTED FULL SIZE)

- DENOTES IRON MONUMENT FOUND
- DENOTES 1/2 in. x 14 in. IRON MONUMENT SET, MARKED BY LICENSE NO. 48664
- ▲ DENOTES P.K. NAIL FOUND
- △ DENOTES P.K. NAIL SET
- ◎ DENOTES WRIGHT COUNTY MONUMENT FOUND

BEARING ORIENTATION:
THE EAST LINE OF THE SOUTHEAST 1/4 OF SECTION 15, T. 121, R. 25 IS ASSUMED TO BEAR S 00°47'55" E.

Drainage and utility easements are shown thus:

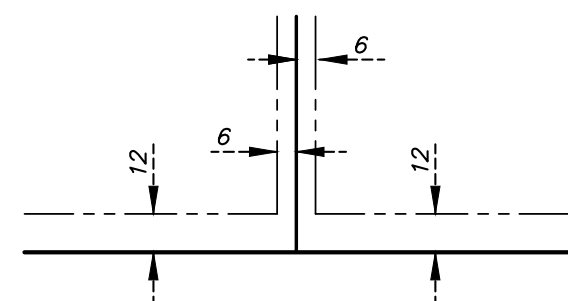

Being 6.00 feet in width, unless otherwise indicated, and adjoining lot lines, and 12.00 feet in width, adjoining right-of-way lines as shown on this sheet of the plat.

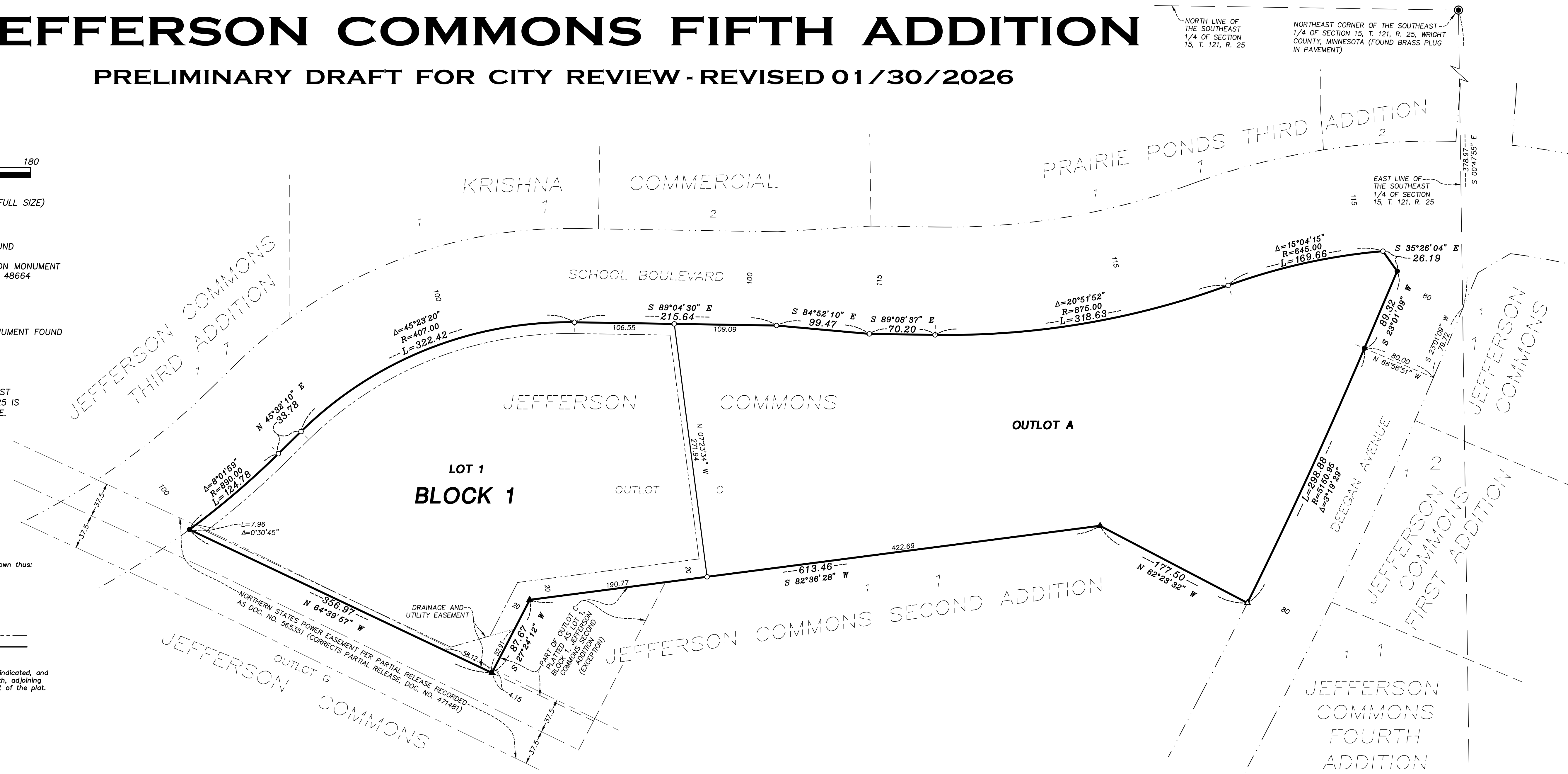

KNOW ALL PERSONS BY THESE PRESENTS: That City of Monticello, a Minnesota Municipal Corporation under the laws of the State of Minnesota, owner of the following described property situated in the County of Wright, State of Minnesota, to wit:

Outlot C, JEFFERSON COMMONS, except that part platted as JEFFERSON COMMONS SECOND ADDITION, Wright County, Minnesota.

Has caused the same to be surveyed and platted as JEFFERSON COMMONS FIFTH ADDITION and does hereby dedicate to the public for public use the drainage and utility easements as created by this plat.

In witness whereof said City of Monticello, a Minnesota Municipal Corporation under the laws of the State of Minnesota, has caused these presents to be signed by its proper officer this ____ day of _____, 20____.

City of Monticello

Mayor

City Administrator

STATE OF MINNESOTA
COUNTY OF _____

This instrument was acknowledged before me this ____ day of _____, 20____, by _____, Mayor and _____, City Administrator of City of Monticello, a Minnesota Municipal Corporation under the laws of the State of Minnesota, on behalf of the corporation.

(Signature)

(Name Printed)

Notary Public, _____ County, Minnesota

My Commission Expires _____

I, Abram A. Niemela, do hereby certify that this plat was prepared by me or under my direct supervision; that I am a duly Licensed Land Surveyor in the State of Minnesota; that this plat is a correct representation of the boundary survey; that all mathematical data and labels are correctly designated on this plat; that all monuments depicted on this plat have been, or will be correctly set within one year; that all water boundaries and wet lands, as defined in Minnesota Statutes, Section 505.01, Subd. 3, as of the date of this certificate are shown and labeled on this plat; and all public ways are shown and labeled on this plat.

Dated this ____ day of _____, 20____.

Abram A. Niemela, Licensed Land Surveyor
Minnesota License No. 48664

STATE OF MINNESOTA
COUNTY OF WRIGHT

The foregoing Surveyor's Certificate was acknowledged before me this ____ day of _____, 20____, by Abram A. Niemela, Licensed Land Surveyor, Minnesota License No. 48664.

(Signature)

(Name Printed)

Notary Public, _____ County, Minnesota

My Commission Expires _____

CITY OF MONTICELLO PLANNING COMMISSION

Be it known that at a meeting held on this ____ day of _____, 20____, the Planning Commission of the City of Monticello, Minnesota, did hereby review and approve this plat of JEFFERSON COMMONS FIFTH ADDITION.

Chairperson

Secretary

CITY COUNCIL, CITY OF MONTICELLO, MINNESOTA

This plat of JEFFERSON COMMONS FIFTH ADDITION was approved and accepted by the City Council of the City of Monticello, Minnesota, at a regular meeting thereof held this ____ day of _____, 20____, and said plat is in compliance with the provisions of Minnesota Statutes, Section 505.03, Subd. 2.

Mayor

City Clerk

WRIGHT COUNTY SURVEYOR

I hereby certify that in accordance with Minnesota Statutes, Section 505.021, Subd. 11, this plat has been reviewed and approved this ____ day of _____, 20____.

Wright County Surveyor

WRIGHT COUNTY LAND RECORDS

Pursuant to Minnesota Statutes, Section 505.021, Subd. 9, taxes payable for the year 20____ on the land hereinbefore described have been paid. Also, pursuant to Minnesota Statutes, Section 272.12, there are no delinquent taxes and transfer entered this ____ day of _____, 20____.

Wright County Land Records Administrator

WRIGHT COUNTY RECORDER

I hereby certify that this instrument was filed in the office of the County Recorder for record on this ____ day of _____, 20____ at ____ o'clock ____ M., and was duly recorded in Cabinet No. _____, Sleeve _____, as Document No. _____.

Wright County Recorder

VICINITY MAP

SECTION 15, T. 121, R. 25, WRIGHT COUNTY, MN
(NO SCALE)

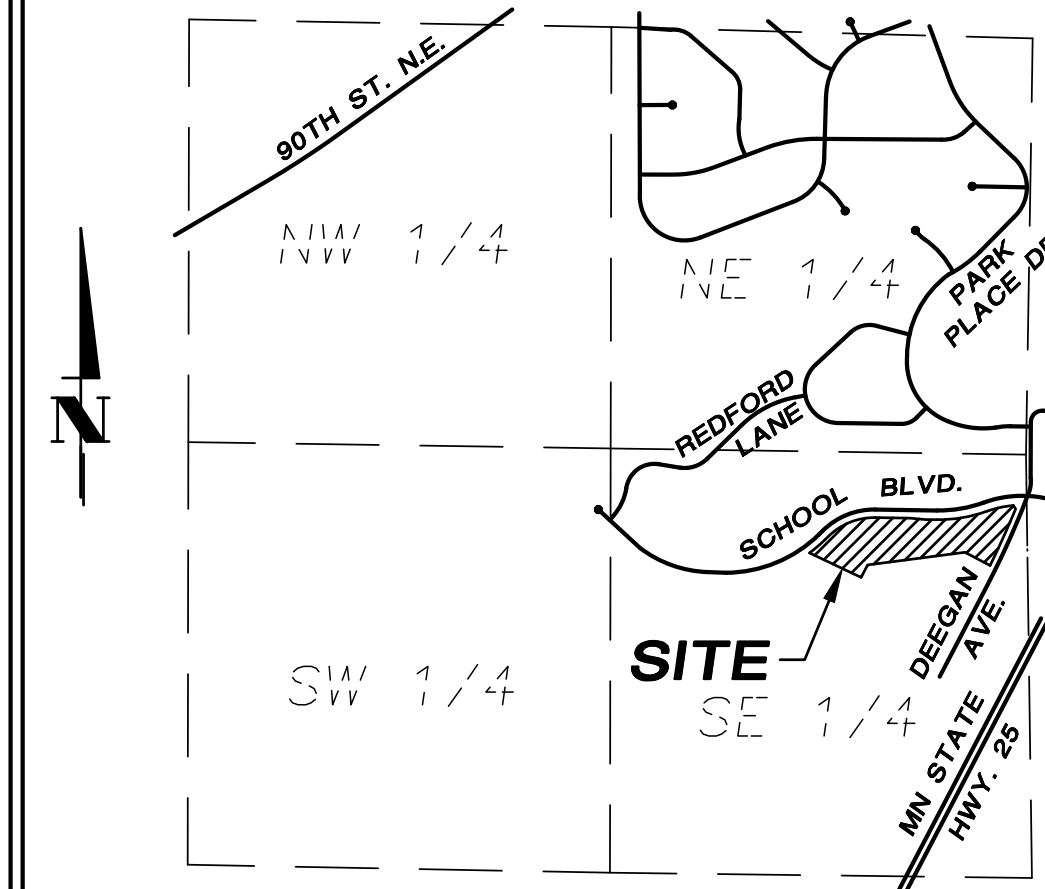

2H. Consideration of approving final 2025 Operating Transfers

Prepared by: Finance Director	Meeting Date: 2/9/2026	<input checked="" type="checkbox"/> Consent Agenda Item <input type="checkbox"/> Regular Agenda Item
Reviewed by: N/A	Approved by: City Administrator	

ACTION REQUESTED

Motion to approve the final 2025 Operating Transfers.

REFERENCE AND BACKGROUND

Operating transfers shift money from one fund to another. This is done for a variety of reasons, including to:

- repay debt
- cover unanticipated operating expenditures
- close city funds that are no longer needed or open new funds
- finance city projects

The transfers listed as items a – e were anticipated and authorized when the council adopted the 2025 budget resolution 2024-127. However, some items were approved at estimated amounts and staff request to adjust the approved transfers as needed. Transfer e) is a shift in Council strategy by allowing net profits from the liquor store to build up in that fund until a specific project is identified for use of that funding rather than transferring available funding to the Capital Projects Fund annually.

Transfer f) reflects the closure of the Park & Pathway Improvement Fund into the Capital Projects Fund. Capital projects for recreational activities have historically been paid for out of the Park & Pathway Improvement Fund with funding from grants and/or transfers from the Capital Project Fund’s tax levy or reserves. To streamline recording of these projects, staff recommend closing the Park & Pathway Improvement Fund and using the Capital Projects Fund instead, which is how most non-recreational capital projects are accounted for. The city’s Park Dedication Fund, which is funded by contributions from developers restricted to new recreational improvements, still remains a separate funding mechanism for eligible capital projects.

Transfer g) from the General Fund to the Capital Projects Fund reflects a funding strategy to match favorable budget-to-actual results, which are non-recurring in nature, to non-recurring expenditures in the Capital Projects Fund.

The proposed final 2025 operating transfers are as follows:

	Transfer From	Transfer To	Budgeted Amount	Added or Rescinded	Final Transfer
* a.	101 - General	213 - EDA	\$ 6,000	\$ (2,340)	\$ 3,660
* b.	653 - Deputy Registrar	226 - Community Center	100,000	-	100,000
* c.	653 - Deputy Registrar	404 - Park & Pathway Improvement	402,000	-	402,000
* d.	403 - Street Lighting Improvement	400 - Capital Projects	380,000	-	380,000
* e.	609 - Liquor	400 - Capital Projects	500,000	(500,000)	-
f.	404 - Park & Pathway Improvement	400 - Capital Projects	-	702,951	702,951
g.	101 - General	400 - Capital Projects	-	250,000	250,000

**Included in Resolution 2024-127 adopting the 2025 budget.*

Description:

- a. Budgeted - Transfer to reimburse EDA for stipends paid to board members.
Amended to reflect actual amount of stipends paid.
- b. Budgeted - Transfer to provide funding support to Community Center operations.
- c. Budgeted - Transfer to provide funding support for new West Bridge Park playground structure.
- d. Budgeted - Transfer to provide funding for School Boulevard Transportation Improvement Project lighting.
- e. Budgeted - Transfer to allocate available fund reserves to future project costs.
Amended to retain liquor store funding in the Liquor Fund until transferring out for a specific future project.
- f. Transfer to close the Park & Pathway Improvement Fund into the Capital Projects fund due to lack of a dedicated, ongoing funding source outside of operating transfers.
- g. Transfer to allocate one-time available fund reserves to one-time future project costs.

I. Budget Impact: Varies by fund as noted above.

II. Staff Impact: N/A

III. Comprehensive Plan Impact: N/A

STAFF RECOMMENDED ACTION

City staff recommend approving the final 2025 Operating Transfers.

SUPPORTING DATA

- Resolution 2024-127 adopting the 2025 Budget and Authorizing Certain Finance-Related Actions

**CITY OF MONTICELLO
WRIGHT COUNTY, MINNESOTA
RESOLUTION NO. 2024-127**

**ADOPTING THE 2025 BUDGET, TRANSFERS AND OTHER
BUDGET-RELATED AUTHORIZATIONS**

WHEREAS, the budget is the fiscal blue print for the entire year where the City Council has considered and incorporated all foreseeable spending plans for 2025; and

WHEREAS, the City, through sound fiscal policy, establishes that current revenues will be used to finance current expenditures and regularly occurring capital expenditures; and

WHEREAS, the City Council shall by this resolution set forth the total expenditures and uses, excluding depreciation, and the total revenues and other sources for each budgeted fund.

NOW THEREFORE, BE IT RESOLVED, by the City Council of the City of Monticello the following is hereby approved:

**SECTION 1. AUTHORIZATION OF ESTIMATED REVENUES FROM ALL SOURCES,
APPROPRIATIONS, AND FUND BALANCE ADDED (EXPENDED):**

Fund	2025 Budgeted Revenues	2025 Budgeted Expenditures	Fund Balance Added (Expended)
General Fund	\$ 13,181,000	\$ 13,181,000	\$ -
Special Revenue Funds			
Cemetery	\$ 52,000	\$ 36,000	\$ 16,000
Small Community Development Grant	27,000	-	27,000
Monticello Community Center	2,067,000	2,067,000	-
Total Special Revenue Funds	\$ 2,146,000	\$ 2,103,000	\$ 43,000
Debt Service Funds			
2015B G.O. Bonds	\$ 184,000	\$ 214,000	\$ (30,000)
2016A G.O. Bonds	502,000	529,000	(27,000)
2017A G.O. Bonds	441,000	472,000	(31,000)
2018A G.O. Bonds	422,000	448,000	(26,000)
2019A G.O. Bonds	696,000	714,000	(18,000)
2020A G.O. Bonds	204,000	235,000	(31,000)
Total Debt Service Funds	\$ 2,449,000	\$ 2,612,000	\$ (163,000)
Capital Project Funds			
Capital Project	\$ 4,667,000	\$ 5,787,000	\$ (1,120,000)
Street Lighting Improvement	160,000	380,000	(220,000)
Park & Pathway Improvement	687,000	916,000	(229,000)
Park Dedication	6,000	-	6,000
BCOL Sales Tax	1,000,000	215,000	785,000
Total Capital Project Funds	\$ 6,520,000	\$ 7,298,000	\$ (778,000)
Enterprise Funds			
Water	\$ 2,084,000	\$ 3,372,000	\$ (1,288,000)
Sewer	4,595,000	7,902,000	(3,307,000)
Stormwater	2,203,000	3,156,000	(953,000)
Liquor	7,441,000	7,166,000	275,000
Deputy Registrar	1,134,000	1,312,000	(178,000)
Fiber Optics	1,948,000	1,981,000	(33,000)
Total Enterprise Funds	\$ 19,405,000	\$ 24,889,000	\$ (5,484,000)
Internal Service Funds			
Facilities Maintenance	\$ 700,000	\$ 700,000	\$ -
IT Services	594,000	594,000	-
Central Equipment	665,000	645,000	20,000
Benefit Accrual	15,000	15,000	-
Total Internal Service Funds	\$ 1,974,000	\$ 1,954,000	\$ 20,000
Component Units			
Economic Development Authority	\$ 896,000	\$ 757,000	\$ 139,000
Total Component Units	\$ 896,000	\$ 757,000	\$ 139,000
Total All Funds	\$ 46,571,000	\$ 52,794,000	\$ (6,223,000)

SECTION 2. TRANSFERS:

By resolution, the Council can amend or rescind transfers in this section as the year progresses. The following list may include transfers for projects that have not received formal council authorization.

- a. To EDA Fund from General Fund - \$6,000
- b. To Capital Projects Fund from Liquor Fund - \$500,000
- c. To Capital Projects Fund from Street Lighting Improvement Fund - \$380,000
- d. To Community Center Fund from Deputy Registrar Fund - \$100,000
- e. To Parks & Pathway Improvement Fund from Deputy Registrar Fund - \$402,000

SECTION 3. OTHER BUDGET-RELATED AUTHORIZATIONS:

- a. Removes prior commitments and assignments, except those required by GASB, from fund balance classifications.
- b. Sets the General Fund reserve policy at 60-75% of expenditures.
- c. Approves Senior Center annual subsidy of \$70,000.
- d. Approves a 3.5% wage adjustment to full-time employees (Pay Grades U9-U11, H100-H260, and S100-S260), part-time Community Center employees (Pay Grades M01-M06), other part-time and temporary employees (Pay Grades T01-T04), and paid on call firefighters commencing on first pay period beginning in January 2025.
- e. Sets the monthly fire department officer stipends at \$700 for Fire Chief, \$465 for Assistant Fire Chief, \$275 for Fire Captains, \$225 for Public Relations, and \$320 for the Fire Secretary. *(Corrected on January 13, 2025)*
- f. Establishes the monthly standard health insurance benefits for union employees with an effective date of March 1, 2025 at \$1,326.08 for family coverage (single coverage fully paid by City at \$1,565). The monthly standard health benefits for participating non-union employees are \$988.54 for the single plan and \$1,959.67 for the family plan. Premium contributions are required from family/dependent plan participants for the difference between the standard benefit and coverage costs. No contribution is required from single-plan and non-plan participants.

ADOPTED BY the Monticello City Council this 9th day of December, 2024.

CITY OF MONTICELLO

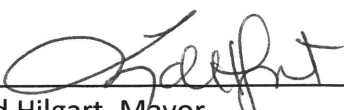

Lloyd Hilgart, Mayor

ATTEST:



Jennifer Schreiber, City Clerk

2I. Consideration of approving a special event permit for MontiArts Glow Fest 2026 on February 28, 2026. Applicant: MontiArts

<p>Prepared by: Parks & Recreation Director</p>	<p>Meeting Date: 2/9/2026</p>	<p><input checked="" type="checkbox"/> Consent Agenda Item <input type="checkbox"/> Regular Agenda Item</p>
<p>Reviewed by: City Clerk</p>	<p>Approved by: City Administrator</p>	

ACTION REQUESTED

Motion to approve a Special Event Permit for the MontiArts Glow Fest 2026, including a walking street closure, on February 28, 2026.

REFERENCE AND BACKGROUND

Now in its seventh year, the MontiArts Glow Fest has grown from a small gathering into a highly anticipated annual event. The initial event included community members creating handmade lanterns and a small parade; over the years it has evolved into a citywide celebration of light, art, and community.

Each year, the festival expands with lantern-building workshops, food trucks, and increased participation from businesses and community organizations. The event welcomes all ages, featuring a glowing, community-led parade, interactive art installations, live performances, and gathering spaces with bonfires, music, and refreshments.

Glow Fest 2026 will take place on February 28, 2026, from 6:00 to 9:00 p.m. at the Monticello Community Center (MCC) and West Bridge Park. Participants will parade from the MCC down Walnut Street to West Bridge Park with handmade lanterns, glowing sculptures and illuminated outfits. Pedestrian safety will be supported by 6-8 scout volunteers assisting with street crossings, Wright County Sheriff reserves following the parade, and a deputy stationed at Broadway.

At West Bridge Park, attendees will enjoy a Glow DJ, projection artists, a mini donut food truck, hot chocolate, s'mores, and a staffed campfire.

- I. **Budget Impact:** MontiArts received a non-match Project Grant from the Central Minnesota Arts Board (CMAB) for this event.
- II. **Staff Workload Impact:** Staff involvement includes MCC staff, MontiArts staff, and Parks staff assisting with setup and takedown at the park.

- III. Comprehensive Plan Impact:** The Monticello 2040 Plan emphasizes the importance of art programming and community events.

STAFF RECOMMENDED ACTION

City staff recommend approving the special event permit and the walking street closure.

SUPPORTING DATA

- A. Application
- B. Event Map



CITY OF MONTICELLO
 City Clerk
 505 Walnut Street, Suite 1
 Monticello, MN 55362
 (763) 295-2711 info@MonticelloMN.gov

Temporary & Special Event Permit Application

APPLICATIONS WILL BE PROCESSED AFTER ALL ITEMS ARE SUBMITTED

Applications must be submitted no less than 15 working days prior to an Event, unless otherwise approved by City Clerk. Applicants are advised to discuss their request with City Clerk as early as possible to ensure the event can be approved on the date desired.

Date(s) of & Times of Event	Saturday, February 28th, 6-9pm
Nature or Purpose of Event	Community Event
Address of Event	MCC, Walnut Street Parade & West Bridge Park
Legal Description or PID	

Organization	MontiArts (parks, Arts and Recreation)
Applicant Name	Erica Witzmann
Applicant Address	5050 Walnut Street
Contact Phone Number	763-295-2711
Property Owner	Monticello Community Center and West Bridge Park
Address	505 Walnut Street & 107 W River Street
Contact Phone No	

The review and consideration of an application submitted shall occur with a written description of event including items checked below, an aerial map of location and layout of event.

All items checked below are required in support of the application and is deemed complete by the City Clerk's Office.

Check Items that Apply	
X	Use of City Park West Bridge Park
X	Use of Monticello Community Center Space Gym
	Alcohol consumption.
X	Street closure Temporary closure of Broadway by Sheriffs Department
X	Event times/dates including set-up & tear-down times. 10am-9:30PM
X	Lighting. Temporary reducing park lights at West Bridge

X	Music, including bands, amplification, speakers and other possible noise. DJ at Park
	Parking.
X	Security. One Sherriff confirmed- 2 reservists requested
X	Signage.
X	Solid waste disposal (port-a-potties).
	Tent – Number and size.
	Attach a neighborhood flyer or door tag alerting residents which will be affected by event.
	Other items as requested by City Clerk.

Site plan or survey of property showing the following.

- Building and location of the event.
- Parking.
- Exact location of tents, displays related to events& activities, stages, security, lighting, food/drink areas
- Street closure

PROPERTY INFORMATION

APPLICANT CHECK	APPLICATION SUBMITTAL REQUIREMENTS	CITY CHECK-IN
	Application fee: \$50 \$25 – for non-profit/charitable organization	

IF REQUESTING A WAIVER OF FEES, APPLICANTS MUST SUBMIT A PROPOSAL FOR AN ADDITIONAL COMMUNITY SERVICE PROJECT BENEFITTING THE PARKS, ARTS, & RECREATION DEPARTMENT OR THE CITY. THE PROPOSAL MUST BE APPROVED BY THE CITY CLERK.

SIGNATURE OF APPLICANT AND PROPERTY OWNER REQUIRED

By signing below, the applicant/property owner for the submitted event being held on the property named in this application agree(s) to defend, indemnify, and hold harmless the City of Monticello, Minnesota, its employees, agents, representatives, elected city officials, appointed city officials, and city council members from and against any claims, demands, suits, losses, costs, expenses (including attorney fees), or any other type of damages which may be asserted, claimed, sought, awarded, or recovered against or from the City of Monticello, Minnesota, its employees agents, representatives, elected city officials, appointed city officials, and city council members, as a result of the event by reason of any damage to the property, personal injury or bodily injury including death, sustained by any person whomsoever in which such damage, injury or death arises out of, is incidental to, or is in any way connected whatsoever with the performance of this contract, the temporary special event referenced herein, or anything connected thereto, and regardless of whether the claim, demand, damage, loss, cost, or expense is caused in whole or in part, by the event organizer and/or promoter, or any of its employees, agents, representative, the negligence of the City of Monticello, Minnesota, its employees, agents, representatives, elected city officials, appointed city officials, or city council members, or by any third parties or their agents, servants or employees.

Applicant's Signature: Erica Witzmann- Director MC

Date: 12/19/25

Property Owner's Signature:
(If different than applicant)

Date:

Office Use Only	
(City Clerk Signature)	(Date)

Notes: Monticello Glow Fest 2026
Now in its 7th year, the MontiArts Glow Fest has grown from a small gathering of community members into one of the city's most anticipated annual events. What began with a handful of people creating handmade lanterns in the MontiArts garage has flourished into a vibrant, city-wide celebration of light, art, and community. Each year, the festival expands, incorporating lantern-building workshops, local food trucks, and increased involvement from businesses and community organizations. The event brings together people of all ages to participate in a magical evening of creativity and connection, featuring a glowing community led parade, interactive art installations, live performances, and warm gathering spaces with bonfires, music, and refreshments.
The continued success of the MontiArts Glow Fest reflects MontiArts's commitment to fostering public art, community connection, and community engagement. As the event grows, it not only strengthens local partnerships but also enhances the city's

MontiArts

GET READY TO GLOW!

MontiArts GlowFest 2026
Saturday, February 28th
6-9PM



GlowFest is a free, family-friendly winter celebration of art, light, and community. The evening begins at the Monticello Community Center, where participants gather before joining a lantern-lit parade down Walnut Street to West Bridge Park.

Community members are welcome to carry large sculptural lanterns and smaller community-made glowing lanterns in the parade, or bring their own creations. At the park, enjoy an evening of winter fun with a DJ, fire dance performances, projection art, bonfires, food, and activities for all ages. Come as you are, or light up the night with your own handmade creations.

GLOWFEST PARADE MAP 2026

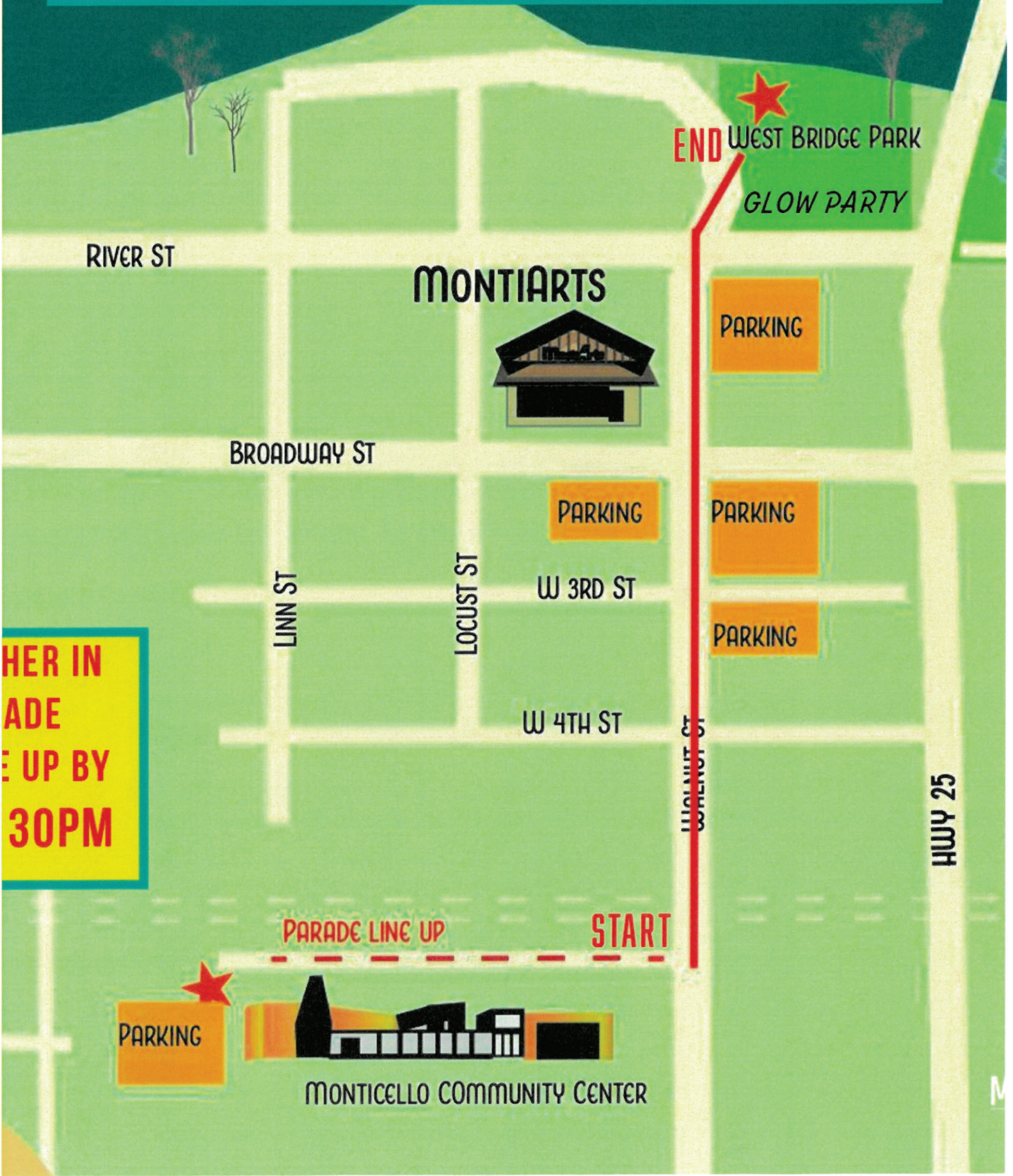

GLOWFEST PARADE MAP 2026

END WEST BRIDGE PARK
GLOW PARTY

RIVER ST

MONTIARTS

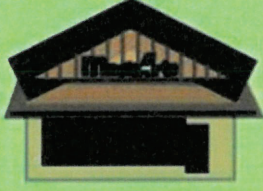

PARKING

BROADWAY ST

PARKING

PARKING

LINN ST

LOCUST ST

W 3RD ST

PARKING

HER IN
PARADE
LINE UP BY
30PM

W 4TH ST

WALNUT ST

HWY 25

PARADE LINE UP **START**

★
PARKING



MONTICELLO COMMUNITY CENTER

2J. Consideration of approving a Special Event Permit authorizing the Parks, Arts & Recreation Department, in partnership with the Swim Bait Club to host a fishing tournament and expo, including the use of the MCC Warehouse on February 21, 2026

Prepared by: Parks & Recreation Director	Meeting Date: 2/9/2026	<input checked="" type="checkbox"/> Consent Agenda Item <input type="checkbox"/> Regular Agenda Item
Reviewed by: City Clerk	Approved by: City Administrator	

ACTION REQUESTED

Motion to approve a Special Event Permit authorizing the Parks, Arts & Recreation Department to partner with the Swim Bait Club (FYBO) to host a fishing tournament and expo, including the use of the Monticello Community Center Warehouse on February 21, 2026.

REFERENCE AND BACKGROUND

The City of Monticello continues to highlight the Mississippi River as a key community asset. The proposed partnership with the Swim Bait Club creates a safe, environmentally responsible winter event that draws residents, visitors, and outdoor enthusiasts to the riverfront.

The free Freeze Your Bass Off Tournament attracts anglers from across central Minnesota and beyond. Monticello’s riverfront access positions the city as a destination for high-quality, shore-based fishing, supporting local businesses and reinforcing its identity as a hub for outdoor recreation.

Additional sponsors enhance the tournament experience, while the City offers in-kind contributions of Warehouse and expo space, staff support, and promotion to help keep the event free and community focused.

The day begins with a 7:30 a.m. angler meeting at the Monticello Community Center Warehouse followed by shoreline fishing using public access points. Anglers return by 3:00 p.m. to submit videos of their catches, with prizes and awards presented from 3:00 – 4:00 p.m.

- I. **Budget Impact:** The Warehouse rental rate is \$60/hour. The Warehouse is generally available for rentals after 9:00 a.m. on Saturdays. For the requested time of 7:00 a.m. - 4:00 p.m., the total rental cost would be \$420. The fitness class will be relocated to half of the gymnasium, ensuring that the class schedule and MCC members are not impacted.
- II. **Staff Workload Impact:** Staff will support event logistics, facility access, and coordination with the Swim Bait Club and MNDNR.

III. Comprehensive Plan Impact: Supports riverfront activation, community recreation, local business engagement, and tourism development.

STAFF RECOMMENDED ACTION

City staff recommend approving the Special Event Permit authorizing the Parks, Arts & Recreation Department to partner with the Swim Bait Club (FYBO) to host a fishing tournament and expo, including the use of the City MCC warehouse on February 21, 2026.

SUPPORTING DATA

- Application



CITY OF MONTICELLO
City Clerk
 505 Walnut Street, Suite 1
 Monticello, MN 55362
 (763) 295-2711
info@MonticelloMN.gov

Special Event Permit Application

(For events over 100 people and/or requesting use of City resources)

APPLICATIONS WILL BE PROCESSED AFTER ALL ITEMS ARE SUBMITTED

Applications must be submitted no less than 15 working days prior to an Event, unless otherwise approved by City Clerk. Applicants are advised to discuss their request with City Clerk as early as possible to ensure the event can be approved on the date desired.

Date(s) of & Times of Event	Saturday, Feb. 21, 7am-3pm
Nature or Purpose of Event	Fishing Tournament
Address of Event	Mississippi River Banks in Monticello
Legal Description or PID	

Organization	Freeze Your Bass Off and Monticello Community Center
Applicant Name	Sara Cahill
Applicant Address	505 Walnut St., Monticello, MN
Contact Phone Number	763-271-7124
Property Owner	City of Monticello
Address	
Contact Phone No	

The review and consideration of an application submitted shall occur with a written description of event including items checked below, an aerial map of location and layout of event.

All items checked below are required in support of the application and is deemed complete by the City Clerk's Office.

Check Items that Apply	
	Use of City Park
	Use of Monticello Community Center Space <small>Warehouse Room, 6am-3pm</small>
	Alcohol consumption.

	Street closure
	Event times/dates including set-up & tear-down times. Saturday, Feb. 21, 6am-3pm
	Lighting.
	Music, including bands, amplification, speakers and other possible noise.
	Parking. At MCC
	Security.
	Signage.
	Solid waste disposal (port-a-potties).
	Tent – Number and size.
	Attach a neighborhood flyer or door tag alerting residents which will be affected by event.
	Other items as requested by City Clerk.

Site plan or survey of property showing the following.

- Building and location of the event.
- Parking.
- Exact location of tents, displays related to events& activities, stages, security, lighting, food/drink areas
- Street closure

PROPERTY INFORMATION
The Monticello Community Center is partnering with Freeze Your Bass Off Fishing Tournament, a free entry small mouth bass swim bait catch and release fishing tournament along the banks of the Mississippi River. Details for this 4th annual tournament can be found here: https://fyao.square.site/

APPLICANT CHECK	APPLICATION SUBMITTAL REQUIREMENTS	CITY CHECK-IN
	Application fee: \$50 \$25 – for non-profit/charitable organization	

IF REQUESTING A WAIVER OF FEES, APPLICANTS MUST SUBMIT A PROPOSAL FOR AN ADDITIONAL COMMUNITY SERVICE PROJECT BENEFITTING THE PARKS, ARTS, & RECREATION DEPARTMENT OR THE CITY. THE PROPOSAL MUST BE APPROVED BY THE CITY CLERK.

SIGNATURE OF APPLICANT AND PROPERTY OWNER REQUIRED

By signing below, the applicant/property owner for the submitted event being held on the property named in this application agree(s) to defend, indemnify, and hold harmless the City of Monticello, Minnesota, its employees, agents, representatives, elected city officials, appointed city officials, and city council members from and against any claims, demands, suits, losses, costs, expenses (including attorney fees), or any other type of damages which may be asserted, claimed, sought, awarded, or recovered against or from the City of Monticello, Minnesota, its employees agents, representatives, elected city officials, appointed city officials, and city council members, as a result of the event by reason of any damage to the property, personal injury or bodily injury including death, sustained by any person whomsoever in which such damage, injury or death arises out of, is incidental to, or is in any way connected whatsoever with the performance of this contract, the temporary special event referenced herein, or anything connected thereto, and regardless of whether the claim, demand, damage, loss, cost, or expense is caused in whole or in part, by the event organizer and/or promoter, or any of its employees, agents, representative, the negligence of the City of Monticello, Minnesota, its employees, agents, representatives, elected city officials, appointed city officials, or city council members, or by any third parties or their agents, servants or employees.

Applicant's Signature:

Date:

Property Owner's Signature: (If different than applicant)

Date:

Office Use Only	
(City Clerk Signature)	(Date)

Notes:

FREEZE YOUR BASS OFF

SWIMBAIT TOURNAMENT

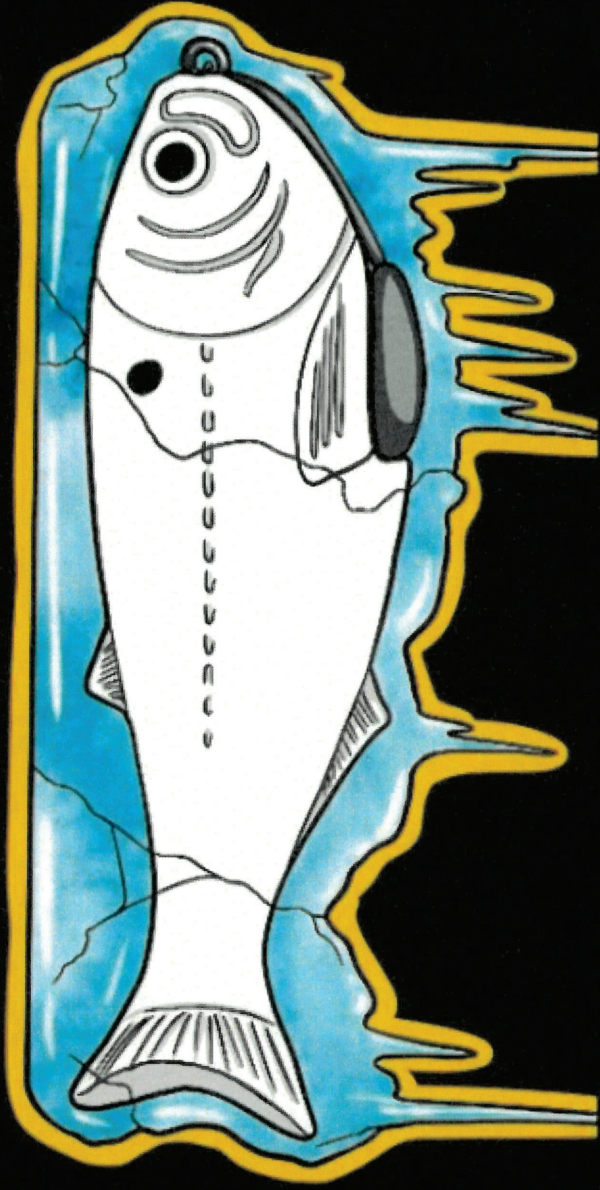

FEBRUARY 21ST, 2026
MONTICELLO, MN

2K. Consideration to approve an extension to June 11, 2026 for the approval of the Preliminary Plat and Development Stage Planned Unit Development (PUD) and for City decision on the Haven Ridge West Final Plat and Final Stage PUD

<p>Prepared by: Community Development Director</p>	<p>Meeting Date: 2/09/2026</p>	<p><input checked="" type="checkbox"/> Consent Agenda Item <input type="checkbox"/> Regular Agenda Item</p>
<p>Reviewed by: Public Works Director, Assistant City Engineer, Chief Building and Zoning Official</p>	<p>Approved by: City Administrator</p>	

ACTION REQUESTED

Motion to approve an extension to June 11, 2026 for the approval of the Preliminary Plat and Development Stage PUD and for City decision on the Haven Ridge West Final Plat and Final Stage PUD.

PREVIOUS COUNCIL ACTION

August 26, 2024: Council approved the Preliminary Plat and Development Stage PUD of Haven Ridge West, and the rezoning of the plat area to Haven Ridge West PUD.

August 11, 2025: Council approved an extension to the approval of the preliminary plat and development stage PUD and decision for final plat for Haven Ridge West.

REFERENCE AND BACKGROUND

Property: Legal Description: Outlots F, G, H, I, J, K and L, Haven Ridge
PID #: 155259000060, 155259000070,
 155259000080, 155259000090,
 155259000100, 155259000110,
 155259000120

Planning Case Number: 2025-25

Request(s): Final Plat; Final Stage Planned Unit Development

Deadline for Decision: July 8, 2025 (60-day deadline) - Applicant requested extension

Land Use Designation: Low Density Residential, Estate Residential (far southerly portion)

Zoning Designation:	Haven Ridge West Planned Unit development	
Overlays/Environmental Regulations Applicable:	N/A	
Current Site Uses:	Vacant Agriculture	
Surrounding Land Uses:	North:	Haven Ridge 2 nd Addition (Single Family Residential) and Hunter’s Crossing (Single Family Residential)
	East:	Vacant Agriculture
	South:	Vacant Agriculture
	West:	Vacant Agriculture/Rural Residential

ANALYSIS

Twin Cities Land Development, the applicant for the Haven Ridge West Preliminary Plat and Planned Unit Development (PUD), has requested a 120-day extension of the City’s decision deadline for their final plat and final stage PUD application.

Since the prior extension was granted, the applicant has continued to address matters related to final plat configuration and ownership timing for the proposed development. In their request, Twin Cities Land Development indicated their intent to proceed with the project in manner consistent with all prior approvals.

The approved preliminary plat for Haven Ridge West provides an additional 298 single-family residential units, including a range of lot sizes and home products. The plat also includes construction of a roundabout at the intersection of Fallon Avenue and 85th Street. The roundabout right-of-way and associated trunk infrastructure within the proposed Haven Ridge West represent important improvements that will support service to the City’s growth area to the south and west, including the proposed Monticello Industrial/Monticello Tech site.

The City’s Subdivision Ordinance requires submission of a complete final plat application within 360 days of preliminary plat approval. The Preliminary Plat and Development Stage PUD for Haven Ridge West were approved on August 26, 2024, concurrent with rezoning. Accordingly, the preliminary plat approval was set to expire on August 21, 2025. Twin Cities Land Development submitted its final plat and final stage PUD application materials in April 2025, meeting the required 360-day submission deadline.

The Subdivision Ordinance and state law require the City to act within 60 days of receipt of a complete final plat application and within a maximum of 120 days for the Development Stage and Final Stage PUD processes. Through its extension request, the applicant has authorized an extension to the statutory timeline for the City’s decision, as permitted by law.

The City Attorney has also recommended that the City formally consider an extension of the preliminary plat approval and the City's decision timeline for the final plat in order to fully satisfy the intent of the following subdivision ordinance provision.

(7) Approval of a preliminary plat shall be null and void unless within 360 days after receiving the last required approval of the preliminary plat there shall be submitted to the Zoning Administrator a final plat or plats for all or a portion of the approved preliminary plat in accordance with the conditions upon which approval was granted by the City Council. An extension from this requirement may be granted by the Council upon the reception of a request for extension. An extension shall be requested in writing and filed with the city at least 14 days before the voidance of the approved preliminary plat. There shall be no charge for the filing of such request. The request for extension shall state facts showing a good faith attempt was made to meet the final plat submission requirement. Such request shall be presented to the Council for a decision.

In addition, the City's Zoning Ordinance requires applicants for a Planned Unit Development to submit a final stage PUD plan and final plat that conform to the approved Development Stage PUD and preliminary plat within 60 days of Development Stage PUD approval, consistent with M.S. §15.99. Applicants may request an extension of up to six months from the Community Development Department. Twin Cities Land Development submitted a 6-month extension request to April, 2025. The April application for final plat and final stage PUD satisfied this requirement and the applicant is not requesting the Council extension for the decision on the final stage PUD to coincide with the final plat decision.

- I. **Budget Impact:** None. The applicant's escrow covers review expenses related to the plat.
- II. **Staff Workload Impact:** Minimal; limited to review of request and preparation of report.
- III. **Comprehensive Plan Impact:** The extensions support a project previously found consistent with the 2040 Plan. The proposed plat and PUD are consistent with the land use guidance provided within the Monticello 2040 plan for the Low Density and Estate Residential areas of this project. The proposed project provides a variety of housing options consistent with the 2040 policy for Neighborhood Diversity & Life-Cycle Housing's policy for "sustaining a diverse array of neighborhood character and housing types" and includes areas of conservation design and neighborhood focus.

STAFF RECOMMENDED ACTION

City staff recommend approving the extension for the preliminary plat approval and for the final plat and final stage PUD decision for Haven Ridge West. Extension of these timelines is consistent with the prior approvals and facilitates work to complete the Haven Ridge West plans and development contract, including the public infrastructure associated with the project.

SUPPORTING DATA

- A. Letter of Request, January 22, 2026
- B. Preliminary Plat of Haven Ridge West (Cover)
- C. [City Council Report, August 25, 2024](#)
- D. Subdivision Ordinance, Excerpt



January 22, 2026

City of Monticello
Attention: Angela Schumann, Community Development Director
505 Walnut Street
Monticello, MN 55362

Subject: Request for Second Extension of City Review Period
Project: Haven Ridge West, 1st Addition

Dear Ms. Schumann,

Following the City's approval of our prior extension request, Twin Cities Land Development respectfully requests a second extension of the City review period for the Final Plat and Final PUD for the Haven Ridge West, 1st Addition. We are requesting an additional 120 days, bringing the final decision date to **June 11, 2026**.

This second extension request is the result of unforeseen conditions related to our purchase strategy for the existing land, which added time to our overall development schedule. While this required additional coordination, it has **not substantially changed the proposed scope or intent of the development**, and the project is now back on track and moving forward.

Our team remains fully committed to advancing Haven Ridge West in close collaboration with the City. We anticipate moving ahead with closing on the land and beginning construction activities in 2026. Thank you for your continued partnership and consideration of this request. Please do not hesitate to contact me should you have any questions or need additional information.

Sincerely,

Carla Dunham
Twin Cities Land Development

HAVEN RIDGE WEST

MONTICELLO, MINNESOTA

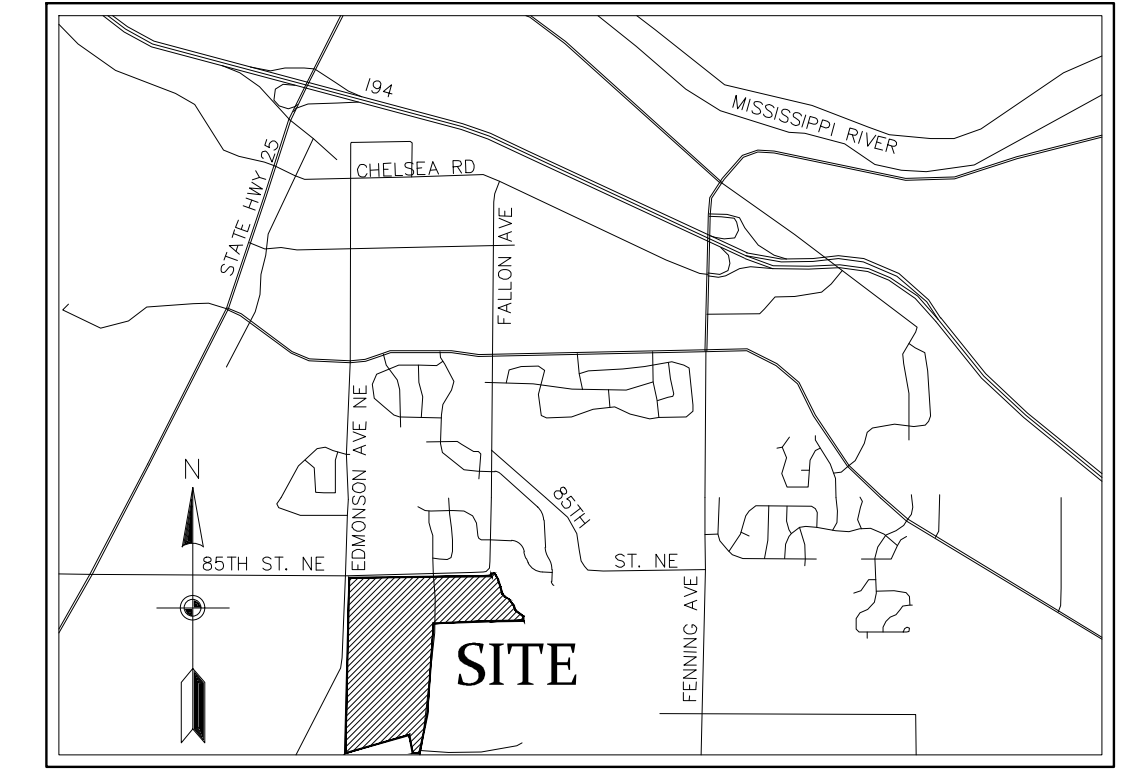

VICINITY MAP
NOT TO SCALE

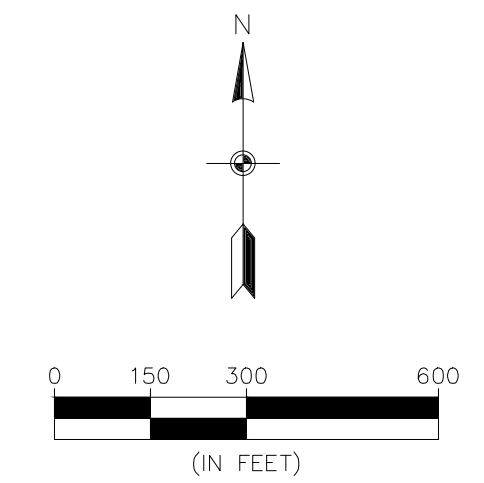

BENCHMARKS	
1. Minnesota Department of Transportation Geodetic OSD Station No. 93813 (MnDot Name Golf).	ELEVATION = 974.53 FT.
2. Minnesota Department of Transportation Geodetic OSD Station No. 93803 (MnDot Name B605 S).	ELEVATION = 966.55 FT.

SHEET INDEX

- 1. COVER
- 2. EXISTING CONDITIONS
- 3. PRELIMINARY PLAT INDEX
- 4-11. PRELIMINARY PLAT
- 12-13. REMOVALS PLAN
- 14-16. PRELIMINARY SITE & UTILITY PLAN
- 17. GRADING INDEX
- 18-24. PRELIMINARY GRADING & EROSION CONTROL PLANS
- 25-27. DETAILS
- T1-T4. TREE PRESERVATION PLAN
- L1-L6. LANDSCAPE PLAN

CALL BEFORE YOU DIG

Know what's below.
Call before you dig.

The subsurface utility information shown on this plan is utility Quality Level D. This quality level was determined according to the guidelines of C/ASCE 38-02, entitled "Standard Guideline for the Collection and Depiction of Existing Subsurface Utility Data."

§ 152.027 PROCEDURE FOR FINAL PLAT.

(A) *Filing.*

(1) After the preliminary plat has been approved, the final plat shall be submitted for review as set forth in the divisions which follow. The city may agree to review the preliminary and final plat simultaneously. The final plat shall incorporate all changes, modifications, and revisions required by the city. Otherwise, it shall strictly conform to the approved preliminary plat.

(2) The application for final plat shall be accompanied by electronic and print copies of a preliminary plat and supportive information in conformity with requirements of this chapter and application checklists.

(B) *Approval of the City Council.*

(1) The final plat shall be submitted to the Zoning Administrator for distribution to the City Council and appropriate city staff. The city staff shall examine the final plat and prepare a recommendation to the Council. The Council shall certify final approval within 60 days if the applicant has complied with all conditions and requirements of applicable regulations and conditions and requirements of the preliminary plat approval.

(2) If approved, the final plat and development agreement shall be approved by resolution, which resolution shall provide for the acceptance of all agreements for basic improvements, public dedication, and other requirements as indicated by the City Council. If disapproved, the grounds for any refusal to approve a plat shall be set forth in the proceedings of the Council and reported to the person or persons applying for such approval.

(C) *Development agreement.* Before a final plat is approved by the City Council and prior to recording or registering a final plat, the owner or subdivider of the land covered by the plat shall execute and submit to the Council an agreement, which shall be binding on his, her, or their heirs, personal representatives, and assigns, which embodies the terms and conditions of the approval given by the Council, including, but not limited to, requirements set forth in this chapter and which controls the installation of all required improvements. The agreement will require all improvements in compliance with approved engineering standards and applicable regulations. Said development agreement shall provide for the supervision and inspection of the construction by the City Engineer and shall provide for the fees and securities in connection to the improvements.

(D) *Existing special assessments.* When any existing special assessments which have been levied against the property described are to be divided and allocated to the respective lots in the proposed plat, city staff shall:

- (1) Estimate the clerical cost of preparing a revised assessment role;
- (2) File the same with the County Auditor; and
- (3) Make such division and allocation.

(E) *Recording final plat.*

(1) If the final plat and development agreement are approved by the City Council, the applicant shall record them with the County Recorder within 100 days after the approval or approval of the final plat shall be considered void, unless a request for a time extension is submitted in writing and approved by the Council. The applicant shall, immediately upon recording, furnish the Zoning Administrator with a print and reproducible tracing of the final plat showing evidence of the recording.

(2) A final plat will not be released by the city for recording purposes until the applicant has satisfied applicable ministerial requirements of this chapter, including payment of fees, execution of a developer's agreement, deposit of surety, letters of credit, Mylar copies of the final plat, easement and deed documents, and all other requirements of approval by resolution.

(3) No building permits shall be let for construction of any structure on any lot in the plat until the construction plans have been approved by the city, the city has received evidence of the plat and development agreement being recorded by the county and the provisions of the subdivision's development agreement have been satisfactorily met.

(F) *Recording of multiple-phased plats.* If a preliminary plat is final platted in stages, unless otherwise provided for in the development contract, all stages must be final platted into lots and blocks (not outlots) within three years after the preliminary plat has been approved by the City Council. If the final plats are not approved and recorded in accordance with this time frame, the preliminary plat approval shall be considered void, unless a request for time extension is submitted in writing and approved by the Council prior to the expiration of the three-year period.

(G) *Extension.* Within 30 days of the deadline of recording of the final plat, the applicant may file with the Zoning Administrator a written request that said deadline be extended six months beyond the date the extension is granted. The Zoning Administrator shall place the request on the agenda of a regularly scheduled City Council meeting to be held within 30 days of the extension filing if in their opinion no change has occurred in any land use restriction or the Comprehensive Plan, or any other official control affecting the use, development density, lot size, lot layout, or dedication or platting required or permitted by the preliminary plat.

2L. Consideration of adopting Resolution 2026-04 accepting public utilities for the Meadowbrook Development

<p>Prepared by: Assistant City Engineer</p>	<p>Meeting Date: 2/9/2026</p>	<p><input checked="" type="checkbox"/> Consent Agenda Item <input type="checkbox"/> Regular Agenda Item</p>
<p>Reviewed by: Finance Director, Community Development Director, Public Works Director/City Engineer</p>	<p>Approved by: City Administrator</p>	

ACTION REQUESTED

Motion to adopt Resolution 2026-04 accepting public utilities for the Meadowbrook Development.

REFERENCE AND BACKGROUND

The Meadowbrook plat includes developer-installed public improvements including streets, sidewalks, signage, mailboxes, streetlights, and public utilities. Construction of the improvements was recently completed, and they have been inspected, tested and approved for compliance with the City’s standard specifications by the Engineering and Public Works Departments.

In accordance with the development agreement, the developer provided financial security to ensure completion of the public improvements. Staff now recommend that the City Council accept the public utilities portion of the public improvements and reduce the letter of credit. The developer’s contractor has submitted a two-year warranty bond for the public utilities, which expire in February 2028.

A portion of the securities for grading, streets, curb, sidewalk, trail and landscaping will be retained until all vegetation is fully established and the related warranties are complete. Once the street wear course has been installed, Council will be asked to accept the sidewalk, trail, curb and street improvements, at which time a two-year warranty bond will be required from the contractor.

- I. **Budget Impact:** N/A
- II. **Staff Workload Impact:** N/A
- III. **Comprehensive Plan Impact:** N/A

STAFF RECOMMENDED ACTION

City staff recommend adopting Resolution 2026-04 accepting public utilities for the Meadowbrook development.

SUPPORTING DATA

- Resolution 2026-04

**CITY OF MONTICELLO
WRIGHT COUNTY, MINNESOTA**

RESOLUTION NO. 2026-04

**RESOLUTION ACCEPTING PUBLIC UTILITIES
FOR THE MEADOWBROOK PUBLIC IMPROVEMENTS**

WHEREAS, the Meadowbrook Development Contract approved on April 28, 2025, and

WHEREAS, the public utility improvements included Sanitary Sewer, Watermain, and Storm sewer in the Meadowbrook Plat; and

NOW THEREFORE, BE IT RESOLVED BY THE CITY OF MONTICELLO, MINNESOTA that the public Utility improvements completed under said contract is hereby accepted and approved and that the Mayor and City Clerk are hereby directed:

- 1) Accept public utilities improvements and reduce letter of credit for security of the 2-year warranty bond.

ADOPTED BY the Monticello City Council this 9th day of February, 2026.

CITY OF MONTICELLO

Lloyd Hilgart, Mayor

ATTEST:

Jennifer Schreiber, City Clerk

2M. Consideration of authorizing the purchase of a 2027 Volvo VHD Tandem Axle Cab and Chassis from Nuss Truck & Equipment equipped with Force America controls, a dump body and Falls plow equipment from Towmaster and purchase of associated auto greaser from Lubecore MN for a net cost of \$345,499.22 and to declare the current Truck 116 as surplus

Prepared by: Street Superintendent	Meeting Date: 02/09/2026	<input checked="" type="checkbox"/> Consent Agenda Item <input type="checkbox"/> Regular Agenda Item
Reviewed by: PW Director/City Engineer, Finance Director	Approved by: City Administrator	

ACTION REQUESTED

Motion to authorize purchase of a 2027 Volvo VHD tandem axel cab and chassis from Nuss Truck & Equipment equipped with Force America controls, a dump body and Falls plow equipment from Towmaster and purchase of associated auto greaser from Lubecore MN for a net cost of \$345,499.22 and to declare the current Truck 116 as surplus.

REFERENCE AND BACKGROUND

The 2026 budget includes \$400,000 for the purchase of a new plow truck. Staff request authorization to purchase a 2027 Volvo VHD tandem axle cab and chassis from Nuss Truck and Equipment of Mankato, MN outfitted with additional equipment as listed below. The final cost includes the trade-in value for the existing plow truck being replaced.

Company	Equipment	Cost
Nuss Truck & Equipment	Volvo Cab & Chassis	\$170,807.22
Towmaster	Dump Body, Snowplow Equipment, Force America Controls	\$212,342
Lubecore MN	Automatic Lubrication System	\$10,350
		\$393,499.22
Nuss Truck & Equipment	Trade-In Value for 2012 Mack	(\$48,000)
		\$345,499.22

The new truck will replace the City's 2012 Mack Granite hook/plow truck. Although the City operated a 2008 Sterling plow truck that is older, staff recommend replacing the 2012 Mack truck first due to ongoing reliability issues and downtime. The 2012 truck has had ongoing mechanical and electrical issues, including failures related to its first-generation diesel exhaust system and more recent computer and wiring failures. Replacement parts are difficult to obtain, resulting in increased downtime and repair costs. Over \$50,000 in repairs beyond normal maintenance have been required, including \$14,983.98 for recent computer and wiring harness repairs.

Two cab and chassis were evaluated through the state contract: Mack and Volvo. The Volvo was \$122.32 more expensive than the Mack; however, the City currently owns two Volvo trucks with positive performance history, and operators prefer the Volvo cab configuration. Based on these factors, staff recommend purchasing the Volvo.

There are two companies in Minnesota that outfit plow equipment. Due to past performance experience, staff recommend outfitting the truck with Towmaster equipment. Towmaster has outfitted all but one of the plows and has the strongest results. Installation of the plow equipment is anticipated in 2027.

Finally, staff recommend utilizing the Lubecore auto-greaser to maintain fleet consistency and prevent having to stock different styles of grease cartridges.

- I. **Budget Impact:** The 2026 Central Equipment Fund budget includes \$400,000 for the replacement of one plow truck. The Towmaster plow equipment will not be installed until 2027, therefore the 2027 Central Equipment Fund budget will reflect that cost.
- II. **Staff Workload Impact:** Improve efficiency with time, vehicle failure and safety.
- III. **Comprehensive Plan Impact:** N/A

STAFF RECOMMENDED ACTION

Staff recommend purchase of the 2027 Volvo and associated equipment as noted and declaring the Truck 116 2012 Mack as surplus.

SUPPORTING DATA

- Quotes

202 DRAFT

TANDEM AXLE CAB/CHASSIS

Exhibit D: Price Schedule

VENDOR NAME **Nuss Truck and Equipment**

MAKE AND MODEL **2025 Volvo VHD 64F300 TA**

This section for use when ordering

WB	216"	
CA	131"	Grand Total \$ 170,807.22
AF	79"	
Rear Ratio	4.33	
Cab Color	Orange	
Wheel Color	Alum	
Notes	NUSS20250000185092D - City Of Monticello	

Code	Spec #	Description	Qty	2025 Price	Subtotal
VHD64F300	1.0	Price for Base Unit:	1	\$ 125,579.00	\$ 125,579.00

2.0 FRAME OPTIONS

x4XB1X	2.1	Front frame extension	1	\$ 143.00	\$ 143.00
x2345	2.2	Custom hole punching in frame		\$ 110.00	\$ -
994DX	2.3	Deduct for no front bumper		\$ (60.00)	\$ -
403003	2.4	Frame fastener option (bolt or huck spun)	1	STD	
	2.5	Frame, R.B.M., S.M., PSI, CT			\$ -
403005	2.6	11.81"x3.54"x.31", R.B.M. 2,112,000, S.M. 17.6, PSI,120,000 CT	0	STD	
403006	2.7	11.81"x3.54"x.38", R.B.M. 2,460,000, S.M. 20.5, PSI,120,000 CT		\$ 343.00	\$ -
403010	2.8	11.81"x3.54"x.44", R.B.M. 2,820,000, S.M. 23.5, PSI,120,000 CT	0	\$ 562.00	\$ -
403011	2.9	11.81"x4.13"x.44", R.B.M. 3,156,000, S.M. 26.3, PSI,120,000 CT	1	\$ 720.00	\$ 720.00

3.0 FRONT AXLE/SUSPENSION/BRAKE/OPTION

MC	3.1	Set Forward Front Axle Option	1	STD	
370403	3.2	14,600 front axle and matching suspension	1	STD	
370405	3.3	16,500 front axle and matching suspension		\$ 875.00	\$ -
370406	3.4	18,800 front axle & matching suspension		\$ 978.00	\$ -
370407	3.5	20,800 front axle and matching suspension	1	\$ 1,079.00	\$ 1,079.00
370408	3.6	22,800 front axle and matching suspension Volvo F22		\$ 1,154.00	\$ -
371071	3.7	Heavy duty front axle shocks	0	\$ 50.00	\$ -
782014	3.8	Front Brake Dimension 16.5x6	1	\$ 67.00	\$ 67.00
0KXG1X	3.9	Hubs Front axle iron unitized front axle hubs	1	\$ 25.00	\$ 25.00
NA	3.10	Right hand air bag suspension per Spec 3.7, Driver controlled		No Bid	
NA	3.11	Left air bag suspension per Spec 3.7, Driver controlled		No Bid	
ZGXE1X	3.12	Front axle lubrication cap with slotted venthole		No Bid	
UDXA1X	3.13	Front brake dust shields	1	STD	
XEXB1X	3.14	Dual front auxiliary steering gear	1	\$ 1,464.00	\$ 1,464.00
0371074	3.15	Multi Leaf Front Susp (RH Stiffner)		\$ 91.00	\$ -
XEXA1X	3.16	Right Hand Ram Assist		\$ 1,230.00	\$ -

4.0 TANDEM REAR AXLE/SUSPENSION/BRAKE/OPTIONS

350380	4.1	46,000# rear axle & matching suspension Meritor RT46-160 & Volvo 46k T-Ride	1	\$ 1,932.00	\$ 1,932.00
350360	4.2	40,000# walking beam rear suspension and axle Make & Model - Meritor MT-40-14X4D with Hendrickson HMX EX 400		\$ 791.00	\$ -
350350	4.3	46,000# walking beam rear suspension and axle Make & Model - Meritor MT-46-160 with Hendrickson HMX EX 460		\$ 2,184.00	\$ -
350324	4.4	40,000# air suspension and axle Make & Model - Meritor MT-40-14X4D & HAS-400		\$ 510.00	\$ -
350312	4.5	46,000# air suspension and axle Make & Model - Meritor RT-46-160 & HAS-460		\$ 2,276.00	\$ -
350324-1	4.6	Dash mounted air dump system		\$ 243.00	\$ -
TUXD1X	4.7	Driver activated differential lock on one rear axle (front axle ____ rear axle ____, check one)		\$ 360.00	\$ -
TUXA1X	4.8	Driver activated differential lock on both front and rear axles		\$ 703.00	\$ -
MC	4.9	Driver activated differential lock on both front and rear axles, and lubrication pump and filter system	1	\$ 974.00	\$ 974.00
MC	4.10	Meritor RT-46-160P, both axles driver differential lock and pump, HMX460 46,000 # walking beam suspension		\$ 2,688.00	\$ -
NA	4.11	½ round universal joints	1	STD	
THXC2X	4.12	Spicer 1810 HD drive line with half round universal joints		\$ 230.00	\$ -
UEXA1X	4.13	Rear brake dust shield	1	\$ 40.00	\$ 40.00
350377	4.14	40,000lb Volvo T Ride Suspension (2 leaf firm ride) 54" spacing	0	STD	
35078	4.15	40,000lb Volvo T Ride Suspension (3 leaf firm ride) 54" spacing		\$ 138.00	\$ -

784013	4.16	Meritor Brake Adjuster Front and Rear	1	\$ 11.00	\$ 11.00
UKXB1X	4.17	Extended length brake stroke		\$ 54.00	\$ -
781104	4.18	Fur Cam type haldex life seal plus		\$ 107.00	\$ -
7WXB1X	4.19	Synthetic Rear Axle Lubricant	1	\$ 117.00	\$ 117.00
yVXA1X	4.20	Rear Shock Absorbers	1	\$ 350.00	\$ 350.00
R4XA1X	4.21	Rear Axle Lube Pump		\$ 320.00	\$ -
330684	4.22	Meritor MT-40-14X4D Hypoid Rear Axle 40,000lb capacity	1	STD	

5.0 FIFTH WHEEL OPTIONS

X6XA2X	5.1	Frame end tapered and open		\$ 12.00	\$ -
X6XB2X	5.2	Frame end tapered and closed		\$ 30.00	\$ -
330AB7	5.3	Fixed fifth wheel - Holland FW-35		\$ 684.00	\$ -
330AE7	5.4	Mechanical slide fifth wheel - Holland FW35, Travel - 24" slide		\$ 562.00	\$ -
330AH4	5.5	Air slide fifth wheel - Holland FW35, Travel - 24" slide		\$ 986.00	\$ -
464AA5	5.6	Stainless 1/4 fenders, mounted front of tandems		\$ 127.00	\$ -
464AA2	5.7	Plastic 1/4 fenders, mounted front of tandems		\$ 110.00	\$ -
WHX01X	5.8	Tractor package hookup		\$ 297.00	\$ -
7KXA3X	5.9	Behind cab deck plate		\$ 681.00	\$ -
330AB8	5.10	Holland fixed with non-tilt 5th wheel		\$ 1,385.00	\$ -
330AEF	5.11	Holland manual slide 5th wheel		\$ 537.00	\$ -
69XD3X	5.12	Mud flaps with brackets		\$ 115.00	\$ -
69XC3X	5.13	Betts B60 stainless steel angled mud flap brackets		\$ 161.00	\$ -
51XD1X	5.14	Hose tender & towel bar assembly		\$ 58.00	\$ -
5ZXB1X	5.15	Coiled trailer air hose		\$ 39.00	\$ -
2UAB1X	5.16	Coiled trailer electrical hose		\$ 44.00	\$ -
OBS04S	5.17	Air Weight AW5800 onboard scales		\$ 1,118.00	\$ -
6HXBRX	5.18	Medium height 5th wheel ramp guide		\$ 228.00	\$ -
322022	5.19	Trailer hook up light		\$ 74.00	\$ -

6.0 TIRES/RIMS OPTIONS:

NA	6.1	Nylon wafers or wheel guards on all wheels (10 ea)	1	\$ 44.00	\$ 44.00
NA	6.2	Heavier 7500 lb 22.5 x 8.25 Steel rims in lieu of standard 7300# rims (10 ea)	0	STD	
084441	6.3	22.5 12.5 Black Powder quoted wheels front and back		\$ 482.00	\$ -
NA	6.4	Heavier 7500 lb 22.5 x 8.25 Steel rims in lieu of standard 7300# rims (8 ea) in rear only		\$ (16.00)	\$ -
		Front Tire Package			
093760	6.5	11R22.5H GOODYEAR G731 MSA (13220 LBS. GAWR) MULTI USAGE		\$ 288.00	\$ -
093762	6.6	11R22.5H GOODYEAR G751 MSA (13220 LBS. GAWR) MULTI USAGE		\$ 258.00	\$ -
093299	6.7	11R24.5H BRIDGESTONE M863 (14320 LBS. GAWR) ON/OFF ROAD USAGE		\$ 2,240.00	\$ -
093562	6.8	11R24.5H BRIDGESTONE R250ED (14320 LBS. GAWR) REGIONAL / URBAN USAGE		\$ (85.00)	\$ -
093741	6.9	11R24.5H BRIDGESTONE R268 (14320 LBS. GAWR) REGIONAL / URBAN USAGE		\$ (75.00)	\$ -
093796	6.10	11R24.5H BRIDGESTONE R283A ECOPIA (14320 LBS. GAWR) LONG / REGIONAL HAUL		\$ (85.00)	\$ -
093761	6.11	11R24.5H GOODYEAR G731 MSA (14320 LBS. GAWR) MULTI USAGE		\$ 380.00	\$ -
093763	6.12	11R24.5H GOODYEAR G751 MSA (14320 LBS. GAWR) MULTI USAGE		\$ 335.00	\$ -
093591	6.13	11R24.5H MICHELIN XZE2 (14320 LBS. GAWR) REGIONAL / URBAN USAGE		\$ 1,648.00	\$ -
093804	6.14	11R24.5H MICHELIN X WORKS Z (14320 LBS. GAWR) ON/OFF ROAD USAGE		\$ 100.00	\$ -
093764	6.15	12R22.5H GOODYEAR G751 MSA (14780 LBS. GAWR) MULTI USAGE		\$ 468.00	\$ -
093805	6.16	12R24.5H MICHELIN X WORKS Z (15660 LBS. GAWR) ON/OFF ROAD USAGE		\$ 210.00	\$ -
093790	6.17	275/80R22.5H MICHELIN X LINE ENERGY Z (14320 LBS. GAWR) LONG / REGIONAL HAUL		\$ (40.00)	\$ -
093758	6.18	315/80R22.5L GOODYEAR G751 MSA (18180 LBS. GAWR) MULTI USAGE		\$ 675.00	\$ -
093828	6.19	315/80R22.5L MICHELIN X LINE ENERGY Z (18180 LBS. GAWR) LONG HAUL		\$ 95.00	\$ -
093806	6.20	315/80R22.5L MICHELIN X WORKS Z (18180 LBS. GAWR) ON/OFF ROAD USAGE		\$ 235.00	\$ -
093672	6.21	315/80R22.5L MICHELIN XZUS2 (20000 LBS. GAWR) URBAN USAGE	1	\$ 245.00	\$ 245.00
093823	6.22	315/80R22.5L CONTINENTAL CITY SERVICE HA3 (20000 LBS. GAWR) URBAN USAGE		\$ 450.00	\$ -
093747	6.23	385/65R22.5J BRIDGESTONE M854 (18740 LBS. GAWR) ON/OFF ROAD USAGE		\$ 200.00	\$ -
093495	6.24	385/65R22.5J MICHELIN XZY3 (18740 LBS. GAWR) ON/OFF ROAD USAGE		\$ 265.00	\$ -

093567	6.25	385/65R22.5L MICHELIN XFE (19840 LBS. GAWR) ON/OFF ROAD USAGE		\$ 335.00	\$ -
		Rear Tire Package			
094673	6.26	11R22.5G BRIDGESTONE M770 (23360 LBS. GAWR) LONG / REGIONAL HAUL		\$ 225.00	\$ -
094810	6.27	11R22.5G BRIDGESTONE M726 EL A (21660 LBS. GAWR) LONG / REGIONAL HAUL		\$ 135.00	\$ -
094297	6.28	11R22.5G BRIDGESTONE M843 (23360 LBS. GAWR) ON/OFF ROAD USAGE		\$ 690.00	\$ -
094736	6.29	11R22.5G BRIDGESTONE R268 (23360 LBS. GAWR) REGIONAL HAUL	1	STD	
094821	6.30	11R22.5G CONTINENTAL HDL2 (22700 LBS. GAWR) LONG HAUL		\$ 595.00	\$ -
094701	6.31	11R22.5G MICHELIN X LINE ENERGY D (23360 LBS. GAWR) LONG / REGIONAL HAUL		\$ 1,085.00	\$ -
094350	6.32	11R22.5G MICHELIN XDN2 (23360 LBS. GAWR) LONG / REGIONAL HAUL		\$ 930.00	\$ -
094788	6.33	11R22.5G MICHELIN X LINE ENERGY Z (23360 LBS. GAWR) LONG / REGIONAL HAUL		\$ 835.00	\$ -
094588	6.34	11R22.5G MICHELIN XZE2 (23360 LBS. GAWR) REGIONAL / URBAN USAGE		\$ 635.00	\$ -
094692	6.35	11R22.5G MICHELIN X MULTI ENERGY D (23360 LBS. GAWR) REGIONAL HAUL		\$ 965.00	\$ -
094674	6.36	11R22.5H BRIDGESTONE M770 (24020 LBS. GAWR) LONG / REGIONAL HAUL		\$ 465.00	\$ -
094559	6.37	11R22.5H BRIDGESTONE M775 (24020 LBS. GAWR) ON/OFF ROAD USAGE		\$ 889.00	\$ -
094311	6.38	11R22.5H BRIDGESTONE M843 (24020 LBS. GAWR) ON/OFF ROAD USAGE		\$ 915.00	\$ -
094738	6.39	11R22.5H BRIDGESTONE R268 (24020 LBS. GAWR) REGIONAL / URBAN USAGE		\$ 465.00	\$ -
094688	6.40	11R22.5H BRIDGESTONE M799 (24020 LBS. GAWR) ON/OFF ROAD USAGE		\$ 565.00	\$ -
094760	6.41	11R22.5H GOODYEAR G731 MSA (24020 LBS. GAWR) MULTI USAGE		\$ 2,470.00	\$ -
094762	6.42	11R22.5H GOODYEAR G751 MSA (24020 LBS. GAWR) MULTI USAGE		\$ 2,355.00	\$ -
094351	6.43	11R22.5H MICHELIN XDN2 (24020 LBS. GAWR) LONG / REGIONAL HAUL	1	\$ 1,015.00	\$ 1,015.00
094652	6.44	11R22.5H MICHELIN XDS2 (24020 LBS. GAWR) LONG / REGIONAL HAUL		\$ 1,485.00	\$ -
094789	6.45	11R22.5H MICHELIN X LINE ENERGY Z (24020 LBS. GAWR) LONG / REGIONAL HAUL		\$ 955.00	\$ -
094801	6.46	11R22.5H MICHELIN X WORKS Z (24020 LBS. GAWR) ON/OFF ROAD USAGE		\$ 1,345.00	\$ -
094686	6.47	11R22.5H MICHELIN X WORKS XDY (24020 LBS. GAWR) ON/OFF ROAD USAGE		\$ 1,485.00	\$ -
094677	6.48	11R24.5G BRIDGESTONE M770 (24020 LBS. GAWR) LONG / REGIONAL HAUL		\$ 500.00	\$ -
094811	6.49	11R24.5G BRIDGESTONE M726 EL A (22700 LBS. GAWR) LONG / REGIONAL HAUL		\$ 250.00	\$ -
094739	6.50	11R24.5G BRIDGESTONE R268 (24020 LBS. GAWR) REGIONAL / URBAN USAGE		\$ 400.00	\$ -
094361	6.51	11R24.5G MICHELIN XDN2 (24020 LBS. GAWR) LONG / REGIONAL HAUL		\$ 1,185.00	\$ -
094557	6.52	11R24.5H BRIDGESTONE L320 (26440 LBS. GAWR) ON/OFF ROAD USAGE		\$ 1,315.00	\$ -
094558	6.53	11R24.5H BRIDGESTONE M775 (26440 LBS. GAWR) ON/OFF ROAD USAGE		\$ 1,525.00	\$ -
094299	6.54	11R24.5H BRIDGESTONE M843 (26440 LBS. GAWR) ON/OFF ROAD USAGE		\$ 1,185.00	\$ -
094741	6.55	11R24.5H BRIDGESTONE R268 (26440 LBS. GAWR) REGIONAL / URBAN USAGE		\$ 685.00	\$ -
094689	6.56	11R24.5H BRIDGESTONE M799 (26440 LBS. GAWR) ON/OFF ROAD USAGE		\$ 685.00	\$ -
094761	6.57	11R24.5H GOODYEAR G731 MSA (26440 LBS. GAWR) MULTI USAGE		\$ 2,845.00	\$ -
094763	6.58	11R24.5H GOODYEAR G751 MSA (26440 LBS. GAWR) MULTI USAGE		\$ 2,655.00	\$ -
094659	6.59	11R24.5H MICHELIN XDS2 (26440 LBS. GAWR) LONG / REGIONAL HAUL		\$ 1,460.00	\$ -
094804	6.60	11R24.5H MICHELIN X WORKS Z (26440 LBS. GAWR) ON/OFF ROAD USAGE		\$ 1,680.00	\$ -
094671	6.61	11R24.5H MICHELIN X WORKS XDY (26440 LBS. GAWR) LIGHT CONSTRUCTION		\$ 1,795.00	\$ -
094560	6.62	12R22.5H BRIDGESTONE M775 (27120 LBS. GAWR) ON/OFF ROAD USAGE		\$ 1,690.00	\$ -
094690	6.63	12R22.5H BRIDGESTONE M799 (27120 LBS. GAWR) ON/OFF ROAD USAGE		\$ 1,825.00	\$ -
094764	6.64	12R22.5H GOODYEAR G751 MSA (27120 LBS. GAWR) MULTI USAGE		\$ 3,195.00	\$ -

094314	6.65	12R24.5H BRIDGESTONE M843 (28640 LBS. GAWR) ON/OFF ROAD USAGE		\$ 1,465.00	\$ -
094330	6.66	275/80R22.5G MICHELIN XDA ENERGY (22700 LBS. GAWR) LONG / REGIONAL HAUL		\$ 895.00	\$ -
094700	6.67	275/80R22.5G MICHELIN X LINE ENERGY D (22700 LBS. GAWR) LONG / REGIONAL HAUL		\$ 855.00	\$ -
094698	6.68	275/80R22.5G MICHELIN XDA5+ (22700 LBS. GAWR) LONG / REGIONAL HAUL		\$ 665.00	\$ -
094354	6.69	275/80R22.5G MICHELIN XDN2 (22700 LBS. GAWR) LONG / REGIONAL HAUL		\$ 750.00	\$ -
094787	6.70	275/80R22.5G MICHELIN X LINE ENERGY Z (22700 LBS. GAWR) LONG / REGIONAL HAUL		\$ 715.00	\$ -
094694	6.71	275/80R22.5G MICHELIN X MULTI ENERGY D (22700 LBS. GAWR) REGIONAL HAUL		\$ 1,050.00	\$ -
094592	6.72	275/80R22.5G MICHELIN XZE2 (22700 LBS. GAWR) REGIONAL / URBAN USAGE		\$ 545.00	\$ -
094790	6.73	275/80R22.5H MICHELIN X LINE ENERGY Z (26440 LBS. GAWR) LONG / REGIONAL HAUL		\$ 875.00	\$ -
094699	6.74	275/80R24.5G MICHELIN XDA5+ (22700 LBS. GAWR) LONG / REGIONAL HAUL		\$ 600.00	\$ -
094490	6.75	275/80R24.5G MICHELIN XDN2 (22700 LBS. GAWR) LONG / REGIONAL HAUL		\$ 800.00	\$ -
094791	6.76	275/80R24.5G MICHELIN X LINE ENERGY Z (22700 LBS. GAWR) LONG / REGIONAL HAUL		\$ 750.00	\$ -
094809	6.77	285/75R24.5G BRIDGESTONE M726 EL A (20820 LBS. GAWR) LONG / REGIONAL HAUL		\$ 230.00	\$ -
094676	6.78	285/75R24.5G BRIDGESTONE M770 (22700 LBS. GAWR) LONG / REGIONAL HAUL		\$ 285.00	\$ -
094808	6.79	295/75R22.5G BRIDGESTONE M726 EL A (20280 LBS. GAWR) LONG / REGIONAL HAUL		\$ 75.00	\$ -
094725	6.80	295/75R22.5G BRIDGESTONE R268 (22700 LBS. GAWR) REGIONAL HAUL		\$ 95.00	\$ -
094767	6.81	295/75R22.5G CONTINENTAL HDR2 (22700 LBS. GAWR) REGIONAL HAUL		\$ 155.00	\$ -
NUS225	6.82	Steel spare rim, size		No Bid	
NUS245	6.83	Steel spare rim, size		No Bid	

	7.0	BRAKE SYSTEM OPTIONS:			
VHXBVX	7.1	Wabco System Saver 1200 Plus heated air dryer	1	STD	
UWXB1X	7.2	Manual cable drain valves on air tanks		\$ 27.00	\$ -
N/A	7.3	Heated air tank		No Bid	
UWXE3X	7.4	Auto drain valves on air tanks, heated		\$ 48.00	\$ -
300AD0	7.5	MGM type TR-T rear brake chambers		\$ 48.00	\$ -
N/A	7.6	S.S. pins on slack adjuster yoke (2 ea. per yoke) For all air brake chambers		No Bid	
N5FAJX	7.7	Inverted rear brake chamber mounting in lieu of regular mounting		No Bid	
MC	7.8	Relocate air dryer		\$ 272.00	\$ -

	8.0	ENGINE/EXHAUST AND FUEL TANKS OPTIONS: (List Make & Model, H.P., torque of engine and exhaust and fuel tank options)			
1017V0	8.1	VOLVO D11 325HP 2100RPM 1250 LBFT	1	STD	
1017V1	8.2	VOLVO D11 355HP 2100RPM 1250 LBFT		\$ 1,230.00	\$ -
1017V2	8.3	VOLVO D11 365HP 2100RPM 1350 LBFT		\$ 1,675.00	\$ -
1017V3	8.4	VOLVO D11 385HP 2100RPM 1450 LBFT		\$ 2,413.00	\$ -
1017V5	8.5	VOLVO D11 425HP 2100RPM 1550 LBFT		\$ 3,971.00	\$ -
1017V4	8.6	VOLVO D11 385HP 2100RPM 1450/1250 LBFT ECO-TORQUE PERF		\$ 2,413.00	\$ -
1017V6	8.7	VOLVO D11 425HP 2100RPM 1550/1350 LBFT ECO-TORQUE PERF		\$ 3,971.00	\$ -
1017W0	8.8	VOLVO D13 375HP 2100RPM 1450 LBFT		\$ 2,229.00	\$ -
1017W1	8.9	VOLVO D13 405HP 2100RPM 1450 LBFT		\$ 3,283.00	\$ -
1017W8	8.10	VOLVO D13 425HP 2100RPM 1550 LBFT	1	\$ 4,432.00	\$ 4,432.00
1017X7	8.11	VOLVO D13 435HP 2100RPM 1650 LBFT		\$ 4,994.00	\$ -
1017X8	8.12	VOLVO D13 455HP 2100RPM 1750 LBFT		\$ 5,649.00	\$ -
1017Y7	8.13	VOLVO D13 500HP 2100RPM 1850 LBFT		\$ 7,129.00	\$ -
1017W2	8.14	VOLVO D13 405HP 2100RPM 1450/1650 LBFT DUAL-TORQUE		\$ 3,588.00	\$ -
1017W9	8.15	VOLVO D13 425HP 2100RPM 1450/1750 LBFT DUAL-TORQUE		\$ 4,736.00	\$ -
1017X9	8.16	VOLVO D13 455HP 2100RPM 1550/1850 LBFT DUAL-TORQUE		\$ 6,000.00	\$ -
1017W3	8.17	VOLVO D13 405HP 2100RPM 1650/1450 LBFT ECO-TORQUE PERF.		\$ 3,588.00	\$ -
1017W4	8.18	ECON.		\$ 3,588.00	\$ -
1017X0	8.19	VOLVO D13 425HP 2100RPM 1750/1450 LBFT ECO-TORQUE PERF.		\$ 4,736.00	\$ -
1017X1	8.20	VOLVO D13 425HP 2100RPM 1750/1450 LBFT ECO-TORQUE ECON		\$ 4,736.00	\$ -
1017Y0	8.21	VOLVO D13 455HP 2100RPM 1850/1550 LBFT ECO-TORQUE PERFORMANCE		\$ 6,000.00	\$ -
1017Y1	8.22	VOLVO D13 455HP 2100RPM 1850/1550 LBFT ECO-TORQUE ECON		\$ 6,000.00	\$ -
1017Y8	8.23	VOLVO D13 500HP 2100RPM 1850/1550 LBFT ECO-TORQUE PERF.		\$ 7,129.00	\$ -
232088	8.24	10' 0" ALUMINIZED STAINLESS VERTICAL STEEL SINGLE STACK	1	STD	

K0XC1X	8.25	STRAIGHT END EXHAUST STACK		\$ 45.00	\$ -
K0XD1X	8.26	TURNT OUT EXHAUST EXTENSION integrated DPF and SCR	1	\$ 979.00	\$ 979.00
K0XC4X	8.27	STRAIGHT STACK, SIDE OUTLET DIFFUSER BOX	1	STD	
K0XC5X	8.28	STRAIGHT STACK, TOP OUTLET DIFFUSER BOX		\$ 45.00	\$ -
J8XATX	8.29	50 GALLON LEFT HAND FUEL TANK		\$ 132.00	\$ -
J8XBXX	8.30	70 GALLON LEFT HAND FUEL TANK		\$ 132.00	\$ -
J8XB1X	8.31	75 GALLON LEFT HAND FUEL TANK STANDARD	0	STD	
J8XEJX	8.32	90 GALLON LEFT HAND FUEL TANK	1	\$ 560.00	\$ 560.00
J8EWX	8.33	100 GALLON LEFT HAND FUEL TANK		\$ 137.00	\$ -
J8XG1X	8.34	125 GALLON LEFT HAND FUEL TANK		\$ 301.00	\$ -
JBZZ1234		22" DIA D SHAPED FUEL TANK **Required for CBOC** air tanks			
	8.35	needs moved	1	\$ 601.00	\$ 601.00
KNXB2X	8.36	26" DIA D SHAPED FUEL TANK		\$ 186.00	\$ -

includes double step

9.0 ENGINE RELATED OPTIONS:

26X1XZ	9.1	Oil fill and dipstick EZ access		\$ 319.00	\$ -
PJXMGX	9.2	Delco 35 SI Brushless Alternator, 135 AMP		\$ (44.00)	\$ -
NA	9.3	Delco 24 SI Alternator, 130 AMP	1	STD	160a
PJXMLX	9.4	Delco 24 SI Alternator, 145 AMP		\$ (50.00)	\$ -
PJXMIX	9.5	Leece-Neville Alternator, 145 AMP		\$ (35.00)	\$ -
810113	9.6	3 Volvo 760 CCA Maintenance Free 12V Batteries 2280 CCA	1	\$ 80.00	\$ 80.00
KWXA3X	9.7	Dual element air cleaner		\$ 66.00	\$ -
KWXA1A	9.8	Donaldson Single Stage Air cleaner per spec 12.1		\$ 32.00	\$ -
JVXDAX	9.9	Davco 382 fuel/water separator, non heated	1	\$ 196.00	\$ 196.00
JVXBBX	9.10	Non-heated fuel/water separator, _____ RACOR 6903E_(Brand)		\$ 42.00	\$ -
H9XK1X	9.11	Coolant spin on filter/conditioner		\$ 67.00	\$ -
T1XA1X	9.12	Front engine powered take off adapter and radiator cut out		\$ 540.00	\$ -
208021	9.13	Air applied fan drive, _____ KYSOR_(Brand)		\$ 329.00	\$ -
208025	9.14	Viscous fan drive		\$ 29.00	\$ -
KOXD1X	9.15	Curved exhaust pipe end		\$ 24.00	\$ -
5NXAVX	9.16	Engine block heater	0	\$ 60.00	\$ -
NA	9.17	In line fuel heater		No Bid	
JRXA1X	9.18	In tank fuel heater		\$ 388.00	\$ -
NA	9.19	Fuel cooler		No Bid	
NA	9.20	Radiator bug screen	1	STD	
LCO01	9.21	Stainless Steel Oil Pan	1	\$ 1,900.00	\$ 1,900.00
HTXA8X	9.22	Engine brake system	1	\$ 950.00	\$ 950.00
VHXZZX	9.23	Relocate air dryer		\$ 243.00	\$ -
K9XO9X	9.24	Extended life anti-freeze	1	\$ 126.00	\$ 126.00
UBXM1X	9.25	ENGINE MOUNTED HYDRAULIC PUMP PARKER F2-42/42		\$ 2,724.00	\$ -
UBXD1X	9.26	ENGINE MOUNTED HYDRAULIC PUMP PARKER F1-81		\$ 1,969.00	\$ -
UBXC1X	9.27	ENGINE MOUNTED HYDRAULIC PUMP PARKER F1-61		\$ 1,881.00	\$ -
T1XK1X	9.28	REAR ENGINE MOUNTED PTO WITH SPLINED SHAFT GROOVE FEMALE DIN 5462		\$ 349.00	\$ -
NCXD1X	9.29	VOLVO 12 V GEAR REDUCTION STARTER (MODEL 105P55)		\$ 92.00	\$ -
JWXE1X	9.30	HOOD MOUNTED AIR INTAKE WITH INSIDE/OUTSIDE AIR IN CAB CONTROL SNOW DOOR	0	\$ 173.00	\$ -
T1XA1X	9.31	REAR ENGINE POWER TAKE OFF WITH FLANGE SAE 1410		\$ 540.00	\$ -
NCXA5X	9.32	Starter motor options **DELCO REMY 12 39MTHD STARTER		\$ 98.00	\$ -
H9XK1X	9.33	1240 SQ IN RADIATOR 2 ROW CORE	1	\$ 225.00	\$ 225.00

heated

10.0 TRANSMISSION OPTIONS:

(After the first Six listed options, list manual and automatic transmission options. List make and model, # of speeds, type of shifting and whether or not transmission includes PTO gear(s) or not). Example: Allison 3000 HS, 5 speed, push button, no PTO.

NA	10.1	2 plate 14" ceramic clutch option for manual transmission		No Bid	
250090	10.2	2 plate 15½" ceramic clutch option for manual transmission		No Bid	
RBXA1A	10.3	External grease fitting for throw out bearing		\$ 103.00	\$ -
NA	10.4	Adjustment free option for 2 plate clutches	1	STD	
NA	10.5	Synthetic (TranSynd) lubrication for Automatic Transmission	1	\$ 145.00	\$ 145.00
Loc002	10.6	Stainless Steel Transmission cooler lines	1	\$ 1,950.00	\$ 1,950.00
NA	10.7	Synthetic lubrication for Manual Transmission	1	STD	
***** VOLVO AUTOMATED MANUAL TRANSMISSIONS					
270707	10.8	VOLVO I-SHIFT FOR SEVERE DUTY, AT2612F DIRECT DRIVE, 12 SPEED		\$ 2,344.00	\$ -
270708	110.9	VOLVO I-SHIFT FOR SEVERE DUTY, ATO2612F, 12 SPEED		\$ 2,344.00	\$ -
270711	10.10	VOLVO I-SHIFT WITH CRAWLER, ATO2612F, 13 SPEED		\$ 4,566.00	\$ -
270714	10.11	VOLVO I-SHIFT WITH ULTRA-LOW CRAWLER, ATO2612F, 14 SPEED		\$ 4,566.00	\$ -
***** MANUAL TRANSMISSIONS					
270721	10.12	EATON FULLER ADVANTAGE FAO15810C, 10 SPEED		\$ 989.00	\$ -

270722	10.13	EATON FULLER ADVANTAGE FAO16810C, 10 SPEED		\$ 1,103.00	\$ -
270733	10.17	EATON FULLER FRO-15210C, 10 SPEED		\$ (257.00)	\$ -
270734	10.18	EATON FULLER FRO-16210C, 10 SPEED		\$ 561.00	\$ -
270735	10.19	EATON FULLER FRO-17210C, 10 SPEED		\$ 899.00	\$ -
270737	10.21	EATON FULLER RTO-14908LL, 10 SPEED		\$ 1,262.00	\$ -
270738	10.22	EATON FULLER RTO-16908LL, 10 SPEED		\$ 1,358.00	\$ -
270739	10.23	EATON FULLER RTO-14909ALL, 11 SPEED		\$ 1,826.00	\$ -
270740	10.24	EATON FULLER RTO-16909ALL, 11 SPEED		\$ 1,928.00	\$ -
270743	10.25	EATON FULLER RTLO-16913A, 13 SPEED		\$ 1,239.00	\$ -
270744	10.26	EATON FULLER RTLO-18913A, 13 SPEED		\$ 1,755.00	\$ -
270747	10.27	EATON FULLER RTLO-16918B, 18 SPEED		\$ 1,826.00	\$ -
270748	10.28	EATON FULLER RTLO-18918B, 18 SPEED		\$ 1,826.00	\$ -

***** FULLY AUTOMATIC TRANSMISSIONS

270762	10.29	ALLISON 3000 RDS SERIES 5 SPEED WITH PTO PROVISION - SCAAN REQUIRED BEFORE ORDERING		\$3,113.00	\$ -
270765	10.30	ALLISON 4000 RDS SERIES 6 SPEED WITH PTO PROVISION - SCAAN REQUIRED BEFORE ORDERING		\$7,410.00	\$ -
270768	10.31	ALLISON 4500 RDS SERIES 5 SPEED WITH PTO PROVISION - SCAAN REQUIRED BEFORE ORDERING		\$7,586.00	\$ -
270769	10.32	ALLISON 4500 RDS SERIES 6 SPEED WITH PTO PROVISION - SCAAN REQUIRED BEFORE ORDERING	1	\$ 8,086.00	\$ 8,086.00
TKXB1X	10.34	UPGRADE DRIVELINE ONE SIZE		\$ 107.00	\$ -
TKXC1X	10.35	UPGRADE DRIVELINE TWO SIZES		\$ 127.00	\$ -
T4XAKX	10.36	REAR TRANSMISSION PTO, SAE 1310 FLANGE LOW SPEED		\$ 2,513.00	\$ -
T4XDMX	10.37	REAR TRANSMISSION PTO, DIN-CONNECTION PUMP MEDIUM SPEED		\$ 2,108.00	\$ -
T4XF1X	10.38	REAR TRANS PTO, HEAVY DUTY, SAE 1350 / 1410 FLANGE HIGH SPEED		\$ 2,053.00	\$ -
T4XH1X	10.39	REAR DOUBLE TRANS PTO, HEAVY DUTY, (1) SAE 1350 / 1410 FLANGE HIGH SPEED + (1) DIN-CONNECTION PUMP HIGH SPEED		\$ 2,399.00	\$ -
T4XJ1X	10.40	REAR TRIPLE TRANS PTO, HEAVY DUTY, (1) SAE 1310 FLANGE LOW SPEED + (1) SAE 1350/1410 FLANGE HIGH SPEED + (1) DIN-CONN. PUMP HIGH SPEED		\$ 3,184.00	\$ -
T4XG1X	10.41	REAR DOUBLE TRANS PTO, HEAVY DUTY, (2) DIN-CONN. PUMPS HIGH SPEED		\$ 1,864.00	\$ -
T4XD5X	10.42	TRANSMISSION PTO PREP ELECTRIC / AIR SOLENOID		\$ 25.00	\$ -
RVXH5X	10.43	GEAR SHIFT LEVER, PREMIUM, I-Shift		\$ 25.00	\$ -
RVXH4X	10.44	GEAR SHIFT LEVER, DASH MOUNTED, PREMIUM, VOLVO I-SHIFT		\$ 145.00	\$ -
INTER	10.45	Local Change to Allison Programming - Performance Mode		\$ 1,450.00	\$ -

11.0 ELECTRICAL OPTIONS:

NA	11.1	Resettable circuit breaker electrical protection		No Bid	
NA	11.2	Automatic reset circuit breakers		No Bid	
NA	11.3	Solid state circuit protection		No Bid	
L1XB1X	11.4	Circuit box under hood or end of frame, each		No Bid	
NFXD1X	11.5	Battery disconnect off negative side in cab control	0	\$ 10.00	\$ -
NZZD1X	11.6	Remote jump start terminals		\$ 345.00	\$ -
5RXA1X	11.7	Back up alarm (Preco Factory Model)	1	\$ 23.00	\$ 23.00
LSXG1X	11.8	OEM daytime running lights	1	STD	
NA	11.10	Battery box aft of cab		\$ 178.00	\$ -
NA	11.11	Grote 44710 flasher		No Bid	
NPXB1X	11.12	Signal Stat 935 turn signal per Spec 12.6	1	STD	
NZZACZ	11.13	Auxiliary customer access circuits	1	STD	
NJXAAX	11.14	Switch for snowplow lights mounted on instrumental panel. Includes wiring terminated near headlights, for customer mounted auxiliary snowplow lights.	1	\$ 78.00	\$ 78.00
NZZAAX	11.15	Power source terminal-2 stud type-mounted on firewall or inside cab with ground to frame rail and to starter, with 6 gauge wire.		\$ 76.00	\$ -
EAXABX	11.16	10-position switch panel mounted on instrument panel. Includes 10 lighted switches, ignition control; switches will control relays which will feed stud type junction block mounted inside cab.	1	\$ 663.00	\$ 663.00 5 switches available
NZZABZ	11.17	Vehicle speed sensor with speed signal at fuse panel for sander ground speed control system.	1	\$ 456.00	\$ 456.00

12.0 CAB EXTERIOR OPTIONS:

LZXD1X	12.2	Air horns, dual, round, with snow shields	0	\$ 165.00	\$ -
NA	12.3	Dual rectangular air horns	1	\$ 165.00	\$ 165.00
EDXB1X	12.4	Fender mirrors per Spec 12.4		\$ 68.00	\$ -
3GXB1X	12.5	Heated mirrors per Spec 12.5	1	\$ 99.00	\$ 99.00
NA	12.6	Remote control for R.H. mirror		No Bid	
3GXC1X	12.7	Remote control for dual mirrors	1	\$ 167.00	\$ 167.00
NA	12.8	Upcharge for cab extension or larger cab		No Bid	
NA	12.9	Severe duty aluminum cab option		No Bid	
9801S0	12.10	Dupont Highway orange paint or equal	1	\$ 249.00	\$ 249.00

2M (7)

955043	12.11	Premium paint color option		\$ 138.00	\$ -
955040	12.12	Imron paint option	1	STD	
955041	12.13	Imron and clear coat paint option		\$ 152.00	\$ -
9811C2	12.14	Top of hood painted flat black	0	\$ 467.00	\$ -
2DX30X	12.15	Cab Air Ride Suspension	1	STD	
28XC1X	12.16	Tilting hood per Spec 12.8		\$ 367.00	\$ -
NA	12.17	Butterfly option on hood		\$ 378.00	\$ -
NA	12.18	Transverse hood opening w/setback axle		No Bid	
NA	12.19	Front fender mounted turn signals		No Bid	
4NXZ1X	12.20	Cab visor, external, painted to match cab color	1	\$ 185.00	\$ 185.00
65XA1X	12.21	Front fender extensions	1	\$ 85.00	\$ 85.00
NA	12.22	Front fender mud flaps		\$ 22.00	\$ -
D2XB1X	12.23	Arctic winter wiper blades	1	\$ 17.00	\$ 17.00
NA	12.24	Optional windshield washer tank		No Bid	
20XB1X	12.25	Per truck charge for all trucks, key identical		\$ 25.00	\$ -
NA	12.26	RH observation prism window in door		No Bid	
NA	12.27	Spotlight LH, RH, or roof mounted each		No Bid	
4EXB1X	12.28	Front tow hooks		\$ 231.00	\$ -
6PXB1X	12.29	Rear tow hooks		\$ 85.00	\$ -
3FX49X	12.30	BLACK AERODYNAMIC EXTERIOR MIRRORS		\$ 146.00	\$ -
EDXB7X	12.31	Heated fender mirrors	1	\$ 446.00	\$ 446.00
WTXA1X	12.32	HEATED WINDSHIELD	1	\$ 210.00	\$ 210.00

include extension

8" only

13.0 CAB INTERIOR OPTIONS:

540068	13.1	Medium grade interior trim package		\$ 110.00	\$ -
540070	13.2	Premium grade interior trim package	1	\$ 150.00	\$ 150.00
NA	13.3	Round universal gauge package	1	STD	
2XX30X	13.4	Power window, passenger side		\$ 81.00	\$ -
2XX35X	13.5	Power window/both passenger and driver window	1	\$ 150.00	\$ 150.00
MC	13.6	O.E.M factory installed, AM/FM	1	STD	
NA	13.7	O.E.M factory installed, air conditioning **STANDARD	1	STD	
NA	13.8	Cab mounted non-resettable hour meter **STANDARD	1	STD	
571018	13.9	Dash mounted air cleaner air restriction gauge		\$ 78.00	\$ -
CCXB1X	13.10	Transmission temp gauges	1	\$ 79.00	\$ 79.00
NA	13.11	Windshield defroster fan w/switch dash mounted	1	STD	
NA	13.12	Between seats mounted console		\$ 16.00	\$ -
NA	13.13	Transmission oil sensor (check & fill)	1	STD	
5JXA1X	13.14	CB hot jacks dash mounted	1	\$ 26.00	\$ 26.00
2WXA1X	13.15	Tilt & telescope steering wheel		\$ 190.00	\$ -
2WZZ1X	13.16	Tilt steering wheel	1	STD	
2WXA1X	13.17	SRS DRIVER SIDE AIR BAG IN STEERING WHEEL	1	\$ 138.00	\$ 138.00
WPXA1X	13.18	TRACTION CONTROL ADDED TO ABS	1	\$ 138.00	\$ 138.00
	13.19	Self canceling turn signals	1	STD	

List seating options for driver and passenger seats. Use as many options as you need to offer seat variations customers have been buying.

*****INTERIOR TRIM LEVELS

540066	13.22	X1 WREN VINYL TRIM PACKAGE	0	STD	
540068	13.23	X2 Raven Cloth TRIM PACKAGE		\$120.00	\$ -
540067	13.24	X3 WREN CLOTH WITH MIGRATION PATTERN		\$120.00	\$ -
540070	13.25	X4 RAVEN MORDURA CLOTH		\$195.00	\$ -
540069	13.26	X5 WREN VINYL / WREN CLOTH	1	\$ 195.00	\$ 195.00
540072	13.27	X7 WREN LEATHER		\$345.00	\$ -
540071	13.28	X6 WREN LEATHER / WREN CLOTH WITH ORANGE ACCENT		\$195.00	\$ -
		SEAT MANUFACTURER			\$ -
35XD1X	13.29	NATIONAL SEAT	1	STD	
35XB1X	13.30	BOSTROM SEAT		\$ 50.00	\$ -
35XH1X	13.31	SEARS SEAT		\$ 55.00	\$ -
	13.32	DRIVER SEAT TYPE			\$ -
3YXF2X	13.33	AIR SUSPENSION HIGH BACK		\$ 35.00	\$ -
3YXG8X	13.34	COMFORT AIR SUSPENSION HIGH BACK	0	\$ 69.00	\$ -
3YXG9X	13.35	COMFORT AIR SUSPENSION HIGH BACK, HEATED		\$ 112.00	\$ -
3YXJ1X	13.36	COMFORT AIR SUSPENSION HIGH BACK WITH BACK CYCLER	1	\$ 25.00	\$ 25.00
		PASSENGER SEAT TYPE			\$ -
32X40X	13.38	STATIONARY BENCH SEAT WITH TOOL BOX	0	\$ 375.00	\$ -
32XF3X	13.39	AIR SUSPENSION HIGH BACK	0	\$ 148.00	\$ -
32XG8X	13.40	COMFORT AIR SUSPENSION HIGH BACK		\$ 214.00	\$ -
32XG9X	13.41	COMFORT AIR SUSPENSION HIGH BACK, HEATED		\$ 228.00	\$ -
32XJ1X	13.42	COMFORT AIR SUSPENSION HIGH BACK WITH BACK CYCLER		\$ 368.00	\$ -
32X99X	13.42	NO PASSENGER SEAT PROVIDED		\$ (58.00)	\$ -

stationary pass seat

		SEAT ARMREST			\$ -
3PXZ1X	13.43	NO SEAT ARMREST PROVIDED		\$ (5.00)	\$ -
3PXA1X	13.43	INBOARD DRIVER SEAT ARMREST		\$ 19.00	\$ -
3PXA5X	13.43	INBOARD / OUTBOARD DRIVER SEAT ARMREST	0	\$ 38.00	\$ -
3PXC1X	13.43	INBOARD DRIVER AND PASS SEAT ARMREST	0	\$ 38.00	\$ -
3PXC5X	13.43	INBOARD / OUTBOARD DRIVER AND PASSENGER SEAT ARMREST		\$ 76.00	\$ -
		SAFETY BELT LENGTH			\$ -
K7AA1X	13.44	STANDARD SAFETY BELT LENGTH	0	STD	
K7AC1X	13.45	EXTENDED SAFETY BELT LENGTH	1	\$ 50.00	\$ 50.00
		SAFETY BELT DRIVER SEAT			\$ -
OUXA1X	13.46	SAFETY BELT DRIVER SEAT, BLACK	0	STD	
OUXC1X	13.47	SAFETY BELT DRIVER SEAT, ORANGE	1	\$ 8.00	\$ 8.00
OUXD1X	13.48	SAFETY BELT DRIVER SEAT, LIME GREEN		\$ 10.00	\$ -
		SAFETY BELT PASSENGER SEAT			\$ -
OXXA1X	13.49	SAFETY BELT PASSENGER SEAT, BLACK	0	STD	
OXXA2X	13.50	SAFETY BELT PASSENGER SEAT, ORANGE	1	\$ 8.00	
OXXA7X	13.51	SAFETY BELT PASSENGER SEAT, LIME GREEN		\$ 10.00	

14.0 MN/DOT OPTIONS:

	14.1	Additional warranty coverage per spec 12.9			
M510Z1	14.2	Engine Plan 2 60 months 250,000 miles		\$ 2,910.00	\$ -
M51131	14.3	Engine Plan 2 72 months 250,000 miles		\$ 4,690.00	\$ -
M51141	14.4	Engine Plan 2 84 months 250,000 miles		\$ 6,270.00	\$ -
M511B1	14.5	Engine Plan 2 60 months 250,000 miles - HP over 460 horses		\$ 4,308.00	\$ -
M511F1	14.6	Engine Plan 2 72 months 250,000 miles - HP over 460 horses		\$ 6,961.00	\$ -
511G1	14.7	Engine Plan 2 84 months 250,000 miles - HP over 460 horses		\$ 9,414.00	\$ -
M53083	14.8	Engine after-treatment systems (EATS) 60 months 250,000 miles		\$ 942.00	\$ -
M530Y3	14.9	Engine after-treatment systems (EATS) 72 months 250,000 miles		\$ 1,708.00	\$ -
M531O3	14.10	Engine after-treatment systems (EATS) 84 months 250,000 miles		\$ 2,274.00	\$ -
M53083	14.11	Engine after-treatment systems (EATS) 60 months 250,000 miles - HP over 460 horses		\$ 1,566.00	\$ -
M530Y3	14.12	Engine after-treatment systems (EATS) 72 months 250,000 miles - HP over 460 horses		\$ 2,087.00	\$ -
M531O3	14.13	Engine after-treatment systems (EATS) 84 months 250,000 miles - HP over 460 horses		\$ 2,408.00	\$ -
M54174	14.14	iShift HD Transmission 48 months 500,000 miles		\$ 2,166.00	\$ -
M54184	14.15	iShift HD Transmission 60 months 500,000 miles		\$ 3,216.00	\$ -
N/A	14.15	Allison 60 month unlimited mileage Extended Warranty		\$ 1,312.00	\$ -
M560A6	14.16	HVAC (Air Conditioning) 60 months		\$ 840.00	\$ -
M59089	14.17	Starter 60 months 300,000 miles		\$ 282.00	\$ -
M60080	14.18	Alternator 60 months 300,000 miles		\$ 324.00	\$ -
M61071	14.19	Starter & Alternator 60 months 300,000 miles		\$ 438.00	\$ -
	14.20	Prebuild specification meeting (per person) to be held in St. Paul/Minneapolis area.		\$ 1.00	\$ -
	14.21	Pilot inspection meeting (per person).		\$ 2,250.00	\$ -

TRAILER TOW OPTIONS:

MC	15.1	Trailer tow package extended to rear of frame	0	\$ 636.00	\$ -
MC	15.2	Trailer package extend to rear of frame per Spec 12.12		\$ 947.00	\$ -

MANUALS / INTEREST FEE:

	16.0	Percent interest per month (non-compounding) on unpaid cab & chassis balance. Applies only to CPV Members. (Payable after trade-in is delivered to vendor). Percentage/per month.			\$ -
	16.1	SEE Exhibit C : Specifications re interest to State agencies.			
	16.2	Premium Tech Tool		\$ 4,000.00	\$ -

Delivery Charges:

	17.0	Price per loaded mile Starting Point			
	17.1	Roseville		\$ 2.50	\$ -

Maintenance/ Body Shop Labor rates

	18.0	Rate for Initial Inspection/Diagnostic		\$ 195.00	\$ -
	18.1	Rate for Mechanical Work		\$ 195.00	\$ -
	18.2	Rate for Body Work		\$ 195.00	\$ -

Quantity Discounts:

	19.0	Enter the number of units that must be purchased and the corresponding discount offered to the purchaser. More than one quantity discount may be entered.			\$ -
--	------	---	--	--	------

Next Model Year Upcharges

2M (9)

	20.0	Enter the following Production Model Year here >>>>>>>>		2026	
	20.1	Percentage Upcharge for the following Model Year Base Unit	1	3.00%	\$ 3,767.37
	20.2	Percentage Upcharge for the following Model Year Options	1	3.00%	\$ 967.74
	20.3	Rate for Body Work	1	\$ 3,500.00	\$ 3,500.00
	20.4	Enter the following Production Model Year here >>>>>>>>		2027	
	20.5	Percentage Upcharge for the following Model Year Base Unit	1	3.00%	\$ 3,767.37
	20.6	Percentage Upcharge for the following Model Year Options	1	3.00%	\$ 967.74

Total \$ 170,807.22



VERBAL/WRITTEN QUOTE SUMMARY SHEET

Minimum 2 verbal or written quotes required for items/services costing at least \$2,500 but less than \$9,999. Minimum 3 written quotes required for items/services costing at least \$10,000 but less than \$24,999.

No Quotes are required for items purchased through state cooperative purchasing venture.

Use this form to summarize quotes received and to select vendor for award.

Name: Mike Haaland Dept: Street Dept. Phone: 763 271 3277

Signature of Person Obtaining Quotes: Mike E. Haaland

Item/Service Requested: Plow Equipment / dump body

Budgeted Unbudgeted

Note: If you are unable to obtain required number of quotes, provide an explanation below in notes/comments.

#	Date	Vendor Name	Contact Person	Phone Number	Total \$ Amount Quoted
1	5 Sept 25	Towmaster	Josh Paulson	320 693 7900	\$212,342.00
2					
3					
4					

Selected Vendor: Towmaster

(If you are selecting other than low quote, you are required to provide written justification as to why low quote was not selected in the notes/comments section):

Notes/comments:

state contract pricing.

Approval Acknowledgement: _____ Date: _____

Attach this form and written quotes obtained to invoice. Questions may be directed to the Finance Department.



TOWMASTER, 61381 US HWY 12, LITCHFIELD, MN 55355
 PH: 320-693-7900 FX: 320-693-7921 TF: 800-462-4517
 TOWMASTERTRUCK.COM

Reference No.
 QT 98109

**** QUOTATION ****

Ship To: MONTICELLO, CITY OF 505 WALNUT STREET, SUITE 1 MONTICELLO MN 55362 USA	Cust: 3249 Phone:	Bill To: MONTICELLO, CITY OF 505 WALNUT STREET, SUITE 1 MONTICELLO MN 55362	Phone:
---	------------------------------------	---	---------------

ATTN: MATT BARTHEL

PO#	Salesman	Terms	Created	Last Revised	Appx Comp
	JOSH PAULSON	NET 30 DAYS	9/05/25	9/05/25	0/00/00

Serial No.	Qty	Part No.	Description	Price Ea.	Net Amt.
	1	9900140	- Body 14'6" EDGE-RS/CS-56-46-46 - - 56" 7ga Stainless Front w/CS hoist doghouse, 46" 7ga Stainless radius sides (no pockets), 46" 7ga Stainless w/Hardox 450 face Tailgate, 1/4" Hardox-450 Floor, 8" I-Beam Longsills, Air-trip ready linkage, Underside Black	\$27,078.00	\$27,078.00
	1	9901701	- Installation of Dump Body to hoist	\$2,420.00	\$2,420.00
	1	9900145	- Body acc'y TMTE Air trip kit, w/solenoid valve	\$505.00	\$505.00
	1	9901702	- Installation of air operated tailgate latch kit, with solenoid valve in hydraulic valve enclosure.	\$472.00	\$472.00
	1	9900147	- Body acc Box Vibrator - Cougar model DC3200	\$866.00	\$866.00
	1	9901703	- Installation of Box Vibrator, with solenoid located in hydraulic valve enclosure.	\$549.00	\$549.00
	1	9900149	- Body acc'y MUFLAPS, FRONT (of driver wheels) w/ brkts installed	\$621.00	\$621.00
	1	9906172	- Cabshield, 1/2 type Stationary Free-Standing style, for VERTICAL VALVE w/plain STAINLESS STEEL canopy, Hot-Dipped Galvanized Modular Channel support stand, Slotted Center Viewing Window, (2) shovel holders, & reservoir mounts, Installed.	\$4,805.00	\$4,805.00
	1	9900207	- Ladder Flip-A-Way Access ladder (STAINLESS STEEL) Including Grab Handle above, and Interior Step, ea, Installed SPECIFY LOCATION HERE: LH FRONT	\$731.00	\$731.00
	1	9900211	- Body acc'y Dual "split" sander manifolds in rear corner posts	\$550.00	\$550.00

--- Continued ---

Accepted by

Date

Matt L. Washburn

19 Sept 2025

Price:

Total Discounts:

Net Cost:

Freight

Total:



TOWMASTER, 61381 US HWY 12, LITCHFIELD, MN 55355
 PH: 320-693-7900 FX: 320-693-7921 TF: 800-462-4517
 TOWMASTERTRUCK.COM

Reference No.
 QT 98109

**** QUOTATION ****

Ship To: MONTICELLO, CITY OF 505 WALNUT STREET, SUITE 1 MONTICELLO MN 55362 USA	Cust: 3249 MN 55362	Phone: USA	Bill To: MONTICELLO, CITY OF 505 WALNUT STREET, SUITE 1 MONTICELLO MN 55362	Phone: MN 55362
---	---	--------------------------------------	---	---

ATTN: MATT BARTHEL

PO#	Salesman	Terms	Created	Last Revised	Appx Comp
	JOSH PAULSON	NET 30 DAYS	9/05/25	9/05/25	0/00/00

Serial No.

****NOTE: MOUNTED ON RH STROBE TUBE, FOR WING VIEWING USAGE, WIRED AS DEFAULT**

2	9904692 - Camera System option, 120 degree night vision CCD weather-proof HEATED camera, only GEN 5 6100		\$182.00	\$364.00
2	9904693 - Camera System option, Harness, 65' Waterproof GEN 5 6100		\$195.00	\$390.00
1	9904694 - INSTALLATION of Extra Camera, & Harness GEN 5 6100 **NOTE: MOUNTED ON LH REAR CORNER POST, FOR REVERSE VIEWING USAGE, WIRED TO QUE UP BY REVERSE SIGNAL.		\$235.00	\$235.00
1	1941405 - Camera Guard, SS, Bolt-On		\$43.00	\$43.00
1	9905501 - PreCise ARC Sensor Kit #1125402, Wired (No Display), for use w/existing RW Display or 6100 Display (Includes M8 cable)		\$766.00	\$766.00
1	9905502 - PreCise ARC Sensor Mount #1126929, only GEN 5 6100		\$80.00	\$80.00
1	9900296 - Pre-Wet Towmaster/Varitech LDS-TG150-EGF Tailgate mt System. 150 gal tank, SS mtg hardware, plumbing, & Electric Gravity Feed Valve system.		\$6,334.00	\$6,334.00
1	9902487 - Installation of TAILGATE pre-wet system (New Towmaster) TO BE OLD STYLE OVER THE TAILGATE MOUNTING		\$1,098.00	\$1,098.00
1	9900297 - Pre-Wet Towmaster/Varitech LDS-TMR-190-EGF Body Side Mt Sys for Elliptical body. (2) 95 gal tanks, mtg hardware, plumbing, Electric Gravity Feed valve		\$4,730.00	\$4,730.00
1	9902483 - Installation of TMR pre-wet system (New Towmaster Body) TO HAVE MANUAL VALVE TO SWITCH BETWEEN SPRAY BAR AND SPINNERS. TO		\$1,411.00	\$1,411.00

--- Continued ---

Accepted by

Mill E. Paulson

Date

19 Sept 2025

Price:

Total Discounts:

Net Cost:

Freight

Total:



TOWMASTER, 61381 US HWY 12, LITCHFIELD, MN 55355
 PH: 320-693-7900 FX: 320-693-7921 TF: 800-462-4517
 TOWMASTERTRUCK.COM

Reference No.
 QT 98109

**** QUOTATION ****

Ship To: MONTICELLO, CITY OF 505 WALNUT STREET, SUITE 1 MONTICELLO MN 55362 USA	Cust: 3249	Phone:	Bill To: MONTICELLO, CITY OF 505 WALNUT STREET, SUITE 1 MONTICELLO MN 55362	Phone:
---	-------------------	---------------	---	---------------

ATTN: MATT BARTHEL

PO#	Salesman	Terms	Created	Last Revised	Appx Comp
	JOSH PAULSON	NET 30 DAYS	9/05/25	9/05/25	0/00/00

Serial No.

HAVE MAIN HOSE RUN THROUGH FRAMELONG SILLS (SEE JOSH FOR QUESTIONS)

Qty	Part No.	Description	Price Ea.	Net Amt.
1	9905480	- Pre-Wet SS Prewet Distribution Pipe Thru Sander	\$660.00	\$660.00
1	9900317	- Hoist Towmaster/MAILHOT G4 130-5-3 DOUBLE ACTING	\$5,105.00	\$5,105.00
1	9901711	- Installation of Telescopic DOUBLE acting hoist	\$2,161.00	\$2,161.00
1	9900311	- Hoist TMTE 48" Stabilizer	\$2,615.00	\$2,615.00
1	9902503	- Installation of TMTE Stabilizer & Safety Props	\$743.00	\$743.00
1	9902924	- Scraper FALLS IB-10A 1" x 17" MB, w/single lift cylinder W/12" bolt-on extension (11' total), LESS CUTTING EDGES	\$10,186.00	\$10,186.00
1	9901705	- Installation of underbody fixed angle scraper w/single lift cylinder	\$3,887.00	\$3,887.00
1	9904232	- Scraper FORCE Electric pressure transmitter to read on LCD screen, installed	\$429.00	\$429.00
1	9900351	- Scraper FORCE reverse/Auto-Lift system, ADD-A-FOLD valve, installed	\$538.00	\$538.00
1	9902948	- Wing Falls RHSDL10A-HYDPB Primed LESS CUTTING EDGES	\$15,058.00	\$15,058.00
1	9900389	- Installation Falls SDL Series Wing - w/Dripless Bulkhead Couplers TO HAVE FULL CROSS BRACE FOR REAR WING BRACKET	\$7,060.00	\$7,060.00
1	9901431	- Wing Falls RL (REAR LIFT) up charge SDL WING	\$649.00	\$649.00
1	9904688	- Wing Falls POST-LESS Toe Lift in lieu of Std Front post/slide system		

--- Continued ---

Price:

Total Discounts:

Net Cost:

Freight

Total:

Accepted by

Date

Matt E. Hurd

19 Sept 2025



TOWMASTER, 61381 US HWY 12, LITCHFIELD, MN 55355
 PH: 320-693-7900 FX: 320-693-7921 TF: 800-462-4517
 TOWMASTERTRUCK.COM

Reference No.
 QT 98109

**** QUOTATION ****

Ship To:	Cust: 3249	Phone:	Bill To:	Phone:
MONTICELLO, CITY OF			MONTICELLO, CITY OF	
505 WALNUT STREET, SUITE 1			505 WALNUT STREET, SUITE 1	
MONTICELLO	MN 55362	USA	MONTICELLO	MN 55362

ATTN: MATT BARTHEL

PO#	Salesman	Terms	Created	Last Revised	Appx Comp
	JOSH PAULSON	NET 30 DAYS	9/05/25	9/05/25	0/00/00
Serial No.					

****NOTE: NO EXTRA CHARGE**

1	9900477 - Wing Falls Hwy Orange - Paint Moldboard		\$465.00	\$465.00
1	9900545 - Plow Hitch Falls Installation of (supplied) Multi-Coupler FOR PLOW STEER			
1	9900555 - Plow Hitch Falls 44XB2/STD/STD/SA/SPR-RET/HITCH		\$4,478.00	\$4,478.00
1	9900589 - Installation Falls Plow Hitch - 40 Series 3Line/STDBLKHD		\$2,626.00	\$2,626.00
1	9900625 - Plow Push Unit Falls 24/44 Series Std		\$1,312.00	\$1,312.00
1	9900637 - Plow Falls High Visibility Marker Set		\$161.00	\$161.00
1	9900639 - Plow Falls 1/2" x 12" Standard Rubber Belt Snow Deflector Kit - Installed		\$509.00	\$509.00
1	9900641 - Plow Falls Parking Stand - Screw Adj Style		\$391.00	\$391.00
1	9903074 - Plow Falls Poly PTE-1248/TRP-EDG/NOSHU/POLY-BLK Plow LESS CUTTING EDGES		\$13,509.00	\$13,509.00
1	9900757 - Hitch TMTE Heavy Duty plate assembly,		\$623.00	\$623.00
1	9901716 - Hitch Installation of Pup Hitch (weld in style) or Mn Dot Predrilled		\$1,253.00	\$1,253.00
NOTE: HITCH PLATE FACE TO BE LOCATED: _____ IN REFERENCE TO REAR TIRE FACE. ** TO HAVE 2 D-RINGS ON PULL PLATE FOR HOOKING UP CHAINS. FALLS TO HAVE FULL CROSS BRACE FOR REAR WING POST				
1	9900996 - Sander Falls 1ASD-6CDSS-6P-1D-2S-LM Salt Special 6", SS Unit, LH & RH Discharge, Dual Poly Spinner Ass'y, w/uni-		\$8,533.00	\$8,533.00

--- Continued ---

Accepted by Mel E. Harb-d Date 19 Sept 2025

Price:
 Total Discounts:
 Net Cost:
 Freight
 Total:



TOWMASTER, 61381 US HWY 12, LITCHFIELD, MN 55355
 PH: 320-693-7900 FX: 320-693-7921 TF: 800-462-4517
 TOWMASTERTRUCK.COM

Reference No.
 QT 98109

**** QUOTATION ****

Ship To:	Cust: 3249	Phone:	Bill To:	Phone:
MONTICELLO, CITY OF			MONTICELLO, CITY OF	
505 WALNUT STREET, SUITE 1			505 WALNUT STREET, SUITE 1	
MONTICELLO	MN 55362	USA	MONTICELLO	MN 55362

ATTN: MATT BARTHEL

PO#	Salesman	Terms	Created	Last Revised	Appx Comp
	JOSH PAULSON	NET 30 DAYS	9/05/25	9/05/25	0/00/00

Serial No.	Description	Price	Appx Comp
	directional reversible auger (includes 1 extra salt shield), complete		
1 9901724	- Sander Install dual spinner w/uni-directional reversible auger & dual manifolds RH & LH rear w/dripless couplers	\$3,227.00	\$3,227.00
1 1917108	- Sander Towmaster Stainless Steel (optional) salt shield	\$57.00	\$57.00
1 9900823	- Sander TMTE Exterior (removable) sander/tailgate spill plates, Stainless Steel	\$624.00	\$624.00
1 9900851	- Valve System, Force Add-A-Fold MCV-ISO Valve 9 Functions, INSTALLED HOIST, PLOW LIFT, PLOW STEER, WING TOE, WING HEEL, WING PUSH-BAR, SCRAPER, AUGERR/L, SPINNER R/L	\$17,211.00	\$17,211.00
1 9902497	- Control System Force ULTRA-4-6100 Commander control, Installed	\$15,961.00	\$15,961.00
1 9900882	- Reservoir TMTE 31 Gal Cabshield mt (stainless steel) w/intank filter for system, installed	\$4,267.00	\$4,267.00
1 9900891	- Pump Force TXV92 (5.6 ci) Pump, 280 HOT SHIFT PTO for Allison Trans, w/Elec shut down installed	\$8,811.00	\$8,811.00
1 9900893	- Valve Force Cable pull-off (for use w/telescopic hoist) installed	\$758.00	\$758.00
1 9900936	- Valve Force ADDER for VERTICAL valve enclosure in lieu of standard	\$623.00	\$623.00
1 9905504	- Valve Force integrated float control (assist) valve and switch system ("Blade-Saver") for PLOW	\$966.00	\$966.00

--- Continued ---

Accepted by

Matt E. Hatched

Date

19 Sept 2025

Price:

Total Discounts:

Net Cost:

Freight

Total:



TOWMASTER, 61381 US HWY 12, LITCHFIELD, MN 55355
 PH: 320-693-7900 FX: 320-693-7921 TF: 800-462-4517
 TOWMASTERTRUCK.COM

Reference No.
 QT 98109

**** QUOTATION ****

Ship To: MONTICELLO, CITY OF 505 WALNUT STREET, SUITE 1 MONTICELLO MN 55362 USA	Cust: 3249	Phone:	Bill To: MONTICELLO, CITY OF 505 WALNUT STREET, SUITE 1 MONTICELLO MN 55362	Phone:
---	-------------------	---------------	---	---------------

ATTN: MATT BARTHEL

PO#	Salesman	Terms	Created	Last Revised	Appx Comp
	JOSH PAULSON	NET 30 DAYS	9/05/25	9/05/25	0/00/00

Serial No.	Description	Price	Appx Comp
1 9900871	Switch TMTE BODY UP Installed (electric controls only)	\$288.00	\$288.00
1 9900884	Sensor Force Low oil indicator system, SLIM-LINE AND CABSHIELD MOUNTED w/light mounted in cab, installed	\$334.00	\$334.00
1 9900904	Valve 2-port 1/2" Multi-Hose coupler system installed FOR PLOW STEER	\$1,265.00	\$1,265.00
1	WARRANTY - TOWMASTER EXCLUSIVE WARRANTY: 5 yr Steel/Stainless Steel Body Structure; 5 yr Whelen LED Light Systems; 4 yr SwapLoader Hoists; 1 year Swenson Spreaders, 2 yr Hyd, FALLS Snow Equip, Tele/Scissor Hoists, and all other items.		

Price: \$212,342.00

Total Discounts:

Net Cost: \$212,342.00

Freight

Total: \$212,342.00

Accepted by

Matt E. Huel

Date

19 Sept 2025



VERBAL/WRITTEN QUOTE SUMMARY SHEET

Minimum 2 verbal or written quotes required for items/services costing at least \$2,500 but less than \$9,999. Minimum 3 written quotes required for items/services costing at least \$10,000 but less than \$24,999.

No Quotes are required for items purchased through state cooperative purchasing venture.

Use this form to summarize quotes received and to select vendor for award.

Name: Michael Haaland Dept: Street Dept Phone: 763 271 3277

Signature of Person Obtaining Quotes: M. Haaland

Item/Service Requested: Auto Greaser

Budgeted Unbudgeted

Note: If you are unable to obtain required number of quotes, provide an explanation below in notes/comments.

#	Date	Vendor Name	Contact Person	Phone Number	Total \$ Amount Quoted
1	31 Oct 25	Lubecore Avon MA	Jim Czajkowski	1 320 761 6532	\$10,350.00
2					
3					
4					

Selected Vendor: Lubecore, Avon MA

(If you are selecting other than low quote, you are required to provide written justification as to why low quote was not selected in the notes/comments section):

Notes/comments:

State Contract Pricing.

Approval Acknowledgement: _____ Date: _____

Attach this form and written quotes obtained to invoice. Questions may be directed to the Finance Department.

2M (19)

 Lubecore MN - Next Generation Automated Lubrication

City of Monticello - 2026 Plow truck Autolube

City of Monticello

909 Golf Course Rd, 1
Monticello, MN 55362
United States

Mike Haaland

mike.haaland@ci.monticello.mn.us
763-271-3277

Reference: 20251031-085507787

Quote created: October 31, 2025

Quote expires: January 29, 2026

Quote created by: James Czajkowski

Owner

jimc@lubecoremn.com

+13207616532

Comments from James Czajkowski

Installation at our Avon Mn shop.

Products & Services

Item & Description	Quantity	Unit Price	Total
<p>44 point Tandem axle Plow truck; Lubecore EP0 4kg Pneumatic pump with automatic Low level shutoff, stay clear Makrolon Reservoir with integrated pressure gauge and Timer. Brass metering manifolds, Brass injectors, Brass terminal in- serts, Nylon Line (with loom in wear areas). Installed and tested, ready for work. Power supply is 12v and consists of ignition power and ground. Pneumatic pump supply from the secondary tank with supplied Air protection kit. Quote based on State of Mn s863 contract data.</p>	1	\$10,350.00	\$10,350.00
One-time subtotal			\$10,350.00
Total			\$10,350.00

Purchase terms

Conditional Appraisal Value

VALUE SUBJECT TO NT&E TRADE TERMS AGREEMENT
 CONSULT WITH YOUR SALES REPRESENTATIVE FOR DETAILS
 ESTIMATED VALUE VALID FOR 30 DAYS FROM APPROVAL DATE

Appraisal Approval Date: 10/1/2025 11:05 AM

Customer Name	City Of Monticello Public Works
Sales Representative	Brad Schmidt
Store Location	Nuss Truck & Equipment - Mankato 53976 208th Ln Mankato, MN 56002
Contact Number(s)	507-327-9679 507-327-9679
Contact Email	bschmidt@nussgrp.com

Customer Unit Number	116
Unit Details	2012 Mack GU812
VIN/Serial	1M2AX11C7CM001427
Mileage	61,474
Estimated Value	\$48,000.00
Notes/Comments	



CONSTRUCTION
EQUIPMENT
TRUCKS

VOLVO



2N. Consideration of approving Change Order #1 in the amount of \$40,487.38 with OMG Midwest, Inc as part of the School Boulevard Intersection Improvements Project

Prepared by: Assistant City Engineer	Meeting Date: 2/9/2026	<input checked="" type="checkbox"/> Consent Agenda Item <input type="checkbox"/> Regular Agenda Item
Reviewed by: Public Works Director/City Engineer, Finance Director	Approved by: City Administrator	

ACTION REQUESTED

Motion to approve Change Order #1 in the amount of \$40,487.38 with OMG Midwest, Inc as part of the School Boulevard Intersection Improvements Project.

PREVIOUS COUNCIL ACTION

- July 10, 2023:** Council approved the preparation of a feasibility report for the School Boulevard Intersection Improvements Project and approved a contract with Hakanson Anderson to provide engineering in the amount of \$235,500.
- May 13, 2024:** Council approved the purchase of permanent and temporary easements for the Edmonson and School Boulevard Roundabout.
- July 8, 2024:** Council approved the submission of a Public Interest Finding with MnDOT for the School Boulevard Intersection Improvements Project.
- July 22, 2024:** Council approved the purchase of right-of-way for the School Boulevard Intersection Improvements Project.
- September 9, 2024:** Council approved restricting on-street parking on School Boulevard from Highway 25 to Country Lane.
- October 14, 2024:** Council approved the feasibility study and set public hearing for November 12, 2024.

Council approved an Advance Construction Agreement with MnDOT.
- November 12, 2024:** Council approved ordering the improvements for the School Boulevard Intersection Improvements Project.
- November 25, 2024:** Council approved plans, specifications, and authorization to bid for the School Boulevard Intersection Improvements Project.

January 13, 2025: Council approved accepting bids and awarding the contract to OMG Midwest, Inc. for the School Boulevard Intersection Improvements project in the amount of \$3,157,869.76.

May 27, 2025: Council approved an agreement with Xcel Energy for the relocation of a transmission line pole.

REFERENCE AND BACKGROUND

The City received grant funding to partially fund the construction of two roundabouts along School Boulevard: one at the Edmonson Avenue intersection and the other at the Cedar Street intersection. Both intersections were previously controlled by four-way stop signs, and the traffic analysis completed as part of The Pointes at Cedar Master Plan recommended roundabouts to improve safety and traffic efficiency.

During construction, it was determined that boulevard irrigation systems would be impacted due to adjustments in the curb line and placement of the new sidewalks and trails. While the original contract included a small allowance for irrigation repair, no record plans were available for the privately owned irrigation systems located within the boulevard. As a result, the necessary repairs were completed on a force account basis in accordance with MnDOT specifications. The attached change order provides a detailed list of the labor and materials needed to repair the damaged irrigation systems.

- I. **Budget Impact:** The 2025 budget included \$3,400,000 for this project, about \$3.1M of which has been spent. Even though it is a new year, the work was completed in 2025 and will be accrued back to that budget year. Project costs of \$1,485,000 will be reimbursed by federal grant funds, \$380,000 will be transferred from the Street Lighting Fund, and the remaining costs will be paid for out of the Capital Projects Fund.
- II. **Staff Workload Impact:** N/A
- III. **Comprehensive Plan Impact:** The Pointes at Cedar Master Plan is an adopted appendix to the Monticello 2040 Vision + Comprehensive Plan; the document calls for both roundabouts to improve safety and efficiency along the collector roadway of School Boulevard.

STAFF RECOMMENDED ACTION

City staff recommend approval of Change order #1 OMG Midwest, Inc as part of the School Boulevard Intersection Improvements Project

SUPPORTING DATA

- Change Order #1



STATE AID FOR LOCAL TRANSPORTATION
CHANGE ORDER

SP/SAP(s)	SP 222-105-003	MN Project No.:	STBG-CRP 8624 (295)	Change Order No.	1
-----------	----------------	-----------------	---------------------	------------------	---

Project Location	SCHOOL BOULEVARD, CITY OF MONTICELLO				
Local Agency	CITY OF MONTICELLO	Local Project No.	MO 305		
Contractor	OMG MIDWEST, INC	Contract No.			
Address/City/State/Zip	14475 QUIRAM DRIVE, ROGER MN 55373				
Total Change Order Amount \$	\$40,487.38				

Issue: No record plans were available for the irrigation systems in the boulevards. It was determined that the Contract needs to be revised in accordance with specification 1402.3 - Significant Changes to the Character of Work.

Resolution:

1. The Contractor will reconstruct the boulevard irrigation systems to conform to the new street, walks and trail alignments. The Contractor will also eliminate the irrigation system from spraying across the walks and trails.

Entitlement: Payment for this work will be on a Force Account basis as provided in MnDOT Specification 1904 as shown in attached Form 21659.

The Contract time will be modified as follows: *Contract time is increased by 4 working days.*

Estimate Of Cost: (Include any increases or decreases in contract items, any negotiated or force account items.)						
**Group/ funding Category	Item No.	Description	Unit	Unit Price	+ or - Quantity	+ or - Amount \$
	NA	RECONSTRUCT IRRIGATION IN BLVD	LS	\$40,487.38	+1	+\$40,487.38
Net Change this Change Order						+\$40,487.38

Project Engineer:	Digitally signed by Craig J. Jochum DN: cn=Craig J. Jochum, o=Hakanson Anderson, ou, email=craigj@haa-inc.com, c=US Date: 2025.12.12 15:04:00 -06'00'	Date:	12-12-25
Print Name:	CRAIG JOCHUM, HAKANSON ANDERSON, INC.	Phone:	763-852-0485
Contractor:	<i>Casey Wisness</i>	Date:	12-12-25
Print Name:	CASEY WISNESS, OMG MIDWEST, INC.	Phone:	612-490-0296
Signature:		Date:	
Print Name:	MATT LEONARD	Phone:	763-271-3271
Title and Agency:	PUBLIC WORKS DIRECTOR, CITY OF MONTICELLO		



STATE AID FOR LOCAL TRANSPORTATION
CHANGE ORDER

SP/SAP(s)	SP 222-105-003	MN Project No.:	STBG-CRP 8624 (295)	Change Order No.	1
-----------	----------------	-----------------	---------------------	------------------	---

DSAE Portion: The State of Minnesota is not a participant in this contract. Signature by the District State Aid Engineer is for FUNDING PURPOSES ONLY and for compliance with State and Federal Aid Rules/Policy. Eligibility does not guarantee funds will be available.

This work is eligible for: Federal Funding State Aid Funding Local Funds

District State Aid Engineer: _____ Date: _____

Contract Number: SP 222-105-003

Contractor/Sub: OMG MIDWEST / PETERSON CO.

Engineer: HAKANSON ANDERSON

Notes:

SEE ATTACHED SHEETS FOR AFFIDAVIT OF MATERIALS AND CALCULATIONS OF LABOR, MATERIAL, AND EQUIPMENT COSTS.

Labor					MATERIAL				EQUIPMENT RENTAL					
# Of Men	Position Title	Hours	Pay Rate	Amount	No.	Kind of Material	Rate	Amount	No.	Description	Total Hours	Rate	Amount	
	ALL LABOR SEE ATTACHED SHEETS			\$14,617.85		TOTAL SEE ATTACHED SHEETS		\$7,317.00	1	TRUCK 3500	106.40	\$24.00	\$2,553.60	
									2	TRUCK 1500	8.40	\$20.00	\$168.00	
									3	14 FOOT TRAILER	SEE ATTACHED SHEETS		\$720.00	
									4	TRENCHER	SEE ATTACHED SHEETS		\$800.00	
Total Regular Time				\$14,617.85	SUB-TOTAL				\$7,317.00					
Total Overtime					Plus 15%				\$1,097.55					
SUB-TOTAL (Taxable Wage)				\$14,617.85	TOTAL OF MATERIAL				\$8,414.55					
PLUS 62% OF Taxable Wage				\$9,063.07	INDEPENDENT TRUCKING BY INVOICE									
SUB-TOTAL				\$23,680.92						SUB-TOTAL				\$4,241.60
Other Labor - Related costs chargeable to this Supplemental Agreement/Work Order					SPECIALTY CONTRACTOR					TOTAL OF EQUIPMENT				\$4,241.60
Health and Welfare										Computation of Prime Contractor Allowance				
Pension Fund					1904(4) MISC. COMPENSATION					(A)<\$50K	@10%	\$3,680.67		
Other Fringe Benefits					Type: i.e. dump fees, permits, etc.					(B)>\$50K	@ 2%	\$0		
Travel										TOTAL ALLOWANCE (A + B)				\$3,680.67
Subsistence				\$469.64						Total of page 1				\$40,487.38
TOTAL OF LABOR				\$24,150.56	TOTAL MISC. COMP.					GRAND TOTAL				\$40,487.38

Submit completed Summary, with associated 2137 forms and invoices to Central Office with Final packet.

All copies must be signed by the Engineer, and the Contractor or their Authorized Agent.

Note: When material is billed on this sheet, receipted invoices must accompany same.

The above report includes only items chargeable to Change Order No.

1

Engineer: HAKANSON ANDERSON, INC

Contractor: OMG MIDWEST, INC

Casey Wisness

12-12-25

By: CRAIG JOCHUM

By: CASEY WISNESS

Peterson Companies

Irrigation Inventory By Job and Bin

7/11/2025 - 10/6/2025

Employee Name	Date	Job	Phase	Bin Number	Quantity
Severin, Brian	07/21/25	25033 School Blvd Imprvmnt - Monticello	160 Irrigation	2127 WIRE: 18/13 x500FT	350.00
Lehner, Alexander	07/25/25	25033 School Blvd Imprvmnt - Monticello	160 Irrigation	1"POLYPIPE 1"POLY PIPE BLACK	600.00
Lehner, Alexander	07/25/25	25033 School Blvd Imprvmnt - Monticello	160 Irrigation	9103 1" Barb x .75 FPT Endup	4.00
Lehner, Alexander	07/25/25	25033 School Blvd Imprvmnt - Monticello	160 Irrigation	9200 1" 316 Clamps	8.00
Lehner, Alexander	07/25/25	25033 School Blvd Imprvmnt - Monticello	160 Irrigation	9210 3/4 X 1/2 RISER	8.00
Lehner, Alexander	07/25/25	25033 School Blvd Imprvmnt - Monticello	160 Irrigation	9212 BLAZ SADDLE TEE 1"xFP	4.00
Krueger, Joel	08/07/25	25033 School Blvd Imprvmnt - Monticello	160 Irrigation	1"POLYPIPE 1"POLY PIPE BLACK	350.00
Krueger, Joel	08/07/25	25033 School Blvd Imprvmnt - Monticello	160 Irrigation	1.25"POLYPIPE 1.25" POLY PIPE BLACK	300.00
Lane, Dalton	08/07/25	25033 School Blvd Imprvmnt - Monticello	160 Irrigation	9000 Hunter PGP Ultra Head	15.00
Lane, Dalton	08/07/25	25033 School Blvd Imprvmnt - Monticello	160 Irrigation	9001 4" Pro Spray	31.00
Lane, Dalton	08/07/25	25033 School Blvd Imprvmnt - Monticello	160 Irrigation	9100 1" Poly Coupler	2.00
Lane, Dalton	08/07/25	25033 School Blvd Imprvmnt - Monticello	160 Irrigation	9104 1" Blazing Endup	4.00
Krueger, Joel	08/07/25	25033 School Blvd Imprvmnt - Monticello	160 Irrigation	9116 1.25" Coupler	1.00
Lane, Dalton	08/07/25	25033 School Blvd Imprvmnt - Monticello	160 Irrigation	9116 1.25" Coupler	1.00
Krueger, Joel	08/07/25	25033 School Blvd Imprvmnt - Monticello	160 Irrigation	9117 1.25" Poly 90	1.00
Lane, Dalton	08/07/25	25033 School Blvd Imprvmnt - Monticello	160 Irrigation	9118 1.25" Poly TEE	2.00
Lane, Dalton	08/07/25	25033 School Blvd Imprvmnt - Monticello	160 Irrigation	9119 1.25" x1" Poly Coupler	4.00
Krueger, Joel	08/07/25	25033 School Blvd Imprvmnt - Monticello	160 Irrigation	9167 DBYS	1.00
Lane, Dalton	08/07/25	25033 School Blvd Imprvmnt - Monticello	160 Irrigation	9200 1" 316 Clamps	16.00
Krueger, Joel	08/07/25	25033 School Blvd Imprvmnt - Monticello	160 Irrigation	9202 1.25" 410 Clamps	8.00
Lane, Dalton	08/07/25	25033 School Blvd Imprvmnt - Monticello	160 Irrigation	9202 1.25" 410 Clamps	32.00
Lane, Dalton	08/07/25	25033 School Blvd Imprvmnt - Monticello	160 Irrigation	9204 .5 Funny Pipe Elbow	31.00
Lane, Dalton	08/07/25	25033 School Blvd Imprvmnt - Monticello	160 Irrigation	9205 .75 Funny Pipe Elbow	15.00
Lane, Dalton	08/07/25	25033 School Blvd Imprvmnt - Monticello	160 Irrigation	9212 BLAZ SADDLE TEE 1"xFP	28.00
Lane, Dalton	08/07/25	25033 School Blvd Imprvmnt - Monticello	160 Irrigation	9213 BLAZ SADDLE 1.25"xSP for Poly Pipe	14.00
Lane, Dalton	08/07/25	25033 School Blvd Imprvmnt - Monticello	160 Irrigation	9227 MP 1000 90-210	8.00
Lane, Dalton	08/07/25	25033 School Blvd Imprvmnt - Monticello	160 Irrigation	9246 MP Left Strip	1.00
Lane, Dalton	08/07/25	25033 School Blvd Imprvmnt - Monticello	160 Irrigation	9247 MP Right Strip	1.00
Lane, Dalton	08/07/25	25033 School Blvd Imprvmnt - Monticello	160 Irrigation	9248 MP Side Strip	21.00
Lane, Dalton	08/07/25	25033 School Blvd Imprvmnt - Monticello	160 Irrigation	9301 IRRI FUNNY PIPE	100.00
Krueger, Joel	08/08/25	25033 School Blvd Imprvmnt - Monticello	160 Irrigation	1"POLYPIPE 1"POLY PIPE BLACK	250.00
Krueger, Joel	08/08/25	25033 School Blvd Imprvmnt - Monticello	160 Irrigation	1.25"POLYPIPE 1.25" POLY PIPE BLACK	30.00
Krueger, Joel	08/08/25	25033 School Blvd Imprvmnt - Monticello	160 Irrigation	2127 WIRE: 18/13 x500FT	30.00
Krueger, Joel	08/08/25	25033 School Blvd Imprvmnt - Monticello	160 Irrigation	9000 Hunter PGP Ultra Head	4.00
Krueger, Joel	08/08/25	25033 School Blvd Imprvmnt - Monticello	160 Irrigation	9002 4" Pro Spray 40 PSI	9.00
Krueger, Joel	08/08/25	25033 School Blvd Imprvmnt - Monticello	160 Irrigation	9100 1" Poly Coupler	6.00
Krueger, Joel	08/08/25	25033 School Blvd Imprvmnt - Monticello	160 Irrigation	9101 1" Poly 90 Elbow	1.00
Krueger, Joel	08/08/25	25033 School Blvd Imprvmnt - Monticello	160 Irrigation	9102 1" Poly TEE	1.00

Krueger, Joel	08/08/25	25033	School Blvd Imprvmnt - Monticello	160	Irrigation	9104 1" Blazing Endup	3.00
Krueger, Joel	08/08/25	25033	School Blvd Imprvmnt - Monticello	160	Irrigation	9116 1.25" Coupler	2.00
Krueger, Joel	08/08/25	25033	School Blvd Imprvmnt - Monticello	160	Irrigation	9168 Blazing Blue Wire Connectors	6.00
Krueger, Joel	08/08/25	25033	School Blvd Imprvmnt - Monticello	160	Irrigation	9200 1" 316 Clamps	26.00
Krueger, Joel	08/08/25	25033	School Blvd Imprvmnt - Monticello	160	Irrigation	9202 1.25" 410 Clamps	10.00
Krueger, Joel	08/08/25	25033	School Blvd Imprvmnt - Monticello	160	Irrigation	9204 .5 Funny Pipe Elbow	9.00
Krueger, Joel	08/08/25	25033	School Blvd Imprvmnt - Monticello	160	Irrigation	9205 .75 Funny Pipe Elbow	4.00
Krueger, Joel	08/08/25	25033	School Blvd Imprvmnt - Monticello	160	Irrigation	9212 BLAZ SADDLE TEE 1"xFP	8.00
Krueger, Joel	08/08/25	25033	School Blvd Imprvmnt - Monticello	160	Irrigation	9230 MP 2000 90-210	4.00
Krueger, Joel	08/08/25	25033	School Blvd Imprvmnt - Monticello	160	Irrigation	9233 MP 3000 90-210	6.00
Lehner, Alexander	08/20/25	25033	School Blvd Imprvmnt - Monticello	160	Irrigation	11005 Dura 10" Round	12.00
Lehner, Alexander	08/20/25	25033	School Blvd Imprvmnt - Monticello	160	Irrigation	4"PVCPIPE 4" PVC PIPE	30.00
Krueger, Joel	09/04/25	25033	School Blvd Imprvmnt - Monticello	160	Irrigation	1"POLYPIPE 1"POLY PIPE BLACK	200.00
Krueger, Joel	09/04/25	25033	School Blvd Imprvmnt - Monticello	160	Irrigation	10102 .75 PVC Coupler SxS	5.00
Krueger, Joel	09/04/25	25033	School Blvd Imprvmnt - Monticello	160	Irrigation	10103 1" PVC 90 Elbow	3.00
Krueger, Joel	09/04/25	25033	School Blvd Imprvmnt - Monticello	160	Irrigation	11001 Standard Dura Valve Box	2.00
Krueger, Joel	09/04/25	25033	School Blvd Imprvmnt - Monticello	160	Irrigation	11005 Dura 10" Round	2.00
Krueger, Joel	09/04/25	25033	School Blvd Imprvmnt - Monticello	160	Irrigation	2124 WIRE:18/7 X1000FT	10.00
Krueger, Joel	09/04/25	25033	School Blvd Imprvmnt - Monticello	160	Irrigation	9006 12" Pro Spray 40 PSI	6.00
Krueger, Joel	09/04/25	25033	School Blvd Imprvmnt - Monticello	160	Irrigation	9100 1" Poly Coupler	2.00
Krueger, Joel	09/04/25	25033	School Blvd Imprvmnt - Monticello	160	Irrigation	9101 1" Poly 90 Elbow	2.00
Krueger, Joel	09/04/25	25033	School Blvd Imprvmnt - Monticello	160	Irrigation	9102 1" Poly TEE	2.00
Krueger, Joel	09/04/25	25033	School Blvd Imprvmnt - Monticello	160	Irrigation	9200 1" 316 Clamps	24.00
Krueger, Joel	09/04/25	25033	School Blvd Imprvmnt - Monticello	160	Irrigation	9204 .5 Funny Pipe Elbow	6.00
Krueger, Joel	09/04/25	25033	School Blvd Imprvmnt - Monticello	160	Irrigation	9265 Hunter 1" Drip Zone Kit 40 PSI	2.00
Krueger, Joel	09/04/25	25033	School Blvd Imprvmnt - Monticello	160	Irrigation	9267 Hunter 1" Valve SxS	1.00
Krueger, Joel	09/09/25	25033	School Blvd Imprvmnt - Monticello	160	Irrigation	1"POLYPIPE 1"POLY PIPE BLACK	800.00
Krueger, Joel	09/09/25	25033	School Blvd Imprvmnt - Monticello	160	Irrigation	10002 Standard Carson Deep Valve Box	1.00
Krueger, Joel	09/09/25	25033	School Blvd Imprvmnt - Monticello	160	Irrigation	10102 .75 PVC Coupler SxS	6.00
Krueger, Joel	09/09/25	25033	School Blvd Imprvmnt - Monticello	160	Irrigation	10103 1" PVC 90 Elbow	4.00
Krueger, Joel	09/09/25	25033	School Blvd Imprvmnt - Monticello	160	Irrigation	10104 1" PVC Cross	1.00
Krueger, Joel	09/09/25	25033	School Blvd Imprvmnt - Monticello	160	Irrigation	10106 1" PVC MPTx 1" SPG	3.00
Krueger, Joel	09/09/25	25033	School Blvd Imprvmnt - Monticello	160	Irrigation	9006 12" Pro Spray 40 PSI	6.00
Krueger, Joel	09/09/25	25033	School Blvd Imprvmnt - Monticello	160	Irrigation	9100 1" Poly Coupler	8.00
Krueger, Joel	09/09/25	25033	School Blvd Imprvmnt - Monticello	160	Irrigation	9101 1" Poly 90 Elbow	2.00
Krueger, Joel	09/09/25	25033	School Blvd Imprvmnt - Monticello	160	Irrigation	9102 1" Poly TEE	3.00
Krueger, Joel	09/09/25	25033	School Blvd Imprvmnt - Monticello	160	Irrigation	9103 1" Barb x .75 FPT Endup	1.00
Krueger, Joel	09/09/25	25033	School Blvd Imprvmnt - Monticello	160	Irrigation	9104 1" Blazing Endup	4.00
Krueger, Joel	09/09/25	25033	School Blvd Imprvmnt - Monticello	160	Irrigation	9125 Funny to Dripline	15.00
Krueger, Joel	09/09/25	25033	School Blvd Imprvmnt - Monticello	160	Irrigation	9200 1" 316 Clamps	64.00
Krueger, Joel	09/09/25	25033	School Blvd Imprvmnt - Monticello	160	Irrigation	9204 .5 Funny Pipe Elbow	6.00
Krueger, Joel	09/09/25	25033	School Blvd Imprvmnt - Monticello	160	Irrigation	9210 3/4 X 1/2 RISER	1.00
Krueger, Joel	09/09/25	25033	School Blvd Imprvmnt - Monticello	160	Irrigation	9212 BLAZ SADDLE TEE 1"xFP	18.00
Krueger, Joel	09/09/25	25033	School Blvd Imprvmnt - Monticello	160	Irrigation	9215 Drip Line TEE	15.00
Krueger, Joel	09/09/25	25033	School Blvd Imprvmnt - Monticello	160	Irrigation	9225 RainBird Drip Stack	4.00
Krueger, Joel	09/09/25	25033	School Blvd Imprvmnt - Monticello	160	Irrigation	9245 MP 3500 90-210	12.00
Krueger, Joel	09/09/25	25033	School Blvd Imprvmnt - Monticello	160	Irrigation	9265 Hunter 1" Drip Zone Kit 40 PSI	2.00

Krueger, 2N (7)
Krueger, Joel
Krueger, Joel

09/09/25 25033 | School Blvd Imprvmt - Monticello
09/09/25 25033 | School Blvd Imprvmt - Monticello
09/09/25 25033 | School Blvd Imprvmt - Monticello

Irrigation
160 | Irrigation
160 | Irrigation

9267 | Hunter 1" Valve SxS
9301 | IRRI FUNNY PIPE
9302 | Drip Line 18"

75.00
250.00

20. Consideration of approving Resolution 2026-05 supporting Wright County’s Pavement Preservation Project on CSAH 39

Prepared by: Public Works Director/City Engineer	Meeting Date: 2/9/2026	<input checked="" type="checkbox"/> Consent Agenda Item <input type="checkbox"/> Regular Agenda Item
Reviewed by: Finance Director	Approved by: City Administrator	

ACTION REQUESTED

Motion to approve Resolution 2026-05 supporting Wright County’s Pavement Preservation Project on CSAH 39

REFERENCE AND BACKGROUND

Wright County has a pavement preservation project planned for CSAH 39 in 2026. Portions of the project fall within the city limits and include a mill and overlay of Elm Street between Broadway Street and Golf Course Road, as well as Golf Course Road from 7th Street west to CSAH 8. The project will extend the service life of the roadway, improve the driving surface, and enhance the overall safety for motorists. Construction is anticipated to take approximately one month and is planned for completion this summer.

- I. **Budget Impact:** No local cost participation is expected for the project.
- II. **Staff Workload Impact:** Staff will coordinate with Wright County throughout the project.
- III. **Comprehensive Plan Impact:** The project supports Chapter 8 – Community Facilities and Infrastructure, which identifies the need for ongoing investment in public infrastructure systems—specifically calling for responsible maintenance and lifecycle management of streets and municipal assets as well as continuing support of critical partnerships with other agencies.

STAFF RECOMMENDED ACTION

City staff recommend approving Resolution 2026-05 supporting Wright County’s project.

SUPPORTING DATA

- Resolution 2026-05

**CITY OF MONTICELLO
WRIGHT COUNTY, MINNESOTA**

RESOLUTION NO. 2026-05

**RESOLUTION SUPPORTING THE WRIGHT COUNTY
PAVEMENT PRESERVATION PROJECT ON CSAH 39**

WHEREAS, the City of Monticello recognizes that a safe and well-maintained transportation network is vital to the economic health and safety of the community; and

WHEREAS, CSAH 39 locate within the corporate limits of the City, is a County Highway under the jurisdiction of Wright County; and

WHEREAS, the Wright County Highway Department has identified a need for pavement preservation to extend the service life of the roadway and improve the driving surface; and

WHEREAS, The City of Monticello desires to cooperate with Wright County to ensure the successful completion of this project with minimal disruption to local residents and businesses; and

WHEREAS, the City Council finds that this project aligns with the City's long-term infrastructure goals and enhances the overall safety for motorists, cyclists, and pedestrians.

NOW THEREFORE, BE IT RESOLVED BY THE CITY OF MONTICELLO, MINNESOTA as follows:

- 1) **Support for Project:** The City of Monticello hereby formally expresses its full support for the 2026 Pavement Preservation Project on CSAH 39 as proposed by Wright County.
- 2) **Collaboration:** City staff are authorized to coordinate with County officials regarding traffic control, public notifications, and any necessary local permitting to facilitate a seamless workflow.
- 3) **Future Maintenance:** The City acknowledges that this resolution does not alter existing maintenance agreements or jurisdictional boundaries unless specifically outlined in a separate agreement.
- 4) **Effective Date:** This resolution shall become effective immediately upon its passage and approval.

ADOPTED BY the Monticello City Council this 9th day of February, 2026.

CITY OF MONTICELLO

ATTEST:

Lloyd Hilgart, Mayor

Jennifer Schreiber, City Clerk

4A. Consideration of adopting Resolution 2026-06 Advancing Municipal State Aid funds in the amount of \$2,255,717.92

Prepared by: Public Works Director/City Engineer	Meeting Date: 2/9/2026	<input checked="" type="checkbox"/> Consent Agenda Item <input type="checkbox"/> Regular Agenda Item
Reviewed by: Finance Director	Approved by: City Administrator	

ACTION REQUESTED

Motion to adopt Resolution 2026-06 Advancing Municipal State Aid funds in the amount of \$2,255,717.92

PREVIOUS COUNCIL ACTION

January 23, 2023: Council approved advancing \$1,991,167.15 in Municipal State Aid funds.

REFERENCE AND BACKGROUND

Any municipality eligible to receive State Aid funding may advance or “borrow” State Aid construction funds up to four times its annual construction allotment from its State Aid account. For 2026, the City received a total of \$1,006,255 in State Aid funding, which includes \$251,564 for maintenance, used to help support street department operations, and \$754,691 for construction. Based on this construction allotment, the City is eligible to advance up to \$3,018,764.

The City previously advanced State Aid funds in 2023, and \$549,944.11 of those funds received remain outstanding. After accounting for this amount, \$2,468,819.89 is available for advancement.

To be eligible to receive reimbursement for state aid construction funds, projects must be located on a designated State Aid route, reviewed, and approved by MnDOT to ensure compliance with all State Aid requirements. Several past projects that were completed have unused balances totaling \$2,255,717.92 as outlined below:

State-Aid Project Number	Project Location	Advance Amount
222-104-002	Fallon Avenue	\$664,715.03
222-010-005	I-94 Ramp	\$446,508.23

222-101-007	7th Street	\$499,070.65
222-101-008	7th Street	\$17,000.78
222-101-006	7th Street	\$4,089.25
222-010-003	Broadway Street	\$254,976.15
222-105-001	Hwy 25	\$58,262.89
222-112-001	West River Street	\$17,740.10
222-112-002	East River Street	\$15,927.28
222-113-001	Washington Street	\$2,579.07
222-121-001	Palm Street	\$2,345.54
222-105-002	School Boulevard	\$272,502.95

While \$2,468,819.89 is available for advancement, the full amount cannot be utilized due to the lack of State Aid eligible projects at this time. The portion of the School Boulevard Intersection Improvements Project that was not funded by grant funds will be eligible for State Aid advancement once that project is accepted and approved by MnDOT.

- I. **Budget Impact:** If the request for advancement is approved by the State, \$2,255,717.92 will be distributed into the Transportation Improvement Fund to provide funding for the 2026 Street Improvement Project.
- II. **Staff Workload Impact:** N/A
- III. **Comprehensive Plan Impact:** N/A

STAFF RECOMMENDED ACTION

City staff recommend adopting Resolution 2026-06 advancing State Aid funds. This funding source is critical to local transportation projects.

SUPPORTING DATA

- Resolution 2026-06

**CITY OF MONTICELLO
WRIGHT COUNTY, MINNESOTA**

RESOLUTION NO. 2026-06

RESOLUTION ON MUNICIPAL STATE AID PROJECTS IN 2026

WHEREAS, the Municipality of Monticello is planning to implement Municipal State Aid Projects in 2026 which will require State Aid funds in excess of those available in its State Aid Construction Account; and

WHEREAS, the Municipality of Monticello is prepared to proceed with the construction of said projects through the use of an advance from the Municipal State Aid Street Fund to supplement the available funds in their State Aid Construction Account; and

WHEREAS, the advance is based on the following determination of estimated expenditures:

Account Balance as of date 2/2/26	\$ (549,944.11)
Less estimated disbursements:	
Project #222-104-002	\$ 664,715.03
Project #222-010-005	\$ 446,508.23
Project #222-101-007	\$ 499,070.65
Project #222-101-008	\$ 17,000.78
Project #222-101-006	\$ 4,089.25
Project #222-010-003	\$ 254,976.15
Project #222-105-001	\$ 58,262.89
Project #222-112-001	\$ 17,740.10
Project #222-112-002	\$ 15,927.28
Project #222-113-001	\$ 2,579.07
Project #222-121-001	\$ 2,345.54
Project #222-105-002	\$ 272,502.95
Bond Principle (if any)	\$ _____
Project Finals (overruns-if any)	\$ _____
Other _____	\$ _____
Total Estimated Disbursements	\$ 2,255,717.92
Advance Amount (amount in excess of acct balance)	\$ 2,805,662.03

WHEREAS, repayment of the funds so advanced will be made in accordance with the provisions of Minnesota Statutes 162.14, Subd. 6 and Minnesota Rules, Chapter 8820.1500, Subd. 10b; and

WHEREAS, the Municipality of Monticello acknowledges advance funds are released on a first-come-first-serve basis and this resolution does not guarantee the availability of funds.

**CITY OF MONTICELLO
WRIGHT COUNTY, MINNESOTA**

RESOLUTION NO. 2026-06

NOW THEREFORE, BE IT RESOLVED: That the Commissioner of Transportation be and is hereby requested to approve this advance for financing approved Municipal State Aid Street Projects of the Municipality of Monticello in an amount up to \$2,805,662.60. I hereby authorize repayments from subsequent accruals to the Municipal State Aid Street Construction Account of the Municipality of Monticello from future year allocations until fully repaid.

ADOPTED BY the Monticello City Council this 9th day of February, 2026.

CITY OF MONTICELLO

ATTEST:

Lloyd Hilgart, Mayor

Jennifer Schreiber, City Clerk

I HEREBY CERTIFY that the above is a true and correct copy of a resolution presented to and adopted by the Municipality of Monticello, County of Wright, State of Minnesota, at a duly authorized Municipal Council Meeting held in the Municipality of Monticello, Minnesota on the 9th day of February, 2026, as disclosed by the records of said Municipality on file and of record in the office.

Municipality of Monticello

Municipal Clerk

4B. Consideration of adopting Resolution 2026-07 approving MnDOT Cooperative Construction and Maintenance Agreement for TH 25 Bridge as related to I-94 Redecking Project

Prepared by: Public Works Director/City Engineer	Meeting Date: 2/9/2026	<input type="checkbox"/> Consent Agenda Item <input checked="" type="checkbox"/> Regular Agenda Item
Reviewed by: Finance Director	Approved by: City Administrator	

ACTION REQUESTED

Motion to adopt Resolution 2026-07 approve MnDOT Cooperative Construction Agreement No. 1061836 for ongoing maintenance and responsibilities related to the TH 25 Bridge (Bridge No. 86803) reconstruction project.

REFERENCE AND BACKGROUND

MnDOT plans to construct a project on Trunk Highway 25 (TH 25) at Bridge No. 86803 over I-94 in 2027. The project includes bridge redecking, bituminous surfacing, approach panels, sidewalk improvements, lighting replacement, and aesthetic enhancements.

As part of the project, MnDOT has requested that the City of Monticello assume long-term ownership and maintenance responsibilities for several components once construction is completed.

1. Sidewalk System Maintenance: The City will maintain all sidewalk elements over Bridge No. 86803, including:
 - Snow and ice removal
 - Debris removal
 - Crack repair and patching
 - Pedestrian ramp upkeep
 - Grass boulevard mowing
2. Lighting System Ownership & Maintenance: The City will own and maintain the aesthetic bridge lighting system with responsibilities including:
 - LED relamping and replacement
 - Pole and luminaire repairs
 - Electrical cabinet and distribution maintenance
 - Conduit repairs and wiring replacement
 - Utility locates

- Payment of all electrical service costs for the system
 - Aesthetic Feature Maintenance
3. Aesthetic Feature Maintenance: MnDOT will add cast-in-place “Monticello” lettering on the west barrier as well as swan emblems on ornamental railing panels. The City will maintain the new features, including:
- Painting
 - Graffiti removal
 - Replacement of emblems
 - Any repairs required to keep aesthetic elements in an acceptable condition

These responsibilities are consistent with updated standard MnDOT cooperative agreements when cities request enhanced aesthetics or pedestrian accommodations.

- I. **Budget Impact:** There is no local match expected for the project. Ongoing operation and maintenance costs are estimated to be around \$15,000 annually, which would be paid from a combination of the Street Lighting Improvement Fund and General Fund.
- II. **Staff Workload Impact:** The existing sidewalk over the bridge is maintained by MnDOT, including snow removal. The updated agreement will shift responsibility to City crews. The other maintenance agreement components noted will also be added responsibilities, though likely less frequently impacting workload.
- III. **Comprehensive Plan Impact:** Chapter 4, Mobility and Connectivity, supports improvements like redecking the Hwy 25 bridge over I-94 emphasizing safe, efficient transportation infrastructure that maintains regional mobility and enhances long-term corridor performance. Chapter 7, Community Character, Design, and the Arts, encourages aesthetic enhancements to public infrastructure, meaning that incorporating visual design features on the bridge aligns with the city’s goals to strengthen community identity and create attractive gateways.

STAFF RECOMMENDED ACTION

City staff recommend approving the Cooperative Construction and Maintenance Agreement with MnDOT.

SUPPORTING DATA

- Cooperative Maintenance and Construction Agreement and Resolution 2026-07

**STATE OF MINNESOTA
DEPARTMENT OF TRANSPORTATION
And
CITY OF MONTICELLO
COOPERATIVE CONSTRUCTION
AGREEMENT**

State Project Number (SP): 8605-58
Trunk Highway Number (TH): 25=025
Federal Project Number: BFP 8626(168)
Lighting System Feed Point No.: City – “C1”

This Agreement is between the State of Minnesota, acting through its Commissioner of Transportation ("State") and the City of Monticello acting through its City Council ("City").

Recitals

1. The State will perform Bridge No. 86803 redecking and repairs, grading, bituminous surfacing, approach panels, sidewalks, and lighting construction and other associated construction upon, along, and adjacent to Trunk Highway No. 25 from Reference Point 67+01.085 to 68+00.092 over I-94 according to State-prepared plans, specifications, and special provisions designated by the State as State Project No. 8605-58 (TH 25=025) ("Project"); and
2. The State has included in its contract an aesthetic lighting system on the barriers of Bridge No. 86803 and the City is willing to maintain the lighting system after completion of the construction. The City will also continue to own and maintain the other two light units south of the bridge from this lighting system that aren't being replaced; and
3. The State has included in its contract bridge aesthetic features such as cast-in-place lettering "Monticello" (community entrance sign) on the outside of the west facing barrier and swan features in the bridge ornamental railing on top of the barriers, and the City is willing to maintain these aesthetic features after completion of the construction; and
4. The City will assume maintenance responsibilities for the sidewalk system over Bridge No. 86803; and
5. Minnesota Statutes § 161.20, subdivision 2 authorizes the Commissioner of Transportation to make arrangements with and cooperate with any governmental authority for the purposes of constructing, maintaining, and improving the trunk highway system.

Agreement

1. Term of Agreement; Survival of Terms; Plans; Incorporation of Exhibits

- 1.1. Effective Date.** This Agreement will be effective on the date the State obtains all signatures required by Minnesota Statutes § 16C.05, subdivision 2.
- 1.2. Expiration Date.** This Agreement will expire when all obligations have been satisfactorily fulfilled.
- 1.3. Survival of Terms.** All clauses which impose obligations continuing in their nature and which must survive in order to give effect to their meaning will survive the expiration or termination of this Agreement, including, without limitation, the following clauses: 3. Maintenance by the City; 6. Liability; Worker Compensation Claims; Insurance; 8. State Audits; 9. Government Data Practices; 10. Governing Law; Jurisdiction; Venue; and 12. Force Majeure.

- 1.4. Plans, Specifications, and Special Provisions.** Plans, specifications, and special provisions designated by the State as State Project No. 8605-58 (TH 25=025) are on file in the office of the Commissioner of Transportation at St. Paul, Minnesota, and incorporated into this Agreement by reference ("Project Plans").
- 1.5. Exhibits.** Exhibit "A" – Lighting, Exhibit "B" – Concrete Barrier Emblem, and Exhibit "C" – Metal Railing Swan Emblem are attached and incorporated into this agreement.

2. Construction by the State

- 2.1. Contract Award.** The State will advertise for bids and award a construction contract to the lowest responsible bidder according to the Project Plans.
- 2.2. Direction, Supervision, and Inspection of Construction.**
- A. Supervision and Inspection by the State.** The State will direct and supervise all construction activities performed under the construction contract, and perform all construction engineering and inspection functions in connection with the contract construction. All contract construction will be performed according to the Project Plans.
- B. Inspection by the City.** The construction covered under this Agreement will be open to inspection by the City. If the City believes the construction covered under this Agreement has not been properly performed or that the construction is defective, the City will inform the State District Engineer's authorized representative in writing of those defects. Any recommendations made by the City are not binding on the State. The State will have the exclusive right to determine whether the State's contractor has satisfactorily performed the construction covered under this Agreement.
- 2.3. Plan Changes, Additional Construction, Etc.**
- A.** The State will make changes in the Project Plans and contract construction and will enter into any necessary addenda and change orders with the State's contractor that are necessary to cause the contract construction to be performed and completed in a satisfactory manner.
- B.** The City may request additional work or changes to the work in the plans as part of the construction contract. Such request will be made by an exchange of letter(s) with the State. If the State determines that the requested additional work or plan changes are necessary or desirable and can be accommodated without undue disruption to the project, the State will cause the additional work or plan changes to be made. The State reserves the right to invoice the City for the cost of any construction contract addenda and any additional City requested work and plan changes, including associated construction engineering, before the completion of the contract construction.
- 2.4. Satisfactory Completion of Contract.** The State will perform all other acts and functions necessary to cause the construction contract to be completed in a satisfactory manner. Acceptance by the State of the completed contract construction will be final, binding, and conclusive upon the City as to the satisfactory completion of the contract construction.
- 2.5. Permits.** The City will submit to the State's Utility Engineer an original permit application for all utilities owned by the City to be constructed hereunder that are upon and within the Trunk Highway Right-of-Way. Applications for permits will be made on State form "Application For Utility Permit On Trunk Highway Right-of-Way" (Form 2525).

3. Maintenance by the City

Upon completion of the project, the City will provide the following without cost or expense to the State:

- 3.1. Sidewalks.** Maintenance of any sidewalk construction, including stamped and colored concrete sidewalk (if any) and pedestrian ramps. Maintenance includes, but is not limited to, snow, ice, and debris removal, patching, crack repair, removing trip hazards (other than panel replacement), cross street pedestrian crosswalk markings, mowing grass boulevards (if any), and any other maintenance activities necessary to perpetuate the sidewalks in a safe, useable, and aesthetically acceptable condition.
- 3.2. Lighting.** Maintenance and ownership of the lighting facility shown in Exhibit "A" – Lighting construction. Maintenance of electrical lighting systems includes everything within the system, from the point of attachment to the power source or utility, to the last light on the feed point, including but not limited to re-lamping of lighting units or replacing of LED luminaires, repair or replacement of all damaged luminaire glassware, loose connections, luminaires when damaged or when ballasts fail, photoelectric control on luminaires, defective starter boards or drivers, damaged fuse holders, blown fuses, knocked down poles including wiring within the poles, damaged poles, pull boxes, underground wire, damaged foundations, equipment pad, installation of approved splices or replacement of wires, repair or extending of conduit, lighting cabinet maintenance including photoelectric cell, electrical distribution system, Gopher State One Call (GSOC) locates, and painting of poles and other equipment. The City will be responsible for the hook up cost and application to secure an adequate power supply to the service pad or pole and will pay all monthly electrical service expenses necessary to operate the lighting facility.
- 3.3. Bridge No. 86803 Aesthetics.** The City will perform maintenance and repair of aesthetic elements on Bridge No. 86803; this includes cast-in-place lettering "Monticello" (community entrance sign) on the outside of the west facing barrier shown in Exhibit "B" – Concrete Barrier Emblem, and swan features in the bridge ornamental railing on top of the barriers shown in Exhibit "C" – Metal Railing Swan Emblem. Maintenance and repair includes, but is not limited to, painting, graffiti removal, emblem replacement, and any other maintenance activities necessary to perpetuate the aesthetic elements in a safe, usable, and aesthetically acceptable condition.

4. Authorized Representatives

Each party's Authorized Representative is responsible for administering this Agreement and is authorized to give and receive any notice or demand required or permitted by this Agreement.

4.1. The State's Authorized Representative will be:

Name, Title: Jamie Hukriede, Assistant District Engineer - Maintenance (or successor)
 Address: 7694 Industrial Park Road, Baxter, MN 56425
 Telephone: 218-828-5700
 Fax: 218-828-5814
 E-Mail: jamie.hukriede@state.mn.us

4.2. The City's Authorized Representative will be:

Name, Title: Matt Leonard, Public Works Director/City Engineer (or successor)
 Address: 505 Walnut Street, Suite 1, Monticello, MN 55362
 Telephone: 763-271-3271
 E-Mail: Matt.Leonard@MonticelloMN.gov

5. Assignment; Amendments; Waiver; Contract Complete

- 5.1. Assignment.** No party may assign or transfer any rights or obligations under this Agreement without the prior consent of the other party and a written assignment agreement, executed and approved by the same parties who executed and approved this Agreement, or their successors in office. The foregoing does not

prohibit the City from contracting with a third party to perform City maintenance responsibilities covered under this Agreement.

- 5.2. Amendments.** Any amendment to this Agreement must be in writing and will not be effective until it has been executed and approved by the same parties who executed and approved the original Agreement, or their successors in office.
- 5.3. Waiver.** If a party fails to enforce any provision of this Agreement, that failure does not waive the provision or the party's right to subsequently enforce it.
- 5.4. Contract Complete.** This Agreement contains all prior negotiations and agreements between the State and the City. No other understanding regarding this Agreement, whether written or oral, may be used to bind either party.

6. Liability; Worker Compensation Claims; Insurance

Each party is responsible for its own acts, omissions, and the results thereof to the extent authorized by law and will not be responsible for the acts, omissions of others, and the results thereof. Minnesota Statutes § 3.736 and other applicable law govern liability of the State. Minnesota Statutes Chapter 466 and other applicable law govern liability of the City. Each party is responsible for its own employees for any claims arising under the Workers Compensation Act.

7. Nondiscrimination

Provisions of Minnesota Statutes § 181.59 and of any applicable law relating to civil rights and discrimination are considered part of this Agreement.

8. State Audits

Under Minnesota Statutes § 16C.05, subdivision 5, the City's books, records, documents, accounting procedures, and practices relevant to this Agreement are subject to examination by the State and the State Auditor or Legislative Auditor, as appropriate, for a minimum of six years from the end of this Agreement.

9. Government Data Practices

The City and State must comply with the Minnesota Government Data Practices Act, Minnesota Statutes Chapter 13, as it applies to all data provided under this Agreement, and as it applies to all data created, collected, received, stored, used, maintained, or disseminated by the City under this Agreement. The civil remedies of Minnesota Statutes §13.08 apply to the release of the data referred to in this clause by either the City or the State.

10. Governing Law; Jurisdiction; Venue

Minnesota law governs the validity, interpretation, and enforcement of this Agreement. Venue for all legal proceedings arising out of this Agreement, or its breach, must be in the appropriate state or federal court with competent jurisdiction in Ramsey County, Minnesota.

11. Termination; Suspension

- 11.1. By Mutual Agreement.** This Agreement may be terminated by mutual agreement of the parties or by the State for insufficient funding as described below.
- 11.2. Termination for Insufficient Funding.** The State may immediately terminate this Agreement if it does not obtain funding from the Minnesota Legislature, or other funding source; or if funding cannot be continued at a level sufficient to allow for the performance of contract construction under the Project. Termination must be by written or fax notice to the City.

11.3. Suspension. In the event of a total or partial government shutdown, the State may suspend this Agreement and all work, activities and performance of work authorized through this Agreement.

12. Force Majeure

No party will be responsible to the other for a failure to perform under this Agreement (or a delay in performance), if such failure or delay is due to a force majeure event. A force majeure event is an event beyond a party's reasonable control, including but not limited to, unusually severe weather, fire, floods, other acts of God, labor disputes, acts of war or terrorism, or public health emergencies.

[The remainder of this page has been intentionally left blank]

CITY OF MONTICELLO

The undersigned certify that they have lawfully executed this contract on behalf of the Governmental Unit as required by applicable charter provisions, resolutions, or ordinances.

By: _____

Title: _____

Date: _____

By: _____

Title: _____

Date: _____

DEPARTMENT OF TRANSPORTATION

Approved:

By: _____
(District Engineer)

Date: _____

COMMISSIONER OF ADMINISTRATION

By: _____
(With Delegated Authority)

Date: _____

INCLUDE COPY OF RESOLUTION APPROVING THE AGREEMENT AND AUTHORIZING ITS EXECUTION.

CITY OF MONTICELLO

RESOLUTION 2026-07

IT IS RESOLVED that the City of Monticello enter into MnDOT Agreement No. 1061836 with the State of Minnesota, Department of Transportation for the following purposes:

To provide for routine maintenance by the City upon, along, and adjacent to Trunk Highway No. 25, the limits of which are defined in said Agreement.

IT IS FURTHER RESOLVED that the Mayor and the _____
(Title)
are authorized to execute the Agreement and any amendments to the Agreement.

CERTIFICATION

I certify that the above Resolution is an accurate copy of the Resolution adopted by the Council of the City of Monticello at an authorized meeting held on the _____ day of _____, 20__, as shown by the minutes of the meeting in my possession.

Subscribed and sworn to me this _____ day of _____, 20__
Notary Public _____
My Commission Expires _____

_____ (Signature)
_____ (Type or Print Name)
_____ (Title)

- NOTE:
1. CONNECTIONS TO NEW BRIDGE LIGHTING TO BE IN HANDHOLES 1 & 2
 2. INPLACE LIGHT UNITS C1 1 AND C1 8 TO HAVE LED LUMINAIRE INSTALLED
 3. PVC COATED RIGID METAL CONDUIT TO BE USED IN BRIDGE
 4. RED 3M LOCATOR BALLS TO BE PLACED IN HANDHOLES (MNDOT PROVIDED)

FOUNDATION AND LIGHTING UNITS					
NO.	STATION	LT.	RT.	LOCATION	LIGHT UNIT TYPE
1	561+35.022		RT.	NB TH 25	9-40
2	565+14.436		RT.	NB TH 25	SPECIAL
3	566+02.016		RT.	NB TH 25	SPECIAL
4	566+89.596		RT.	NB TH 25	SPECIAL
5	566+71.163	LT.		SB TH 25	SPECIAL
6	565+83.584	LT.		SB TH 25	SPECIAL
7	564+96.00	LT.		SB TH 25	SPECIAL
8	561+59.415	LT.		SB TH 25	9-40

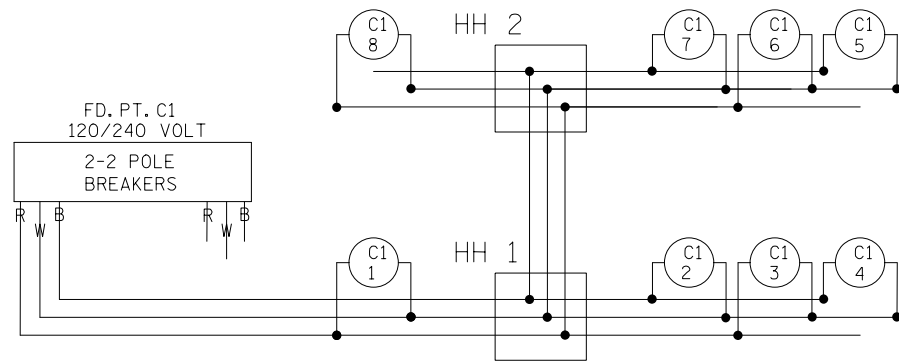

B AND R DENOTE CURRENT CARRYING CONDUCTORS
W DENOTES NEUTRAL CONDUCTOR

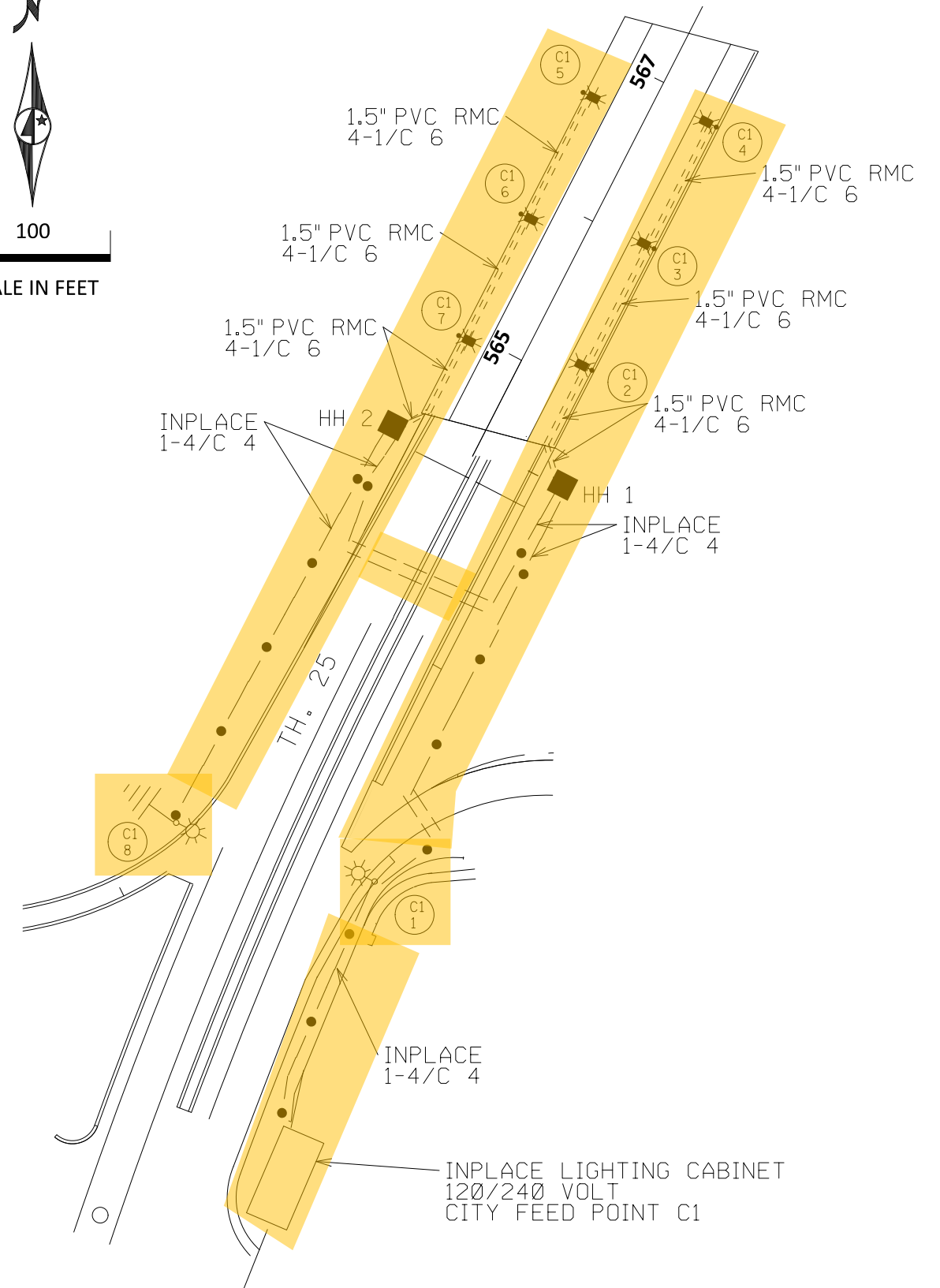
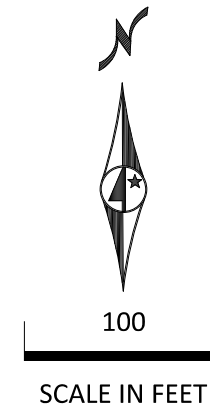
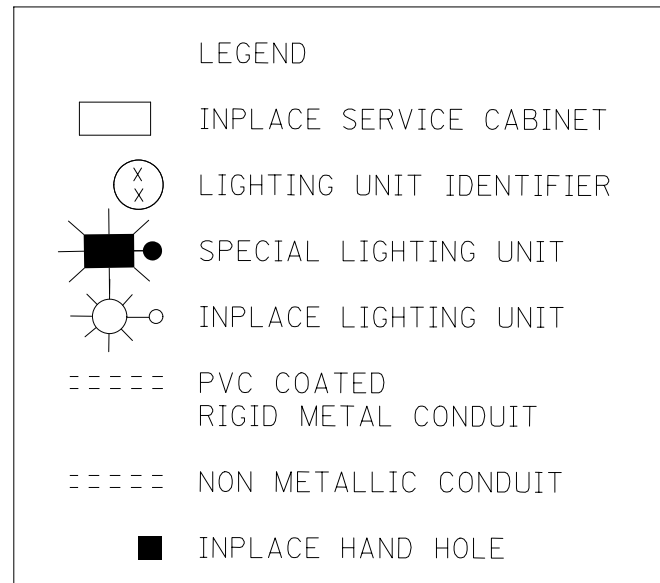

Exhibit A - Lighting

Maintenance and Ownership by the City of Monticello

METER ADDRESS
990 HWY 25 S
MONTICELLO, MN 55362

SYS ID: 24132789

DISTRICT #: \$@DISTRICT@\$
 PLOT NAME: \$\$@PLOTSNAME@\$
 PATH & FILENAME: \$\$\$@PATHFILENAME\$\$\$
 PLOTTED/REVISED: \$\$\$@DATE@\$\$\$

Exhibit B - Concrete Emblem

Maintenance by the City of Monticello

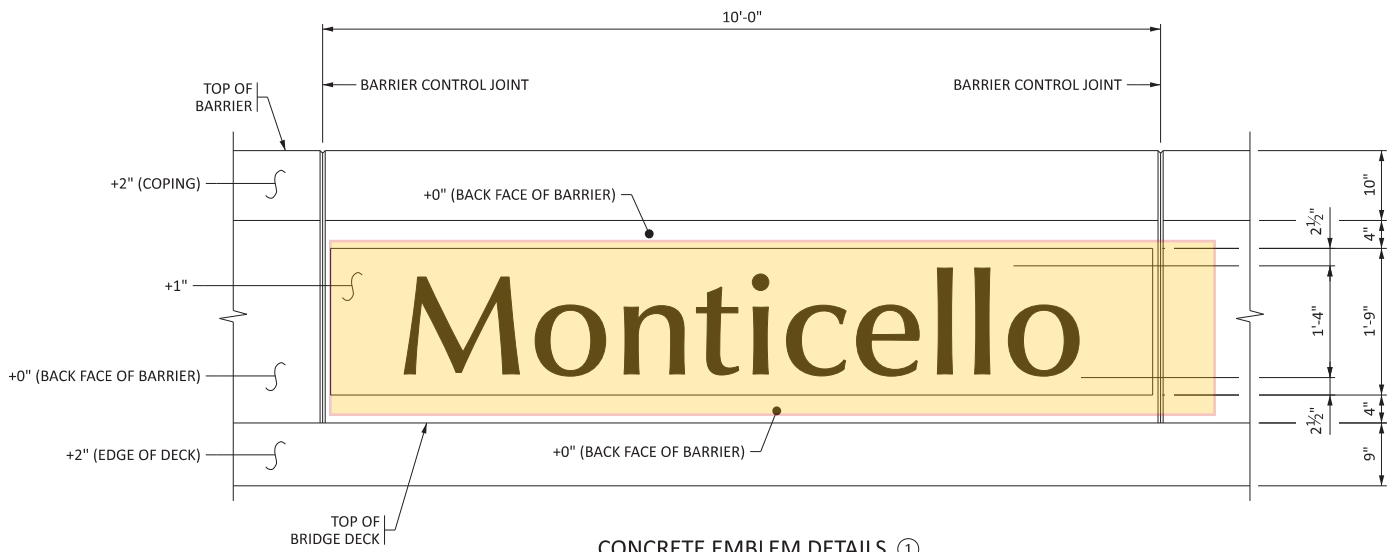

TIME : 9:26:41 PM

PLOTTED : 11/24/2025

PATH & FILENAME : c:\proj\tech\ise\pw_working\pove2\h\1538256\br86803_BEP.dgn

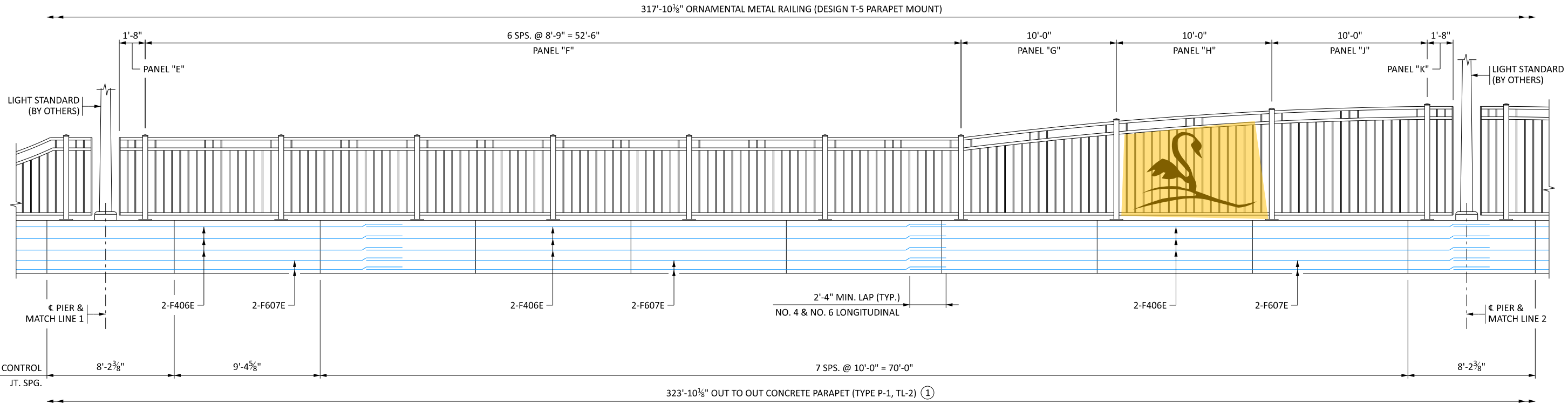
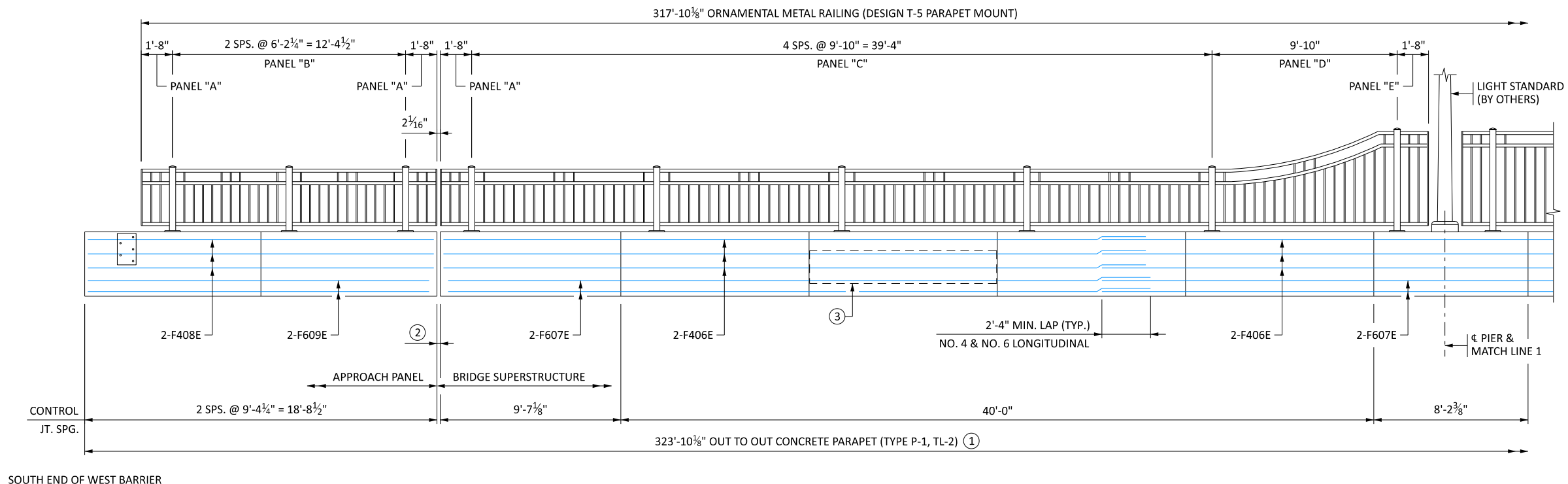

INSIDE ELEVATION CONCRETE PARAPET & ORNAMENTAL RAILING
WEST BARRIER SHOWN (EAST BARRIER SIMILAR)

Exhibit C - Metal Railing Swan Emblem

MAINTENANCE BY CITY OF MONTICELLO

- NOTES:**
- SEE SHEET NO. XX FOR CONCRETE BARRIER AND REINFORCEMENT DETAILS.
 - SEE SHEET NO. XX FOR ORNAMENTAL METAL RAILING DETAILS.
 - SEE SHEET NO. XX FOR RAIL PANEL DETAILS.
 - ① MEASURED ALONG INSIDE FACE OF PARAPET.
 - ② 2" AT ALL TEMPS.
 - ③ SEE SHEET NO. XX FOR DETAILS OF IMPRINTED CONCRETE SIGN. INCLUDED IN ITEM "CONCRETE EMBLEM (SIGNAGE)". LOCATED ON THE WEST BARRIER.

REV. NO.	DATE	REVISION DESCRIPTION	BY	I HEREBY CERTIFY THAT THIS PLAN WAS PREPARED BY ME OR UNDER MY DIRECT SUPERVISION AND THAT I AM A DULY LICENSED PROFESSIONAL ENGINEER UNDER THE LAWS OF THE STATE OF MINNESOTA	CERTIFIED BY: NAME: BRANDON L. DAY LICENSED PROFESSIONAL ENGINEER LIC. NO.: 56027	TITLE: CONCRETE PARAPET & METAL RAILING ELEV. (1 OF 2)	DES: _____ CHK: _____	DR: BEP CHK: _____	APPROVED: _____	BRIDGE NO. 86803
SHEET NO. 14 OF __ SHEETS										

TIME : 9:26:42 PM
 PLOTTED : 11/24/2025
 PATH & FILENAME : c:\proj\tech\ise\pw_working\pove2\bl\1538256\br86803_BEP.dgn

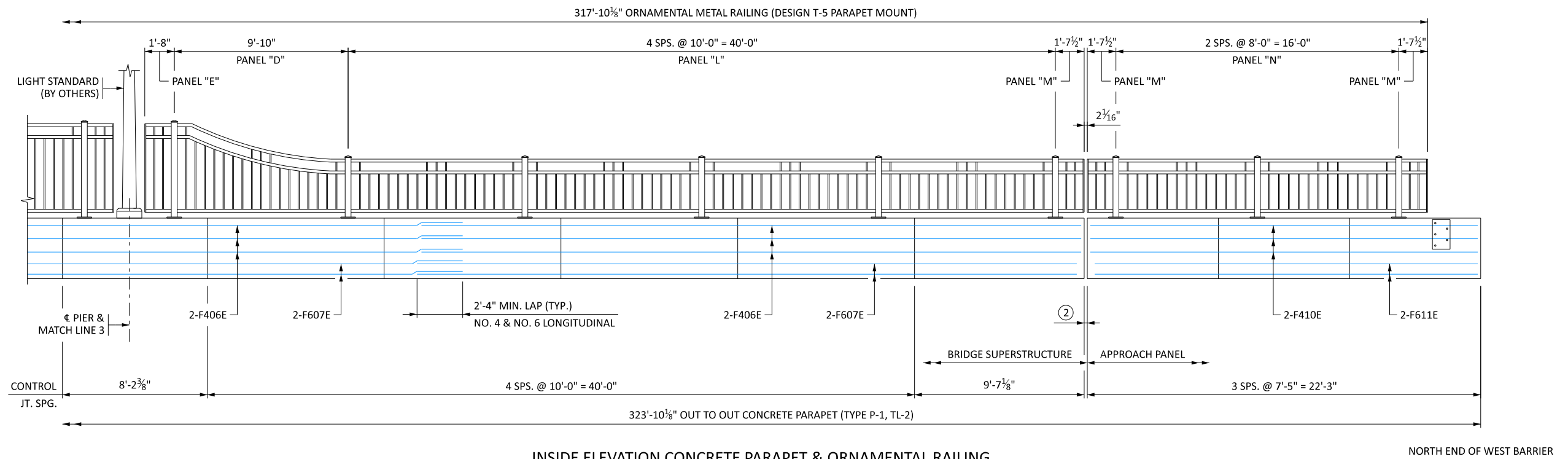
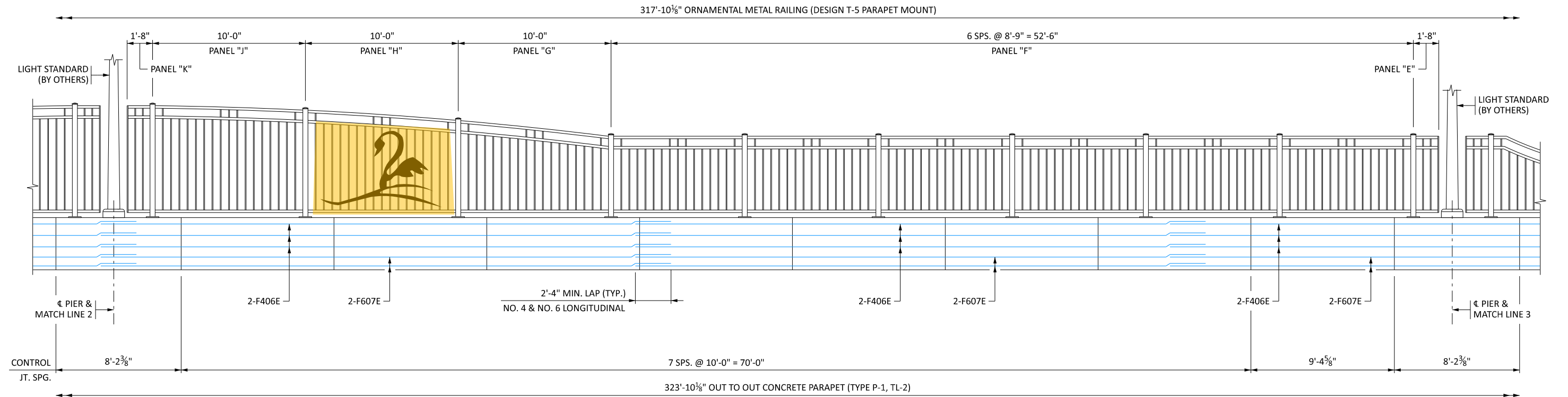

INSIDE ELEVATION CONCRETE PARAPET & ORNAMENTAL RAILING
 WEST BARRIER SHOWN (EAST BARRIER SIMILAR)

Exhibit C - Metal Railing Swan Emblem

MAINTENANCE BY CITY OF MONTICELLO

- NOTES:**
- SEE SHEET NO. XX FOR CONCRETE BARRIER AND REINFORCEMENT DETAILS.
 - SEE SHEET NO. XX FOR ORNAMENTAL METAL RAILING DETAILS.
 - SEE SHEET NO. XX FOR RAIL PANEL DETAILS.
 - ① MEASURED ALONG INSIDE FACE OF PARAPET.
 - ② 2" AT ALL TEMPS.

REV. NO.	DATE	REVISION DESCRIPTION	BY	I HEREBY CERTIFY THAT THIS PLAN WAS PREPARED BY ME OR UNDER MY DIRECT SUPERVISION AND THAT I AM A DULY LICENSED PROFESSIONAL ENGINEER UNDER THE LAWS OF THE STATE OF MINNESOTA	CERTIFIED BY: NAME: BRANDON L. DAY LICENSED PROFESSIONAL ENGINEER DATE LIC. NO.: 56027	TITLE: CONCRETE PARAPET & METAL RAILING ELEV. (2 OF 2)	DES: _____ CHK: _____	DR: BEP CHK: _____	APPROVED:	BRIDGE NO. 86803
								SHEET NO. 15 OF __ SHEETS		

TIME : 9:26:43 PM
 PLOTTED : 11/24/2025
 PATH & FILENAME: c:\project\se\pw_working\pove2\1538256.br86803_BEP.dgn

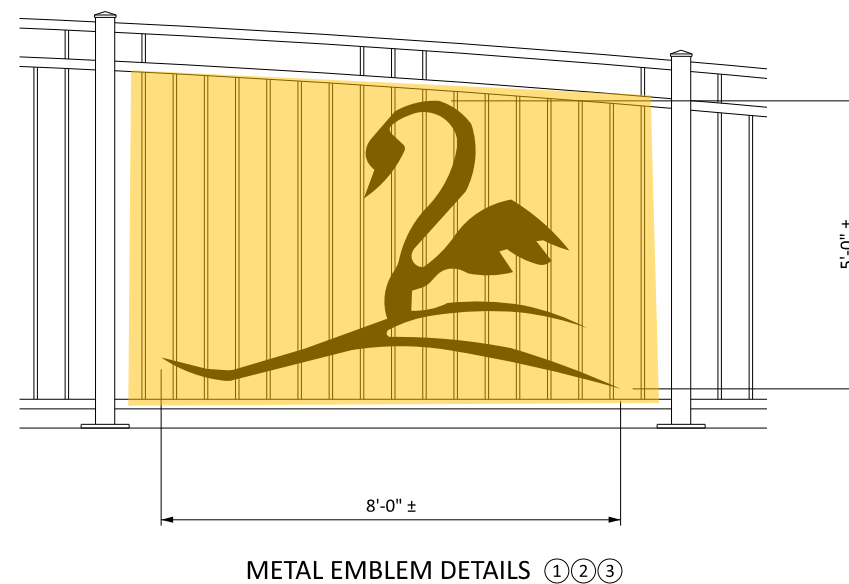
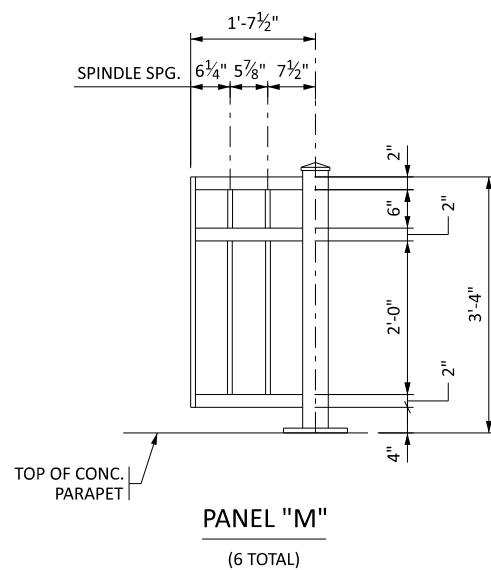
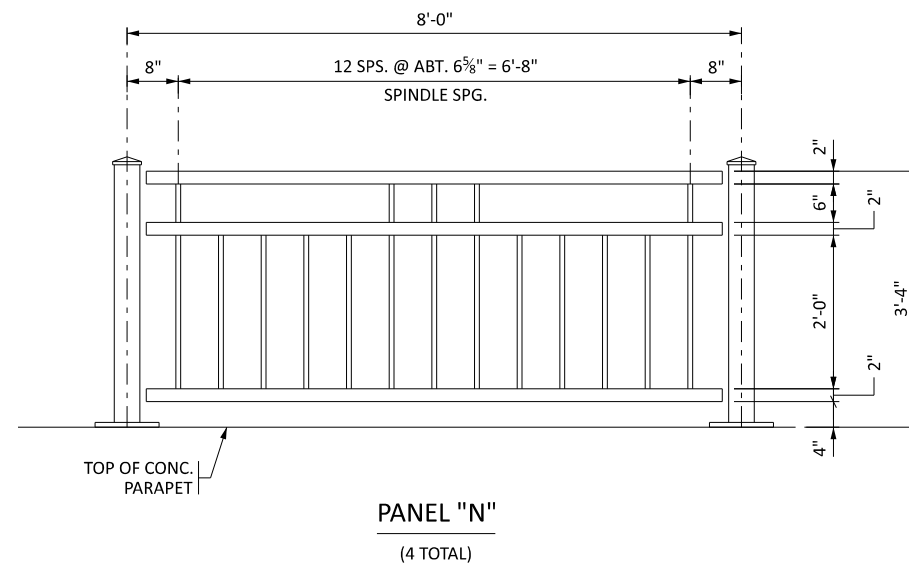
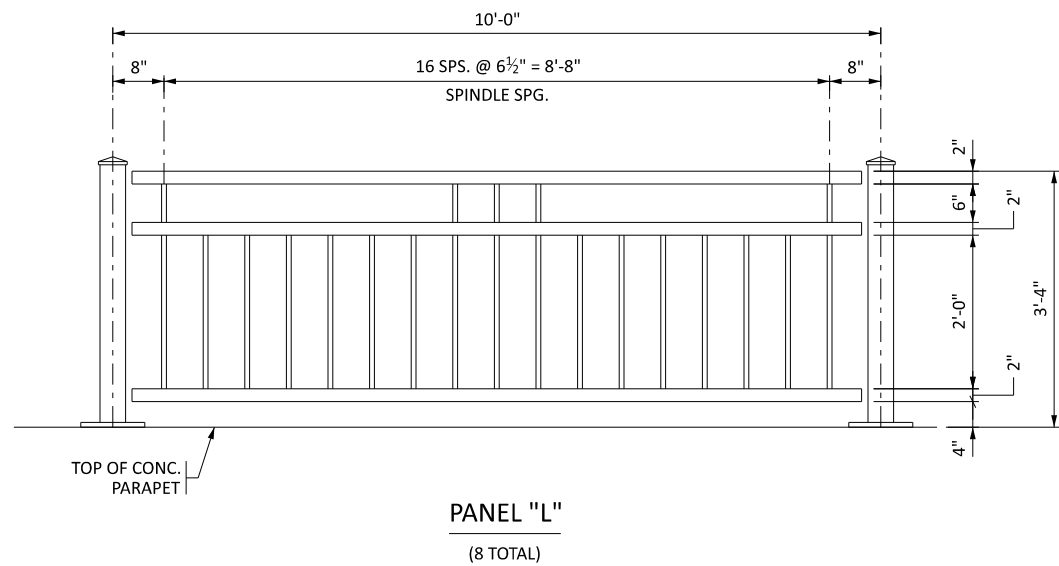

- NOTES:**
- SEE SHEET NO.S XX-XX FOR PANEL LOCATIONS.
 - SEE SHEET NO. XX FOR PANEL DETAILS.
 - ① METAL RAILING EMBLEM INCLUDED IN ITEM "METAL EMBLEM". SEE SPECIAL PROVISIONS. EMBLEM CADD FILE AVAILABLE FOR FABRICATION PURPOSES.
 - ② ALL POINTS TO BE ROUNDED TO MIN. 3/4" RADIUS.
 - ③ WELD METAL EMBLEM TO OUTSIDE (HIGHWAY SIDE) FACE OF RAILING.

Exhibit C - Metal Railing Swan Emblem

MAINTENANCE BY CITY OF MONTICELLO

REV. NO.	DATE	REVISION DESCRIPTION	BY	I HEREBY CERTIFY THAT THIS PLAN WAS PREPARED BY ME OR UNDER MY DIRECT SUPERVISION AND THAT I AM A DULY LICENSED PROFESSIONAL ENGINEER UNDER THE LAWS OF THE STATE OF MINNESOTA	CERTIFIED BY: NAME: BRANDON L. DAY	DATE LIC. NO.: 56027	TITLE: ORNAMENTAL METAL RAILING DETAILS (3 OF 3)	DES: _____	DR: BEP	APPROVED: _____	BRIDGE NO. 86803
								CHK: _____	CHK: _____	SHEET NO. 21 OF __ SHEETS	



Wright County Sheriff's Office

Sheriff Sean Deringer

3800 Braddock Ave. NE, Buffalo, MN 55313
1-800-362-3667 Fax: 763-682-7610



Monticello Monthly Report 2026

Printed on February 2, 2026

Incident Start Date/Time	Initial Call	CFS #	Final Incident	Case Number	How Reported
--------------------------	--------------	-------	----------------	-------------	--------------

911 Abandoned Total: 5

01/09/26 20:40	911 Abandoned	2026002688			911
01/15/26 08:55	911 Abandoned	2026004408			911
01/24/26 11:38	911 Abandoned	2026006762			911
01/24/26 16:11	911 Abandoned	2026006823			911
01/30/26 11:49	911 Abandoned	2026008481			911

911 Abandoned; Medical - Abdominal Pain Total: 1

01/20/26 23:24	911 Abandoned;	2026005861			911
----------------	----------------	------------	--	--	-----

911 Abandoned; Medical - Stroke Total: 1

01/09/26 08:52	911 Abandoned;	2026002443			911
----------------	----------------	------------	--	--	-----

911 Hang-up Total: 19

01/01/26 20:51	911 Hang-up	2026000202			911
01/03/26 20:57	911 Hang-up	2026000811			911
01/04/26 00:12	911 Hang-up	2026000859			911
01/05/26 00:46	911 Hang-up	2026001102			911
01/06/26 15:05	911 Hang-up	2026001590			911
01/14/26 15:00	911 Hang-up	2026004205			911
01/15/26 21:31	911 Hang-up	2026004604			911
01/18/26 18:14	911 Hang-up	2026005265			911
01/19/26 11:16	911 Hang-up	2026005389			911
01/19/26 11:37	911 Hang-up	2026005394			911
01/19/26 20:34	911 Hang-up	2026005537			911
01/20/26 21:48	911 Hang-up	2026005845			911
01/24/26 17:09	911 Hang-up	2026006839			911
01/26/26 15:56	911 Hang-up	2026007433			911
01/27/26 07:05	911 Hang-up	2026007606			911
01/28/26 17:31	911 Hang-up	2026008050			911
01/28/26 20:39	911 Hang-up	2026008089			911
01/29/26 20:42	911 Hang-up	2026008356			911
01/31/26 12:22	911 Hang-up	2026008772			911

911 Open Line Total: 47

01/01/26 12:58	911 Open Line	2026000119			911
01/01/26 19:02	911 Open Line	2026000186			911
01/02/26 11:11	911 Open Line	2026000319			911
01/02/26 14:12	911 Open Line	2026000372			911
01/02/26 14:55	911 Open Line	2026000393			911
01/02/26 14:57	911 Open Line	2026000394			911

Incident Start Date/Time	Initial Call	CFS #	Final Incident	Case Number	How Reported
01/03/26 15:12	911 Open Line	2026000721			911
01/04/26 12:02	911 Open Line	2026000931			911
01/04/26 14:09	911 Open Line	2026000955			911
01/04/26 17:45	911 Open Line	2026001003			911
01/06/26 15:42	911 Open Line	2026001607			911
01/08/26 09:45	911 Open Line	2026002161			911
01/10/26 06:19	911 Open Line	2026002818			911
01/10/26 13:22	911 Open Line	2026002919			911
01/10/26 17:38	911 Open Line	2026003006			911
01/10/26 22:41	911 Open Line	2026003118			911
01/11/26 14:16	911 Open Line	2026003256			911
01/11/26 14:49	911 Open Line	2026003265			911
01/11/26 16:22	911 Open Line	2026003289			911
01/12/26 08:15	911 Open Line	2026003484			911
01/13/26 17:32	911 Open Line	2026003954			911
01/14/26 13:20	911 Open Line	2026004174			911
01/14/26 14:33	911 Open Line	2026004196			911
01/15/26 15:39	911 Open Line	2026004516			911
01/19/26 10:43	911 Open Line	2026005382			911
01/19/26 10:58	911 Open Line	2026005385			911
01/19/26 14:30	911 Open Line	2026005435			911
01/19/26 16:27	911 Open Line	2026005469			911
01/21/26 23:46	911 Open Line	2026006139			911
01/22/26 20:57	911 Open Line	2026006369			911
01/22/26 21:45	911 Open Line	2026006378			911
01/23/26 09:54	911 Open Line	2026006455			911
01/23/26 16:31	911 Open Line	2026006571			911
01/25/26 07:58	911 Open Line	2026007040			911
01/25/26 13:40	911 Open Line	2026007099			911
01/26/26 11:23	911 Open Line	2026007350			911
01/26/26 13:54	911 Open Line	2026007385			911
01/26/26 19:25	911 Open Line	2026007508			911
01/26/26 19:34	911 Open Line	2026007510			911
01/27/26 11:31	911 Open Line	2026007665			911
01/27/26 15:46	911 Open Line	2026007723			911
01/28/26 09:03	911 Open Line	2026007927			911
01/28/26 14:42	911 Open Line	2026008004			911
01/28/26 18:51	911 Open Line	2026008067			911
01/29/26 09:05	911 Open Line	2026008190			911
01/29/26 13:50	911 Open Line	2026008250			911
01/31/26 05:34	911 Open Line	2026008711			911

Abuse Total: 2

01/12/26 16:29	Abuse	2026003624	Abuse	WP26001124	Phone
01/21/26 15:38	Abuse	2026006016	Abuse	WP26001916	Phone

Agency Assist Total: 6

Incident Start Date/Time	Initial Call	CFS #	Final Incident	Case Number	How Reported
01/12/26 15:56	Agency Assist	2026003616	Agency Assist	WP26001127	911
01/15/26 06:24	Agency Assist	2026004383			Phone
01/25/26 23:07	Agency Assist	2026007260			Phone
01/28/26 15:43	Agency Assist	2026008021	Agency Assist	WP26002515	Phone
01/29/26 14:10	Agency Assist	2026008255			Phone
01/29/26 21:53	Agency Assist	2026008367			Phone

Agency Assist; Walk Away Total: 1

01/09/26 11:25	Agency Assist; Walk	2026002484			Phone
----------------	---------------------	------------	--	--	-------

Alarm Total: 2

01/19/26 07:20	Alarm	2026005348			911
01/31/26 21:12	Alarm	2026008912			Phone

Alarm; Dispatch - CAD - Addressing Problems Total: 1

01/22/26 20:01	Alarm; Dispatch - CAD -	2026006356			911
----------------	-------------------------	------------	--	--	-----

Alarm; Fire - Elevator Rescue Total: 1

01/09/26 19:01	Alarm; Fire - Elevator	2026002655			Phone
----------------	------------------------	------------	--	--	-------

Animal Total: 6

01/01/26 04:50	Animal	2026000057	Animal	WP26000020	911
01/07/26 16:30	Animal	2026001945	Animal	WP26000580	Phone
01/07/26 18:28	Animal	2026001988	Animal	WP26000594	Phone
01/08/26 20:38	Animal	2026002346	Animal	WP26000713	Phone
01/28/26 00:19	Animal	2026007864	Animal	WP26002451	Phone
01/29/26 09:59	Animal	2026008201	Animal	WP26002565	Phone

Animal - Barking Dog Total: 2

01/02/26 18:31	Animal - Barking Dog	2026000476	Animal - Barking Dog	WP26000149	Phone
01/20/26 20:37	Animal - Barking Dog	2026005830	Animal - Barking Dog	WP26001854	Phone

Animal; Citizen Aid Total: 1

01/21/26 12:21	Animal; Citizen Aid	2026005968	Animal	WP26001896	Phone
----------------	---------------------	------------	--------	------------	-------

Assault Total: 3

01/02/26 10:59	Assault	2026000316	Assault	WP26000099	Phone
01/04/26 19:08	Assault	2026001021	Disorderly	WP26000304	911
01/13/26 13:10	Assault	2026003863	Assault	WP26001200	Phone

Assault; Domestic Disturbance Total: 1

01/21/26 19:29	Assault; Domestic	2026006077	Domestic Disturbance	WP26001934	Phone
----------------	-------------------	------------	----------------------	------------	-------

Burglary Total: 2

01/15/26 23:22	Burglary	2026004628	Suspicious - Person - Vehicle	WP26001429	911
01/25/26 05:44	Burglary	2026007030	Suspicious - Person - Vehicle	WP26002211	Phone

Check Welfare Total: 28

01/01/26 14:56	Check Welfare	2026000141	Check Welfare	WP26000042	Phone
01/02/26 00:38	Check Welfare	2026000236	Check Welfare	WP26000070	Phone
01/02/26 12:32	Check Welfare	2026000343	Check Welfare	WP26000109	

Incident Start Date/Time	Initial Call	CFS #	Final Incident	Case Number	How Reported
01/04/26 10:06	Check Welfare	2026000908	Check Welfare	WP26000272	Phone
01/06/26 23:20	Check Welfare	2026001746	Check Welfare	WP26000513	Phone
01/09/26 11:03	Check Welfare	2026002475	Check Welfare	WP26000749	Phone
01/09/26 12:56	Check Welfare	2026002512	Check Welfare	WP26000763	Phone
01/11/26 05:01	Check Welfare	2026003177	Check Welfare	WP26000992	911
01/12/26 00:07	Check Welfare	2026003423	Intoxicated Person	WP26001055	911
01/12/26 01:50	Check Welfare	2026003442	Check Welfare	WP26001063	911
01/13/26 12:19	Check Welfare	2026003847	Check Welfare	WP26001191	Phone
01/13/26 20:06	Check Welfare	2026003994	Check Welfare	WP26001242	Phone
01/14/26 04:36	Check Welfare	2026004080	Check Welfare	WP26001265	Phone
01/15/26 09:20	Check Welfare	2026004413	Check Welfare	WP26001371	Phone
01/15/26 13:00	Check Welfare	2026004476	Check Welfare	WP26001393	Phone
01/15/26 23:36	Check Welfare	2026004632	Check Welfare	WP26001430	Phone
01/18/26 13:46	Check Welfare	2026005211	Check Welfare	WP26001636	911
01/18/26 17:51	Check Welfare	2026005256	Check Welfare	WP26001651	911
01/20/26 14:30	Check Welfare	2026005719	Check Welfare	WP26001816	Phone
01/21/26 01:23	Check Welfare	2026005874	Check Welfare	WP26001863	Phone
01/23/26 07:26	Check Welfare	2026006429	Citizen Aid	WP26002024	
01/23/26 23:59	Check Welfare	2026006683	Check Welfare	WP26002102	911
01/25/26 11:34	Check Welfare	2026007071	Check Welfare	WP26002223	Phone
01/28/26 11:36	Check Welfare	2026007966	Check Welfare	WP26002486	
01/28/26 13:03	Check Welfare	2026007989	Check Welfare	WP26002503	Phone
01/28/26 15:01	Check Welfare	2026008008	Check Welfare	WP26002506	Phone
01/28/26 17:25	Check Welfare	2026008048	Check Welfare	WP26002522	911
01/31/26 12:54	Check Welfare	2026008783	Check Welfare	WP26002713	Phone

Check Welfare; Intoxicated Person Total: 1

01/01/26 16:17	Check Welfare;	2026000159	Intoxicated Person	WP26000048	Phone
----------------	----------------	------------	--------------------	------------	-------

Citizen Aid Total: 33

01/01/26 19:47	Citizen Aid	2026000192	Citizen Aid	WP26000058	Phone
01/02/26 12:10	Citizen Aid	2026000336	Citizen Aid	WP26000105	Phone
01/06/26 10:44	Citizen Aid	2026001504	Citizen Aid	WP26000452	911
01/06/26 17:50	Citizen Aid	2026001644			911
01/06/26 18:51	Citizen Aid	2026001667	Citizen Aid	WP26000492	Phone
01/07/26 09:06	Citizen Aid	2026001831	Citizen Aid	WP26000541	911
01/08/26 20:37	Citizen Aid	2026002344	Citizen Aid	WP26000711	Phone
01/09/26 09:53	Citizen Aid	2026002461	Citizen Aid	WP26000741	Phone
01/09/26 22:17	Citizen Aid	2026002720	Vehicle Off Road	WP26000833	Phone
01/10/26 07:36	Citizen Aid	2026002831	Citizen Aid	WP26000889	Phone
01/10/26 22:23	Citizen Aid	2026003109	Citizen Aid	WP26000973	911
01/11/26 03:25	Citizen Aid	2026003174	Citizen Aid	WP26000989	Phone
01/13/26 08:57	Citizen Aid	2026003793	Citizen Aid	WP26001178	911
01/13/26 12:55	Citizen Aid	2026003858	Citizen Aid	WP26001197	Phone
01/13/26 16:14	Citizen Aid	2026003933	Citizen Aid	WP26001223	911
01/14/26 06:22	Citizen Aid	2026004090	Citizen Aid	WP26001269	Phone
01/14/26 16:55	Citizen Aid	2026004245	MVA - No Injuries	WP26001324	Phone

Incident Start Date/Time	Initial Call	CFS #	Final Incident	Case Number	How Reported
01/15/26 10:02	Citizen Aid	2026004430	Citizen Aid	WP26001374	Phone
01/16/26 10:35	Citizen Aid	2026004706	Citizen Aid	WP26001450	Phone
01/17/26 10:45	Citizen Aid	2026004975	Citizen Aid	WP26001567	Phone
01/17/26 10:46	Citizen Aid	2026004976	Citizen Aid	WP26001568	Phone
01/21/26 13:54	Citizen Aid	2026005986	Citizen Aid	WP26001901	Phone
01/21/26 14:52	Citizen Aid	2026006005	Citizen Aid	WP26001912	Phone
01/22/26 13:44	Citizen Aid	2026006257	Citizen Aid	WP26001983	
01/22/26 14:20	Citizen Aid	2026006270	Citizen Aid	WP26001989	Phone
01/23/26 02:25	Citizen Aid	2026006416	Citizen Aid	WP26002021	Phone
01/24/26 22:01	Citizen Aid	2026006953	Citizen Aid	WP26002182	Phone
01/24/26 22:43	Citizen Aid	2026006967	Citizen Aid	WP26002186	Phone
01/25/26 12:59	Citizen Aid	2026007089	Citizen Aid	WP26002227	Phone
01/28/26 18:23	Citizen Aid	2026008059	Citizen Aid	WP26002526	Phone
01/29/26 11:18	Citizen Aid	2026008220	Citizen Aid	WP26002571	Phone
01/30/26 17:25	Citizen Aid	2026008569	Citizen Aid	WP26002650	Phone
01/31/26 16:15	Citizen Aid	2026008834	Citizen Aid	WP26002731	Phone

Civil Complaint Total: 29

01/02/26 10:07	Civil Complaint	2026000305	Civil Complaint	WP26000090	911
01/02/26 17:18	Civil Complaint	2026000444	Civil Complaint	WP26000138	Phone
01/02/26 17:41	Civil Complaint	2026000456	Civil Complaint	WP26000141	Phone
01/02/26 17:54	Civil Complaint	2026000458	Civil Complaint	WP26000144	Phone
01/02/26 18:29	Civil Complaint	2026000474	Civil Complaint	WP26000148	Phone
01/04/26 12:31	Civil Complaint	2026000937	Civil Complaint	WP26000281	911
01/05/26 17:32	Civil Complaint	2026001296	Civil Complaint	WP26000401	Phone
01/07/26 15:16	Civil Complaint	2026001924	Civil Complaint	WP26000571	Phone
01/08/26 16:21	Civil Complaint	2026002265	Civil Complaint	WP26000689	Phone
01/12/26 16:26	Civil Complaint	2026003623	Civil Complaint	WP26001122	Phone
01/13/26 07:32	Civil Complaint	2026003768	Civil Complaint	WP26001169	Phone
01/15/26 09:01	Civil Complaint	2026004409	Civil Complaint	WP26001370	Phone
01/15/26 16:16	Civil Complaint	2026004525	Civil Complaint	WP26001403	911
01/16/26 10:27	Civil Complaint	2026004703	Civil Complaint	WP26001451	Phone
01/16/26 11:28	Civil Complaint	2026004720	Citizen Aid	WP26001461	Phone
01/16/26 11:56	Civil Complaint	2026004725	Civil Complaint	WP26001465	911
01/16/26 22:58	Civil Complaint	2026004875	Civil Complaint	WP26001519	Phone
01/17/26 09:49	Civil Complaint	2026004961	Civil Complaint	WP26001561	Phone
01/17/26 21:20	Civil Complaint	2026005076	Civil Complaint	WP26001596	911
01/19/26 05:46	Civil Complaint	2026005343	Fraud - Internet	WP26001679	Phone
01/19/26 11:32	Civil Complaint	2026005392	Civil Complaint	WP26001720	Phone
01/21/26 17:17	Civil Complaint	2026006035	Parking	WP26001923	911
01/21/26 18:33	Civil Complaint	2026006066	Civil Complaint	WP26001930	Phone
01/23/26 20:54	Civil Complaint	2026006644	Civil Complaint	WP26002086	Phone
01/24/26 13:56	Civil Complaint	2026006789	Civil Complaint	WP26002134	Phone
01/24/26 17:53	Civil Complaint	2026006846	Civil Complaint	WP26002156	911
01/26/26 14:42	Civil Complaint	2026007404	Civil Complaint	WP26002319	911
01/27/26 11:28	Civil Complaint	2026007663	Civil Complaint	WP26002389	911
01/30/26 14:53	Civil Complaint	2026008533	Civil Complaint	WCSU26002639	Phone

Incident Start Date/Time	Initial Call	CFS #	Final Incident	Case Number	How Reported
--------------------------	--------------	-------	----------------	-------------	--------------

Civil Lockout Total: 1

01/30/26 13:00	Civil Lockout	2026008503			
----------------	---------------	------------	--	--	--

Civil Process Total: 40

01/02/26 18:15	Civil Process	2026000471			Officer
01/05/26 15:37	Civil Process	2026001262			Officer
01/06/26 10:47	Civil Process	2026001506			Officer
01/07/26 08:56	Civil Process	2026001827			Officer
01/07/26 17:22	Civil Process	2026001966			Officer
01/08/26 10:53	Civil Process	2026002182			Officer
01/08/26 11:06	Civil Process	2026002184			Officer
01/09/26 16:06	Civil Process	2026002576			Officer
01/09/26 16:29	Civil Process	2026002596			Officer
01/14/26 14:19	Civil Process	2026004187			Officer
01/14/26 14:21	Civil Process	2026004188			Officer
01/14/26 14:33	Civil Process	2026004195			Officer
01/14/26 14:39	Civil Process	2026004198			Officer
01/14/26 14:48	Civil Process	2026004201			Officer
01/14/26 14:58	Civil Process	2026004204			Officer
01/15/26 09:31	Civil Process	2026004419			Officer
01/15/26 09:41	Civil Process	2026004423			Officer
01/15/26 09:51	Civil Process	2026004426			Officer
01/15/26 10:01	Civil Process	2026004429			Officer
01/20/26 13:46	Civil Process	2026005705			Officer
01/20/26 13:53	Civil Process	2026005706			Officer
01/20/26 14:32	Civil Process	2026005722			Officer
01/20/26 15:13	Civil Process	2026005738			Officer
01/20/26 17:24	Civil Process	2026005779			Officer
01/20/26 17:31	Civil Process	2026005782			Officer
01/20/26 17:38	Civil Process	2026005785			Officer
01/20/26 18:01	Civil Process	2026005794			Officer
01/21/26 10:10	Civil Process	2026005938			Officer
01/21/26 10:37	Civil Process	2026005943			Officer
01/21/26 18:24	Civil Process	2026006061			Officer
01/23/26 10:41	Civil Process	2026006464			Officer
01/23/26 10:49	Civil Process	2026006469			Officer
01/23/26 10:59	Civil Process	2026006471			Officer
01/26/26 09:26	Civil Process	2026007321			Officer
01/26/26 19:53	Civil Process	2026007515			Officer
01/27/26 12:18	Civil Process	2026007676			Officer
01/27/26 15:12	Civil Process	2026007712			Officer
01/27/26 16:59	Civil Process	2026007751			Officer
01/28/26 13:51	Civil Process	2026007998			Officer
01/30/26 10:42	Civil Process	2026008471			Officer

Commercial Fire Alarm Total: 4

01/11/26 16:43	Commercial Fire Alarm	2026003293			Phone
----------------	-----------------------	------------	--	--	-------

Incident Start Date/Time	Initial Call	CFS #	Final Incident	Case Number	How Reported
01/13/26 08:44	Commercial Fire Alarm	2026003790			Phone
01/15/26 14:26	Commercial Fire Alarm	2026004492			Phone
01/25/26 19:05	Commercial Fire Alarm	2026007194			911

Commercial General Alarm Total: 24

01/02/26 05:50	Commercial General	2026000257			Phone
01/03/26 20:00	Commercial General	2026000791			Phone
01/04/26 00:18	Commercial General	2026000861			Phone
01/04/26 18:17	Commercial General	2026001012			Phone
01/06/26 04:35	Commercial General	2026001432			Phone
01/09/26 06:24	Commercial General	2026002419			Phone
01/09/26 12:32	Commercial General	2026002502			Phone
01/11/26 14:18	Commercial General	2026003258			Phone
01/15/26 16:25	Commercial General	2026004527			Phone
01/15/26 20:08	Commercial General	2026004581			Phone
01/16/26 17:37	Commercial General	2026004812			Phone
01/16/26 18:31	Commercial General	2026004826			Phone
01/16/26 19:57	Commercial General	2026004846			Phone
01/17/26 06:19	Commercial General	2026004943			Phone
01/17/26 15:35	Commercial General	2026005022			Phone
01/18/26 11:28	Commercial General	2026005188			Phone
01/19/26 03:28	Commercial General	2026005333			Phone
01/22/26 21:20	Commercial General	2026006375			Phone
01/24/26 06:22	Commercial General	2026006724			Text
01/25/26 20:26	Commercial General	2026007220			Phone
01/26/26 05:06	Commercial General	2026007286			Phone
01/28/26 02:14	Commercial General	2026007881			Phone
01/28/26 03:06	Commercial General	2026007888			Phone
01/30/26 20:34	Commercial General	2026008617			Phone

Commercial General Alarm; 911 Text Total: 5

01/07/26 21:12	Commercial General	2026002048			Phone
01/10/26 13:44	Commercial General	2026002924			Text
01/15/26 19:10	Commercial General	2026004573			Phone
01/18/26 23:13	Commercial General	2026005311			Text
01/28/26 21:15	Commercial General	2026008097			Phone

Commercial General Alarm; Commercial Fire Alarm Total: 1

01/23/26 04:57	Commercial General	2026006422			Phone
----------------	--------------------	------------	--	--	-------

Court Order Violation Total: 6

01/02/26 19:33	Court Order Violation	2026000495	Court Order Violation	WP26000155	Phone
01/03/26 22:25	Court Order Violation	2026000831	Court Order Violation	WP26000252	Phone
01/04/26 18:07	Court Order Violation	2026001008	Court Order Violation	WP26000297	Phone
01/10/26 13:40	Court Order Violation	2026002921	Court Order Violation	WP26000915	Phone
01/11/26 13:01	Court Order Violation	2026003242	Court Order Violation	WP26001010	911
01/22/26 13:17	Court Order Violation	2026006252	Court Order Violation	WP26001980	Phone

Incident Start Date/Time	Initial Call	CFS #	Final Incident	Case Number	How Reported
--------------------------	--------------	-------	----------------	-------------	--------------

Court Order Violation; Dispatch - CAD - Addressing Problems Total: 1

01/17/26 01:24	Court Order Violation;	2026004899	Court Order Violation	WP26001528	Phone
----------------	------------------------	------------	-----------------------	------------	-------

Criminal Damage to Property Total: 4

01/02/26 04:59	Criminal Damage to	2026000256	Criminal Damage to Property	WP26000074	911
01/04/26 14:47	Criminal Damage to	2026000961	Criminal Damage to Property	WP26000286	Phone
01/16/26 17:13	Criminal Damage to	2026004806	Criminal Damage to Property	WP26001493	Phone
01/20/26 16:23	Criminal Damage to	2026005759	Criminal Damage to Property	WP26001828	

CSC Sex Offense Total: 2

01/09/26 17:40	CSC Sex Offense	2026002619	CSC Sex Offense	WP26000808	Phone
01/26/26 09:49	CSC Sex Offense	2026007328	CSC Sex Offense	WP26002292	Phone

Disabled Vehicle Total: 7

01/04/26 16:22	Disabled Vehicle	2026000979			Phone
01/21/26 12:28	Disabled Vehicle	2026005970			911
01/26/26 10:59	Disabled Vehicle	2026007345			Officer
01/27/26 14:49	Disabled Vehicle	2026007707			Phone
01/28/26 15:19	Disabled Vehicle	2026008012			Phone
01/30/26 12:42	Disabled Vehicle	2026008497			Officer
01/31/26 23:22	Disabled Vehicle	2026008945			911

Disorderly Total: 3

01/12/26 17:41	Disorderly	2026003650	Disorderly	WP26001134	911
01/29/26 17:27	Disorderly	2026008305	Disorderly	WP26002596	911
01/29/26 17:59	Disorderly	2026008315	Disorderly	WP26002600	Phone

Disorderly; Civil Complaint Total: 1

01/14/26 20:04	Disorderly; Civil	2026004288	Civil Complaint	WP26001337	911
----------------	-------------------	------------	-----------------	------------	-----

Dispatch - CAD - Addressing Problems Total: 1

01/01/26 14:07	Dispatch - CAD -	2026000133			Other
----------------	------------------	------------	--	--	-------

Domestic Disturbance Total: 15

01/02/26 10:55	Domestic Disturbance	2026000314	Domestic Disturbance	WP26000096	911
01/06/26 18:55	Domestic Disturbance	2026001668	Domestic Disturbance	WP26000494	911
01/09/26 23:36	Domestic Disturbance	2026002746	Domestic Disturbance	WP26000841	911
01/10/26 00:09	Domestic Disturbance	2026002752	Domestic Disturbance	WP26000844	911
01/16/26 23:15	Domestic Disturbance	2026004878	Domestic Disturbance	WP26001521	911
01/17/26 11:14	Domestic Disturbance	2026004981	Domestic Disturbance	WP26001571	911
01/18/26 14:30	Domestic Disturbance	2026005220	Domestic Disturbance	WP26001639	Phone
01/18/26 23:59	Domestic Disturbance	2026005320	Domestic Disturbance	WP26001669	911
01/20/26 18:03	Domestic Disturbance	2026005796	Domestic Disturbance	WP26001838	911
01/25/26 06:46	Domestic Disturbance	2026007033	Domestic Disturbance	WP26002212	Phone
01/26/26 18:13	Domestic Disturbance	2026007484	Domestic Disturbance	WP26002340	911
01/27/26 22:41	Domestic Disturbance	2026007839	Domestic Disturbance	WP26002446	Phone
01/29/26 20:06	Domestic Disturbance	2026008344	Domestic Disturbance	WP26002607	911
01/31/26 16:02	Domestic Disturbance	2026008831	Domestic Disturbance	WP26002729	911
01/31/26 17:52	Domestic Disturbance	2026008858	Domestic Disturbance	WP26002740	911

Incident Start Date/Time	Initial Call	CFS #	Final Incident	Case Number	How Reported
--------------------------	--------------	-------	----------------	-------------	--------------

Domestic Disturbance; Intoxicated Person Total: 1

01/01/26 14:03	Domestic Disturbance;	2026000132	Domestic Disturbance	WP26000039	911
----------------	-----------------------	------------	----------------------	------------	-----

Extra Patrol Total: 5

01/08/26 21:37	Extra Patrol	2026002360	Extra Patrol	WP26000714	Phone
01/09/26 17:15	Extra Patrol	2026002612	Extra Patrol	WP26000805	Phone
01/10/26 14:27	Extra Patrol	2026002940	Extra Patrol	WP26000919	Phone
01/12/26 21:01	Extra Patrol	2026003700	Extra Patrol	WP26001149	Phone
01/13/26 16:16	Extra Patrol	2026003934	Extra Patrol	WP26001225	911

Fight Total: 5

01/04/26 20:20	Fight	2026001039	Fight	WP26000312	911
01/10/26 00:52	Fight	2026002761	Disorderly	WP26000845	911
01/13/26 12:47	Fight	2026003854	Fight	WP26001193	Phone
01/19/26 23:11	Fight	2026005562	Fight	WP26001767	911
01/22/26 14:16	Fight	2026006268	Fight	WP26001988	Phone

Fire - Burn Permit Total: 2

01/14/26 15:57	Fire - Burn Permit	2026004230			Phone
01/28/26 08:44	Fire - Burn Permit	2026007921			Phone

Fire - CO Alarm Total: 3

01/09/26 07:41	Fire - CO Alarm	2026002427	Fire - CO Alarm	WP26000736	
01/22/26 22:19	Fire - CO Alarm	2026006384	Fire - CO Alarm	WP26002014	911
01/23/26 07:42	Fire - CO Alarm	2026006431	Fire - CO Alarm	WP26002025	Phone

Fire - CO Alarm; Fire - Gas Leak Total: 1

01/06/26 23:08	Fire - CO Alarm; Fire -	2026001740	Fire - CO Alarm	WP26000512	911
----------------	-------------------------	------------	-----------------	------------	-----

Fire - Elevator Rescue Total: 1

01/27/26 17:09	Fire - Elevator Rescue	2026007759	Fire - Elevator Rescue	WP26002418	Phone
----------------	------------------------	------------	------------------------	------------	-------

Fire - Gas Leak Total: 1

01/16/26 19:33	Fire - Gas Leak	2026004837	Fire - Gas Leak	WP26001505	911
----------------	-----------------	------------	-----------------	------------	-----

Fire - Hazardous Materials Total: 1

01/01/26 00:31	Fire - Hazardous	2026000005	Fire - Gas Leak	WP26000002	Phone
----------------	------------------	------------	-----------------	------------	-------

Fire - Other Total: 1

01/17/26 19:39	Fire - Other	2026005056	Fire - Other	WP26001591	Phone
----------------	--------------	------------	--------------	------------	-------

Fire - Other; Citizen Aid Total: 1

01/06/26 13:01	Fire - Other; Citizen Aid	2026001550	Fire - Other	WP26000459	Phone
----------------	---------------------------	------------	--------------	------------	-------

Fire - Structure Total: 2

01/12/26 12:11	Fire - Structure	2026003550	Fire - Structure	WP26001105	911
01/21/26 20:44	Fire - Structure	2026006101	Fire - Structure	WP26001938	911

Fraud - Checks - Cards Total: 2

01/16/26 11:21	Fraud - Checks - Cards	2026004719	Theft - Identity Theft	WP26001459	Phone
----------------	------------------------	------------	------------------------	------------	-------

Incident Start Date/Time	Initial Call	CFS #	Final Incident	Case Number	How Reported
--------------------------	--------------	-------	----------------	-------------	--------------

01/22/26 10:49	Fraud - Checks - Cards	2026006228	Fraud - Checks - Cards	WP26001970	Phone
----------------	------------------------	------------	------------------------	------------	-------

Fraud - Forgery Total: 1

01/09/26 12:44	Fraud - Forgery	2026002505	Fraud - Forgery	WP26000761	Phone
----------------	-----------------	------------	-----------------	------------	-------

Fraud - Internet Total: 4

01/13/26 12:59	Fraud - Internet	2026003859	Fraud - Internet	WP26001198	
01/14/26 13:55	Fraud - Internet	2026004181	Fraud - Internet	WP26001303	Phone
01/23/26 12:33	Fraud - Internet	2026006498	Fraud - Internet	WP26002043	Phone
01/28/26 10:37	Fraud - Internet	2026007948	Fraud - Internet	WP26002478	

Funeral Escort Total: 1

01/06/26 07:57	Funeral Escort	2026001459			Phone
----------------	----------------	------------	--	--	-------

Harassment Total: 6

01/08/26 14:55	Harassment	2026002238	Harassment	WP26000680	Phone
01/18/26 13:28	Harassment	2026005207	Harassment	WP26001635	Phone
01/18/26 18:42	Harassment	2026005270	Suspicious - Person - Vehicle	WP26001657	911
01/23/26 17:30	Harassment	2026006579	Harassment	WP26002067	Phone
01/25/26 17:41	Harassment	2026007167	Harassment	WP26002249	Phone
01/26/26 14:37	Harassment	2026007402			Phone

Indecent Exposure Total: 2

01/10/26 23:29	Indecent Exposure	2026003135	Indecent Exposure	WP26000980	Phone
01/19/26 13:21	Indecent Exposure	2026005414	Indecent Exposure	WP26001727	Phone

Info Total: 3

01/09/26 08:02	Info	2026002433			
01/26/26 23:42	Info	2026007565			Phone
01/27/26 21:38	Info	2026007822			Phone

Intoxicated Person Total: 6

01/01/26 02:21	Intoxicated Person	2026000037	Intoxicated Person	WP26000010	Phone
01/09/26 21:37	Intoxicated Person	2026002710	DUI	WP26000831	Phone
01/13/26 22:42	Intoxicated Person	2026004042	Intoxicated Person	WP26001252	Phone
01/18/26 01:13	Intoxicated Person	2026005130	DUI	WP26001609	911
01/26/26 04:12	Intoxicated Person	2026007285	Intoxicated Person	WP26002283	Phone
01/31/26 20:37	Intoxicated Person	2026008899	Intoxicated Person	WP26002751	911

Juvenile - Complaint Total: 3

01/03/26 22:49	Juvenile - Complaint	2026000837	Juvenile - Complaint	WP26000256	Phone
01/09/26 10:52	Juvenile - Complaint	2026002472	Juvenile - Complaint	WP26000747	Phone
01/19/26 22:17	Juvenile - Complaint	2026005554	Juvenile - Complaint	WP26001765	911

Juvenile - Party Total: 1

01/01/26 01:23	Juvenile - Party	2026000021	Juvenile - Complaint	WP26000004	911
----------------	------------------	------------	----------------------	------------	-----

Juvenile - Runaway Total: 7

01/02/26 04:05	Juvenile - Runaway	2026000255	Juvenile - Runaway	WP26000073	911
01/07/26 19:05	Juvenile - Runaway	2026002005	Juvenile - Complaint	WP26000597	Phone

Incident Start Date/Time	Initial Call	CFS #	Final Incident	Case Number	How Reported
01/12/26 14:39	Juvenile - Runaway	2026003593	Juvenile - Runaway	WP26001116	Phone
01/15/26 04:47	Juvenile - Runaway	2026004371	Juvenile - Runaway	WP26001356	Phone
01/20/26 09:58	Juvenile - Runaway	2026005646	Juvenile - Runaway	WP26001797	Phone
01/20/26 15:48	Juvenile - Runaway	2026005745	Agency Assist	WP26001827	911
01/20/26 20:04	Juvenile - Runaway	2026005822	Juvenile - Runaway	WP26001850	Phone

Lift Assist Total: 2

01/26/26 08:18	Lift Assist	2026007309			
01/28/26 15:30	Lift Assist	2026008016			

Lock Out - Lock In Total: 3

01/05/26 21:45	Lock Out - Lock In	2026001364	Lock Out - Lock In	WP26000417	Phone
01/07/26 13:08	Lock Out - Lock In	2026001884	Lock Out - Lock In	WP26000558	911
01/16/26 08:32	Lock Out - Lock In	2026004686			911

Lost - Found Property Total: 5

01/07/26 06:20	Lost - Found Property	2026001786	Lost - Found Property	WP26000529	
01/13/26 21:20	Lost - Found Property	2026004021	Lost - Found Property	WP26001247	
01/22/26 22:06	Lost - Found Property	2026006380	Lost - Found Property	WP26002012	911
01/24/26 19:50	Lost - Found Property	2026006891	Lost - Found Property	WP26002169	
01/30/26 20:09	Lost - Found Property	2026008613	Lost - Found Property	WP26002660	

Lost - Found Property; Suspicious - Circumstances Total: 1

01/17/26 02:37	Lost - Found Property;	2026004907	Lost - Found Property	WP26001529	
----------------	------------------------	------------	-----------------------	------------	--

Medical - Abdominal Pain Total: 6

01/10/26 09:21	Medical - Abdominal	2026002857			911
01/15/26 12:03	Medical - Abdominal	2026004462			911
01/18/26 12:42	Medical - Abdominal	2026005203			911
01/20/26 12:32	Medical - Abdominal	2026005687			911
01/25/26 05:23	Medical - Abdominal	2026007028			Phone
01/31/26 04:17	Medical - Abdominal	2026008706			911

Medical - Allergies - Stings Total: 2

01/12/26 14:30	Medical - Allergies -	2026003589			911
01/14/26 01:39	Medical - Allergies -	2026004068			911

Medical - Back Pain Total: 5

01/04/26 16:36	Medical - Back Pain	2026000985			911
01/05/26 17:16	Medical - Back Pain	2026001289			911
01/19/26 19:56	Medical - Back Pain	2026005525			911
01/27/26 08:55	Medical - Back Pain	2026007627			911
01/29/26 19:23	Medical - Back Pain	2026008335			911

Medical - Bleeding - Lacerations Total: 2

01/13/26 09:34	Medical - Bleeding -	2026003801			911
01/31/26 10:18	Medical - Bleeding -	2026008743			911

Medical - Breathing Problems Total: 7

01/01/26 07:57	Medical - Breathing	2026000069			911
----------------	---------------------	------------	--	--	-----

Incident Start Date/Time	Initial Call	CFS #	Final Incident	Case Number	How Reported
01/02/26 18:58	Medical - Breathing	2026000483			911
01/06/26 11:24	Medical - Breathing	2026001519			911
01/06/26 11:33	Medical - Breathing	2026001522			911
01/06/26 15:36	Medical - Breathing	2026001603			911
01/07/26 16:38	Medical - Breathing	2026001949			911
01/25/26 11:03	Medical - Breathing	2026007063			911

Medical - Carbon Monoxide Inhalation Total: 1

01/19/26 12:26	Medical - Carbon	2026005403	Medical - Carbon Monoxide	WP26001722	Phone
----------------	------------------	------------	---------------------------	------------	-------

Medical - Chest Pain Total: 6

01/03/26 09:47	Medical - Chest Pain	2026000631			911
01/06/26 12:55	Medical - Chest Pain	2026001549			911
01/13/26 09:45	Medical - Chest Pain	2026003802			911
01/16/26 13:44	Medical - Chest Pain	2026004755			911
01/18/26 16:37	Medical - Chest Pain	2026005242			911
01/22/26 03:29	Medical - Chest Pain	2026006166			911

Medical - Childbirth - Obstetrics; Medical - Breathing Problems Total: 1

01/03/26 08:41	Medical - Childbirth -	2026000622			911
----------------	------------------------	------------	--	--	-----

Medical - Choking Total: 1

01/02/26 17:40	Medical - Choking	2026000455			911
----------------	-------------------	------------	--	--	-----

Medical - Diabetic Total: 4

01/08/26 16:01	Medical - Diabetic	2026002261			911
01/09/26 18:40	Medical - Diabetic	2026002651			911
01/24/26 22:06	Medical - Diabetic	2026006955			911
01/29/26 16:18	Medical - Diabetic	2026008288			911

Medical - Fall Under 6 Feet Total: 30

01/01/26 16:56	Medical - Fall Under 6	2026000165			Phone
01/02/26 21:46	Medical - Fall Under 6	2026000531			911
01/03/26 03:02	Medical - Fall Under 6	2026000588			Phone
01/03/26 22:02	Medical - Fall Under 6	2026000826			911
01/04/26 03:06	Medical - Fall Under 6	2026000884			911
01/05/26 06:09	Medical - Fall Under 6	2026001120			Phone
01/05/26 15:17	Medical - Fall Under 6	2026001254			911
01/06/26 06:20	Medical - Fall Under 6	2026001441			911
01/06/26 10:32	Medical - Fall Under 6	2026001499			Phone
01/06/26 14:04	Medical - Fall Under 6	2026001570			911
01/07/26 08:41	Medical - Fall Under 6	2026001822			911
01/07/26 14:14	Medical - Fall Under 6	2026001910			911
01/09/26 17:18	Medical - Fall Under 6	2026002613			911
01/10/26 07:14	Medical - Fall Under 6	2026002829			911
01/12/26 08:51	Medical - Fall Under 6	2026003493			911
01/13/26 20:11	Medical - Fall Under 6	2026003997			911
01/14/26 15:49	Medical - Fall Under 6	2026004226			911
01/15/26 02:48	Medical - Fall Under 6	2026004365			Phone

Incident Start Date/Time	Initial Call	CFS #	Final Incident	Case Number	How Reported
01/18/26 03:44	Medical - Fall Under 6	2026005148			911
01/19/26 21:03	Medical - Fall Under 6	2026005544			911
01/21/26 20:23	Medical - Fall Under 6	2026006091			Phone
01/22/26 09:34	Medical - Fall Under 6	2026006202			911
01/22/26 16:19	Medical - Fall Under 6	2026006295			911
01/22/26 16:26	Medical - Fall Under 6	2026006297			911
01/23/26 00:49	Medical - Fall Under 6	2026006405			911
01/23/26 12:08	Medical - Fall Under 6	2026006490			911
01/25/26 22:08	Medical - Fall Under 6	2026007249			Phone
01/26/26 10:59	Medical - Fall Under 6	2026007346			911
01/27/26 07:56	Medical - Fall Under 6	2026007614			911
01/28/26 00:12	Medical - Fall Under 6	2026007863			911

Medical - Fall Under 6 Feet; Medical - Bleeding - Lacerations Total: 1

01/29/26 23:58	Medical - Fall Under 6	2026008384			Phone
----------------	------------------------	------------	--	--	-------

Medical - Heart Problems Total: 3

01/02/26 09:09	Medical - Heart	2026000285			911
01/03/26 04:44	Medical - Heart	2026000593			911
01/12/26 11:06	Medical - Heart	2026003522			911

Medical - Overdose - Poisoning Total: 2

01/01/26 21:34	Medical - Overdose -	2026000209	Medical - Overdose - Poisoning	WP26000061	911
01/26/26 01:11	Medical - Overdose -	2026007275	Intoxicated Person	WP26002280	911

Medical - Psychiatric - Behavioral Total: 13

01/06/26 23:50	Medical - Psychiatric -	2026001750	Medical - Psychiatric -	WP26000515	911
01/07/26 19:35	Medical - Psychiatric -	2026002019	Medical - Psychiatric -	WP26000598	Phone
01/09/26 08:52	Medical - Psychiatric -	2026002442	Medical - Psychiatric -	WP26000738	911
01/13/26 23:06	Medical - Psychiatric -	2026004047	Medical - Psychiatric -	WP26001253	911
01/16/26 15:31	Medical - Psychiatric -	2026004781	Medical - Psychiatric -	WP26001487	911
01/16/26 19:35	Medical - Psychiatric -	2026004838	Medical - Psychiatric -	WP26001506	911
01/17/26 16:08	Medical - Psychiatric -	2026005026	Medical - Psychiatric -	WP26001581	911
01/19/26 15:25	Medical - Psychiatric -	2026005452	Medical - Psychiatric -	WP26001741	911
01/22/26 10:03	Medical - Psychiatric -	2026006211	Medical - Psychiatric -	WP26001964	911
01/23/26 16:07	Medical - Psychiatric -	2026006557	Medical - Psychiatric -	WP26002054	Phone
01/25/26 03:15	Medical - Psychiatric -	2026007018	Medical - Psychiatric -	WP26002203	911
01/25/26 17:57	Medical - Psychiatric -	2026007171	Medical - Psychiatric -	WP26002251	911
01/28/26 22:35	Medical - Psychiatric -	2026008114	Medical - Psychiatric -	WP26002546	Phone

Medical - Seizure Total: 8

01/08/26 20:56	Medical - Seizure	2026002353			911
01/12/26 20:03	Medical - Seizure	2026003684			911
01/13/26 15:25	Medical - Seizure	2026003914			911
01/17/26 14:44	Medical - Seizure	2026005012			911
01/19/26 19:32	Medical - Seizure	2026005514			911
01/20/26 09:16	Medical - Seizure	2026005637			911
01/30/26 10:44	Medical - Seizure	2026008473	Medical - Seizure	WP26002632	911
01/31/26 05:02	Medical - Seizure	2026008709			911

Incident Start Date/Time	Initial Call	CFS #	Final Incident	Case Number	How Reported
--------------------------	--------------	-------	----------------	-------------	--------------

Medical - Sick Total: 15

01/04/26 21:21	Medical - Sick	2026001061			911
01/06/26 08:28	Medical - Sick	2026001464			911
01/11/26 15:09	Medical - Sick	2026003269			911
01/12/26 16:39	Medical - Sick	2026003627			911
01/17/26 11:35	Medical - Sick	2026004984			911
01/21/26 05:40	Medical - Sick	2026005890			911
01/21/26 18:48	Medical - Sick	2026006072			911
01/22/26 14:19	Medical - Sick	2026006269			911
01/23/26 22:00	Medical - Sick	2026006660			911
01/25/26 16:35	Medical - Sick	2026007149			911
01/26/26 08:48	Medical - Sick	2026007316			911
01/27/26 16:20	Medical - Sick	2026007741			911
01/28/26 23:36	Medical - Sick	2026008129			911
01/30/26 10:28	Medical - Sick	2026008468			911
01/31/26 14:00	Medical - Sick	2026008799			911

Medical - Sick; 911 Open Line Total: 1

01/14/26 04:24	Medical - Sick; 911	2026004079	Intoxicated Person	WP26001264	911
----------------	---------------------	------------	--------------------	------------	-----

Medical - Stroke Total: 4

01/08/26 20:58	Medical - Stroke	2026002354			911
01/15/26 09:48	Medical - Stroke	2026004425			911
01/27/26 03:08	Medical - Stroke	2026007586			911
01/30/26 11:05	Medical - Stroke	2026008478			911

Medical - Unconscious - Fainting Total: 4

01/15/26 21:14	Medical - Unconscious -	2026004602	Death Investigation - Natural	WP26001423	911
01/17/26 21:19	Medical - Unconscious -	2026005075			911
01/18/26 14:51	Medical - Unconscious -	2026005223			911
01/23/26 12:16	Medical - Unconscious -	2026006492			911

Medical - Unconscious - Fainting; Medical - Chest Pain Total: 1

01/18/26 09:57	Medical - Unconscious -	2026005178			911
----------------	-------------------------	------------	--	--	-----

Medical - Unconscious - Fainting; Medical - Seizure Total: 1

01/27/26 06:37	Medical - Unconscious -	2026007602			911
----------------	-------------------------	------------	--	--	-----

Motorist Aid Total: 8

01/02/26 01:28	Motorist Aid	2026000243			Officer
01/05/26 17:44	Motorist Aid	2026001300			Officer
01/08/26 18:24	Motorist Aid	2026002304			Officer
01/23/26 01:01	Motorist Aid	2026006408			Officer
01/25/26 19:08	Motorist Aid	2026007196			Phone
01/26/26 18:11	Motorist Aid	2026007480			Officer
01/26/26 21:52	Motorist Aid	2026007549			Phone
01/31/26 02:17	Motorist Aid	2026008691			Phone

Incident Start Date/Time	Initial Call	CFS #	Final Incident	Case Number	How Reported
MVA - Car Deer Total: 2					
01/15/26 05:41	MVA - Car Deer	2026004378	Traffic - Hazard	WP26001358	Phone
01/20/26 16:43	MVA - Car Deer	2026005763	MVA - Car Deer	WP26001830	Phone
MVA - Hit & Run Total: 6					
01/03/26 21:09	MVA - Hit & Run	2026000815	MVA - No Injuries	WP26000248	
01/09/26 12:46	MVA - Hit & Run	2026002507	MVA - Hit & Run	WP26000762	
01/12/26 06:22	MVA - Hit & Run	2026003465	MVA - Hit & Run	WP26001079	
01/14/26 19:48	MVA - Hit & Run	2026004287			911
01/18/26 18:10	MVA - Hit & Run	2026005262	MVA - Hit & Run	WP26001655	
01/26/26 14:15	MVA - Hit & Run	2026007393	MVA - No Injuries	WP26002313	911
MVA - Injuries Total: 8					
01/15/26 17:31	MVA - Injuries	2026004556	MVA - Injuries	WP26001410	911
01/15/26 17:37	MVA - Injuries	2026004560	MVA - Injuries	WP26001412	911
01/17/26 07:17	MVA - Injuries	2026004950	MVA - Injuries	WP26001558	911
01/18/26 11:10	MVA - Injuries	2026005185	Agency Assist	WP26001625	911
01/18/26 17:06	MVA - Injuries	2026005248	MVA - Injuries	WP26001647	911
01/18/26 17:54	MVA - Injuries	2026005258	Agency Assist	WP26001652	911
01/20/26 02:01	MVA - Injuries	2026005587	MVA - Injuries	WP26001777	911
01/24/26 11:33	MVA - Injuries	2026006761	Agency Assist	WP26002125	911
MVA - No Injuries Total: 24					
01/01/26 09:23	MVA - No Injuries	2026000078	MVA - No Injuries	WP26000026	
01/02/26 11:12	MVA - No Injuries	2026000320	MVA - No Injuries	WP26000098	
01/03/26 07:22	MVA - No Injuries	2026000616	MVA - No Injuries	WP26000192	911
01/05/26 16:41	MVA - No Injuries	2026001280	MVA - No Injuries	WP26000397	911
01/05/26 17:19	MVA - No Injuries	2026001291	MVA - No Injuries	WP26000399	
01/06/26 07:26	MVA - No Injuries	2026001454	MVA - No Injuries	WP26000438	
01/07/26 16:00	MVA - No Injuries	2026001933	MVA - No Injuries	WP26000574	
01/08/26 20:14	MVA - No Injuries	2026002335	MVA - No Injuries	WP26000708	
01/09/26 06:00	MVA - No Injuries	2026002416	Agency Assist	WP26000731	
01/09/26 10:15	MVA - No Injuries	2026002464			
01/09/26 10:38	MVA - No Injuries	2026002468	MVA - No Injuries	WP26000745	911
01/10/26 07:01	MVA - No Injuries	2026002826	MVA - No Injuries	WP26000886	
01/10/26 20:58	MVA - No Injuries	2026003076	MVA - No Injuries	WP26000961	911
01/13/26 12:49	MVA - No Injuries	2026003855	MVA - No Injuries	WP26001195	911
01/16/26 22:24	MVA - No Injuries	2026004869	MVA - No Injuries	WP26001516	Officer
01/21/26 22:34	MVA - No Injuries	2026006125	Vehicle Off Road	WP26001943	
01/22/26 08:01	MVA - No Injuries	2026006182	MVA - No Injuries	WSRO26001958	911
01/22/26 17:02	MVA - No Injuries	2026006308	Agency Assist	WP26001996	911
01/23/26 16:29	MVA - No Injuries	2026006570	MVA - No Injuries	WP26002060	
01/27/26 07:10	MVA - No Injuries	2026007608	MVA - No Injuries	WP26002374	911
01/27/26 11:05	MVA - No Injuries	2026007655	MVA - No Injuries	WP26002387	
01/29/26 07:57	MVA - No Injuries	2026008175	MVA - No Injuries	WP26002558	
01/31/26 09:58	MVA - No Injuries	2026008735	MVA - No Injuries	WP26002695	911
01/31/26 10:23	MVA - No Injuries	2026008745	DUI	WP26002698	

Incident Start Date/Time	Initial Call	CFS #	Final Incident	Case Number	How Reported
--------------------------	--------------	-------	----------------	-------------	--------------

Noise Total: 6

01/04/26 21:43	Noise	2026001072	Noise	WP26000321	
01/09/26 21:32	Noise	2026002706	Noise	WP26000830	
01/15/26 21:34	Noise	2026004606	Noise	WP26001421	
01/18/26 19:41	Noise	2026005277	Noise	WP26001660	911
01/20/26 22:16	Noise	2026005848	Noise	WP26001859	
01/26/26 13:33	Noise	2026007379	Noise	WP26002309	

Parking Total: 4

01/07/26 16:21	Parking	2026001942	Parking	WP26000581	
01/10/26 12:35	Parking	2026002909	Parking	WP26000910	
01/12/26 17:16	Parking	2026003640	Parking	WP26001131	
01/13/26 13:30	Parking	2026003872	Parking	WP26001203	

Prowler Total: 1

01/07/26 14:06	Prowler	2026001907	Prowler	WP26000564	911
----------------	---------	------------	---------	------------	-----

Prowler; Intoxicated Person Total: 1

01/17/26 01:20	Prowler; Intoxicated	2026004897	Disorderly	WP26001525	911
----------------	----------------------	------------	------------	------------	-----

Public Works - Utilities Total: 3

01/02/26 10:34	Public Works - Utilities	2026000310	Public Works - Utilities	WP26000094	Phone
01/25/26 07:42	Public Works - Utilities	2026007037	Public Works - Utilities	WP26002214	Phone
01/25/26 16:11	Public Works - Utilities	2026007140	Public Works - Utilities	WP26002243	911

Repossession Total: 4

01/13/26 08:13	Repossession	2026003780			
01/14/26 18:06	Repossession	2026004259			
01/24/26 12:48	Repossession	2026006780			
01/30/26 19:29	Repossession	2026008602			

Residential Fire Alarm Total: 1

01/10/26 22:57	Residential Fire Alarm	2026003123			911
----------------	------------------------	------------	--	--	-----

Residential General Alarm Total: 3

01/02/26 22:29	Residential General	2026000540			Phone
01/14/26 20:35	Residential General	2026004300			Phone
01/29/26 13:06	Residential General	2026008237			Phone

Residential Medical Alarm Total: 3

01/20/26 09:15	Residential Medical	2026005636			Phone
01/22/26 11:25	Residential Medical	2026006231			Phone
01/29/26 10:08	Residential Medical	2026008205			Phone

Residential Medical Alarm; Medical - Abdominal Pain Total: 1

01/25/26 22:08	Residential Medical	2026007248			Phone
----------------	---------------------	------------	--	--	-------

Residential Medical Alarm; Medical - Fall Under 6 Feet Total: 1

01/01/26 03:47	Residential Medical	2026000050			Phone
----------------	---------------------	------------	--	--	-------

Incident Start Date/Time	Initial Call	CFS #	Final Incident	Case Number	How Reported
--------------------------	--------------	-------	----------------	-------------	--------------

Robbery Total: 1

01/05/26 19:26	Robbery	2026001331	Civil Complaint	WP26000410	911
----------------	---------	------------	-----------------	------------	-----

SIA Area Watch Total: 15

01/04/26 13:39	SIA Area Watch	2026000949
01/07/26 06:50	SIA Area Watch	2026001790
01/08/26 20:17	SIA Area Watch	2026002336
01/10/26 17:27	SIA Area Watch	2026003002
01/14/26 19:02	SIA Area Watch	2026004275
01/15/26 14:27	SIA Area Watch	2026004493
01/16/26 10:20	SIA Area Watch	2026004701
01/17/26 00:36	SIA Area Watch	2026004890
01/17/26 21:58	SIA Area Watch	2026005083
01/21/26 06:54	SIA Area Watch	2026005896
01/22/26 06:59	SIA Area Watch	2026006172
01/28/26 06:53	SIA Area Watch	2026007906
01/29/26 06:53	SIA Area Watch	2026008169
01/30/26 07:47	SIA Area Watch	2026008433
01/30/26 22:15	SIA Area Watch	2026008642

SIA Business Walk Through Total: 2

01/22/26 13:31	SIA Business Walk	2026006255
01/31/26 12:33	SIA Business Walk	2026008778

SIA Citizen Aid Total: 1

01/01/26 10:21	SIA Citizen Aid	2026000086	Officer
----------------	-----------------	------------	---------

SIA City Council - City Hall Total: 6

01/06/26 17:56	SIA City Council - City	2026001648	
01/12/26 17:30	SIA City Council - City	2026003644	Officer
01/14/26 15:03	SIA City Council - City	2026004207	
01/15/26 16:28	SIA City Council - City	2026004531	
01/23/26 14:53	SIA City Council - City	2026006531	
01/26/26 17:30	SIA City Council - City	2026007464	Officer

SIA Other Total: 1

01/22/26 23:06	SIA Other	2026006394
----------------	-----------	------------

SIA Parks Total: 7

01/07/26 13:50	SIA Parks	2026001902
01/13/26 09:56	SIA Parks	2026003806
01/13/26 16:10	SIA Parks	2026003932
01/14/26 10:12	SIA Parks	2026004122
01/21/26 13:26	SIA Parks	2026005980
01/29/26 15:48	SIA Parks	2026008281
01/31/26 16:43	SIA Parks	2026008841

Sign - Signal Repair Total: 3

01/03/26 17:59	Sign - Signal Repair	2026000765	Phone
----------------	----------------------	------------	-------

Incident Start Date/Time	Initial Call	CFS #	Final Incident	Case Number	How Reported
01/13/26 11:33	Sign - Signal Repair	2026003837			Phone
01/26/26 13:23	Sign - Signal Repair	2026007377			Phone

Snowbird Total: 16

01/10/26 02:11	Snowbird	2026002780	Snowbird	WP26000855	
01/10/26 02:18	Snowbird	2026002781	Snowbird	WP26000858	
01/10/26 04:08	Snowbird	2026002798	Snowbird	WP26000868	Officer
01/10/26 04:22	Snowbird	2026002800	Snowbird	WP26000870	Officer
01/10/26 04:48	Snowbird	2026002805	Snowbird	WP26000874	Officer
01/10/26 04:50	Snowbird	2026002806	Snowbird	WP26000875	Officer
01/10/26 04:58	Snowbird	2026002808	Snowbird	WP26000877	Officer
01/10/26 05:06	Snowbird	2026002809	Snowbird	WP26000878	Officer
01/10/26 05:15	Snowbird	2026002810	Snowbird	WP26000879	Officer
01/10/26 05:20	Snowbird	2026002811	Snowbird	WP26000880	Officer
01/10/26 05:26	Snowbird	2026002813	Snowbird	WP26000882	Officer
01/12/26 02:02	Snowbird	2026003443	Snowbird	WP26001064	
01/12/26 02:08	Snowbird	2026003444	Snowbird	WP26001065	
01/17/26 03:34	Snowbird	2026004915	Snowbird	WP26001536	Officer
01/17/26 03:50	Snowbird	2026004921	Snowbird	WP26001539	Officer
01/17/26 03:56	Snowbird	2026004922	Snowbird	WP26001540	Officer

Stalking Total: 1

01/26/26 15:34	Stalking	2026007422	Stalking	WP26002322	Phone
----------------	----------	------------	----------	------------	-------

Stolen - Vehicle Total: 1

01/31/26 14:59	Stolen - Vehicle	2026008813	Stolen - Vehicle	WP26002724	911
----------------	------------------	------------	------------------	------------	-----

Stoparm Violation Total: 7

01/08/26 09:56	Stoparm Violation	2026002163	Stoparm Violation	WP26000646	Other
01/14/26 11:09	Stoparm Violation	2026004134	Stoparm Violation	WP26001288	Other
01/16/26 09:29	Stoparm Violation	2026004695	Stoparm Violation	WP26001444	Other
01/28/26 12:39	Stoparm Violation	2026007979	Stoparm Violation	WP26002496	Other
01/28/26 12:43	Stoparm Violation	2026007981	Stoparm Violation	WP26002499	Other
01/28/26 12:49	Stoparm Violation	2026007985	Stoparm Violation	WP26002501	Other
01/29/26 09:27	Stoparm Violation	2026008195	Stoparm Violation	WP26002563	Other

Surveillance Total: 1

01/08/26 06:22	Surveillance	2026002123	Search Warrant	WSIU26000640	
----------------	--------------	------------	----------------	--------------	--

Suspicious - Circumstances Total: 24

01/04/26 10:33	Suspicious -	2026000910	Suspicious - Circumstances	WP26000274	911
01/04/26 15:23	Suspicious -	2026000970	Suspicious - Circumstances	WP26000288	911
01/04/26 18:25	Suspicious -	2026001014	Suspicious - Circumstances	WP26000300	911
01/05/26 08:42	Suspicious -	2026001144	Suspicious - Circumstances	WP26000342	Phone
01/05/26 10:53	Suspicious -	2026001181	Suspicious - Circumstances	WP26000355	Phone
01/09/26 16:22	Suspicious -	2026002587	Suspicious - Circumstances	WP26000799	Phone
01/09/26 20:55	Suspicious -	2026002695	Suspicious - Circumstances	WP26000826	911
01/10/26 01:13	Suspicious -	2026002768	Suspicious - Circumstances	WP26000849	911
01/10/26 14:44	Suspicious -	2026002943	Suspicious - Circumstances	WP26000923	911

Incident Start Date/Time	Initial Call	CFS #	Final Incident	Case Number	How Reported
01/10/26 18:24	Suspicious -	2026003021	Suspicious - Circumstances	WP26000945	911
01/11/26 20:15	Suspicious -	2026003371	Suspicious - Circumstances	WP26001042	911
01/12/26 01:03	Suspicious -	2026003429	Suspicious - Circumstances	WP26001057	911
01/14/26 20:39	Suspicious -	2026004304	Medical - Psychiatric -	WP26001343	911
01/15/26 10:52	Suspicious -	2026004442	Suspicious - Circumstances	WP26001378	911
01/16/26 21:23	Suspicious -	2026004858	Suspicious - Circumstances	WP26001513	911
01/17/26 17:11	Suspicious -	2026005035	Suspicious - Circumstances	WP26001585	Phone
01/18/26 00:19	Suspicious -	2026005116	Suspicious - Circumstances	WP26001607	911
01/18/26 14:34	Suspicious -	2026005221	Suspicious - Circumstances	WP26001640	Phone
01/18/26 18:52	Suspicious -	2026005273	Suspicious - Circumstances	WP26001659	Phone
01/20/26 00:58	Suspicious -	2026005577	Suspicious - Circumstances	WP26001770	911
01/26/26 19:09	Suspicious -	2026007505	Suspicious - Circumstances	WP26002347	911
01/27/26 07:56	Suspicious -	2026007613	Suspicious - Circumstances	WP26002376	Phone
01/31/26 12:35	Suspicious -	2026008779	Suspicious - Circumstances	WP26002712	Phone
01/31/26 22:38	Suspicious -	2026008936	Suspicious - Circumstances	WP26002764	Phone

Suspicious - Person - Vehicle Total: 19

01/03/26 18:08	Suspicious - Person -	2026000766	Suspicious - Person - Vehicle	WP26000237	911
01/03/26 19:46	Suspicious - Person -	2026000788	Suspicious - Person - Vehicle	WP26000242	Phone
01/07/26 14:09	Suspicious - Person -	2026001908	Suspicious - Person - Vehicle	WP26000565	Phone
01/08/26 13:13	Suspicious - Person -	2026002207	Suspicious - Person - Vehicle	WP26000665	911
01/08/26 17:17	Suspicious - Person -	2026002283	Suspicious - Person - Vehicle	WP26000696	Phone
01/14/26 10:24	Suspicious - Person -	2026004124	Suspicious - Person - Vehicle	WP26001283	911
01/14/26 14:13	Suspicious - Person -	2026004186	Suspicious - Person - Vehicle	WP26001306	Phone
01/16/26 13:23	Suspicious - Person -	2026004750	Suspicious - Person - Vehicle	WP26001473	911
01/18/26 03:42	Suspicious - Person -	2026005147	Suspicious - Person - Vehicle	WP26001614	Phone
01/21/26 11:22	Suspicious - Person -	2026005949	Suspicious - Person - Vehicle	WP26001889	911
01/21/26 14:24	Suspicious - Person -	2026005996	Suspicious - Person - Vehicle	WP26001906	911
01/21/26 20:32	Suspicious - Person -	2026006096	Suspicious - Person - Vehicle	WP26001937	911
01/24/26 04:22	Suspicious - Person -	2026006713	Suspicious - Person - Vehicle	WP26002112	Phone
01/24/26 07:55	Suspicious - Person -	2026006733	Suspicious - Person - Vehicle	WP26002117	Phone
01/27/26 01:58	Suspicious - Person -	2026007584	Suspicious - Person - Vehicle	WP26002366	Phone
01/27/26 13:16	Suspicious - Person -	2026007685	Suspicious - Person - Vehicle	WP26002395	911
01/28/26 18:37	Suspicious - Person -	2026008062	Suspicious - Person - Vehicle	WP26002527	Phone
01/29/26 15:10	Suspicious - Person -	2026008267	Suspicious - Person - Vehicle	WP26002586	Phone
01/30/26 12:40	Suspicious - Person -	2026008495	Suspicious - Person - Vehicle	WP26002634	Phone

Suspicious - Person - Vehicle; Criminal Damage to Property Total: 1

01/31/26 23:29	Suspicious - Person -	2026008948	Suspicious - Person - Vehicle	WP26002768	911
----------------	-----------------------	------------	-------------------------------	------------	-----

Theft Total: 8

01/04/26 19:56	Theft	2026001036	Theft	WP26000311	Phone
01/06/26 15:24	Theft	2026001596	Theft	WP26000473	
01/11/26 13:59	Theft	2026003253	Civil Complaint	WP26001013	Phone
01/14/26 07:47	Theft	2026004096	Theft	WP26001271	Phone
01/14/26 15:43	Theft	2026004222	Theft	WP26001315	911
01/20/26 10:36	Theft	2026005652	Theft	WP26001799	Phone
01/21/26 08:06	Theft	2026005904	Theft	WP26001871	

Incident Start Date/Time	Initial Call	CFS #	Final Incident	Case Number	How Reported
01/23/26 19:25	Theft	2026006610	Theft	WP26002072	

Theft; Dispatch - CAD - Addressing Problems Total: 1

01/06/26 13:51	Theft; Dispatch - CAD -	2026001565	Theft	WP26000463	Phone
----------------	-------------------------	------------	-------	------------	-------

Theft - From Vehicle Total: 2

01/12/26 10:29	Theft - From Vehicle	2026003514	Lost - Found Property	WP26001092	Phone
01/26/26 10:24	Theft - From Vehicle	2026007335	Theft - From Vehicle	WP26002294	911

Theft - Identity Theft Total: 1

01/27/26 14:39	Theft - Identity Theft	2026007705	Theft - Identity Theft	WP26002402	Phone
----------------	------------------------	------------	------------------------	------------	-------

Theft - Shoplifting Total: 10

01/06/26 09:47	Theft - Shoplifting	2026001482	Theft - Shoplifting	WP26000447	Phone
01/08/26 17:30	Theft - Shoplifting	2026002287	Theft - Shoplifting	WP26000697	Phone
01/09/26 18:23	Theft - Shoplifting	2026002640	Theft - Shoplifting	WP26000813	Phone
01/10/26 13:46	Theft - Shoplifting	2026002925	Theft - Shoplifting	WP26000916	Phone
01/11/26 14:54	Theft - Shoplifting	2026003266	Theft - Shoplifting	WP26001017	Phone
01/17/26 16:15	Theft - Shoplifting	2026005029	Theft - Shoplifting	WP26001582	Phone
01/24/26 16:59	Theft - Shoplifting	2026006835	Theft - Shoplifting	WP26002152	Phone
01/25/26 11:07	Theft - Shoplifting	2026007065	Theft - Shoplifting	WP26002220	Phone
01/25/26 15:42	Theft - Shoplifting	2026007130	Theft - Shoplifting	WP26002241	Phone
01/26/26 10:47	Theft - Shoplifting	2026007340	Theft - Shoplifting	WP26002298	Phone

Threats Total: 6

01/01/26 23:17	Threats	2026000222	Threats	WP26000066	911
01/08/26 15:01	Threats	2026002242	Threats	WP26000681	Phone
01/09/26 14:50	Threats	2026002545	Threats	WP26000781	911
01/11/26 17:42	Threats	2026003315	Citizen Aid	WP26001028	Phone
01/24/26 10:27	Threats	2026006749	Info	WP26002123	911
01/30/26 13:00	Threats	2026008504	Domestic Disturbance	WP26002636	911

Tow Total: 1

01/02/26 11:45	Tow	2026000325			Phone
----------------	-----	------------	--	--	-------

Traffic - Complaint Total: 12

01/01/26 02:15	Traffic - Complaint	2026000035	Traffic - Complaint	WP26000009	Phone
01/04/26 18:46	Traffic - Complaint	2026001018	Traffic - Complaint	WP26000302	911
01/06/26 14:14	Traffic - Complaint	2026001576	Traffic - Complaint	WP26000464	Phone
01/07/26 16:30	Traffic - Complaint	2026001944	Traffic - Complaint	WP26000578	911
01/08/26 07:50	Traffic - Complaint	2026002136	DUI	WP26000634	911
01/08/26 21:51	Traffic - Complaint	2026002364	Traffic - Complaint	WP26000717	911
01/09/26 09:07	Traffic - Complaint	2026002447			Phone
01/10/26 13:40	Traffic - Complaint	2026002922	Traffic - Complaint	WP26000914	Phone
01/10/26 16:51	Traffic - Complaint	2026002993	Traffic - Complaint	WP26000937	911
01/16/26 10:20	Traffic - Complaint	2026004700	Traffic - Complaint	WP26001448	Phone
01/18/26 11:58	Traffic - Complaint	2026005192	Traffic - Complaint	WP26001629	911
01/22/26 14:07	Traffic - Complaint	2026006266	Traffic - Complaint	WP26001987	Phone

Incident Start Date/Time	Initial Call	CFS #	Final Incident	Case Number	How Reported
Traffic - Hazard Total: 2					
01/02/26 10:10	Traffic - Hazard	2026000306	Traffic - Hazard	WP26000089	
01/21/26 18:18	Traffic - Hazard	2026006060	Traffic - Hazard	WP26001929	Phone

Traffic Stop Total: 481

01/01/26 00:52	Traffic Stop	2026000010			Officer
01/01/26 01:59	Traffic Stop	2026000032			Officer
01/01/26 02:09	Traffic Stop	2026000034	DUI	WP26000011	Officer
01/01/26 06:44	Traffic Stop	2026000063			Officer
01/01/26 09:03	Traffic Stop	2026000075			Officer
01/01/26 09:34	Traffic Stop	2026000079			Officer
01/01/26 10:10	Traffic Stop	2026000084			Officer
01/01/26 11:35	Traffic Stop	2026000102			Officer
01/01/26 11:41	Traffic Stop	2026000103			Officer
01/01/26 11:45	Traffic Stop	2026000104			Officer
01/01/26 13:52	Traffic Stop	2026000129	Traffic Stop	WP26000038	Officer
01/01/26 14:18	Traffic Stop	2026000134			Officer
01/01/26 17:46	Traffic Stop	2026000177	Traffic Stop	WP26000052	Officer
01/01/26 19:36	Traffic Stop	2026000190			Officer
01/01/26 20:37	Traffic Stop	2026000200			Officer
01/01/26 21:06	Traffic Stop	2026000205			Officer
01/01/26 21:31	Traffic Stop	2026000208			Officer
01/01/26 22:48	Traffic Stop	2026000217			Officer
01/01/26 23:24	Traffic Stop	2026000223			Officer
01/02/26 01:09	Traffic Stop	2026000239			Officer
01/02/26 01:12	Traffic Stop	2026000240			Officer
01/02/26 14:22	Traffic Stop	2026000378	Traffic Stop	WP26000123	Officer
01/02/26 15:02	Traffic Stop	2026000399	Traffic Stop	WP26000129	Officer
01/02/26 15:21	Traffic Stop	2026000405			Officer
01/02/26 15:24	Traffic Stop	2026000408			Officer
01/02/26 15:29	Traffic Stop	2026000410	Traffic Stop	WP26000130	Officer
01/02/26 15:43	Traffic Stop	2026000415			Officer
01/02/26 15:50	Traffic Stop	2026000416			Officer
01/02/26 16:01	Traffic Stop	2026000420	Traffic Stop	WP26000133	Officer
01/02/26 20:18	Traffic Stop	2026000505			Officer
01/02/26 20:30	Traffic Stop	2026000508	Traffic Stop	WP26000162	Officer
01/02/26 22:03	Traffic Stop	2026000535			Officer
01/02/26 22:16	Traffic Stop	2026000536			Officer
01/02/26 23:24	Traffic Stop	2026000551			Officer
01/02/26 23:43	Traffic Stop	2026000554			Officer
01/02/26 23:58	Traffic Stop	2026000555			Officer
01/03/26 00:22	Traffic Stop	2026000560			Officer
01/03/26 01:51	Traffic Stop	2026000578	Traffic Stop	WP26000179	Officer
01/03/26 02:27	Traffic Stop	2026000584			Officer
01/03/26 07:08	Traffic Stop	2026000615	Traffic Stop	WP26000191	Officer
01/03/26 10:47	Traffic Stop	2026000650			Officer
01/03/26 12:48	Traffic Stop	2026000677	Traffic Stop	WP26000212	Officer

Incident Start Date/Time	Initial Call	CFS #	Final Incident	Case Number	How Reported
01/03/26 13:40	Traffic Stop	2026000693	Traffic Stop	WP26000217	Officer
01/03/26 14:17	Traffic Stop	2026000706	Traffic Stop	WP26000222	Officer
01/03/26 14:40	Traffic Stop	2026000713			Officer
01/03/26 15:05	Traffic Stop	2026000719			Officer
01/03/26 15:14	Traffic Stop	2026000723			Officer
01/03/26 15:22	Traffic Stop	2026000725	Traffic Stop	WP26000228	Officer
01/03/26 15:32	Traffic Stop	2026000727	Traffic Stop	WP26000229	Officer
01/03/26 15:59	Traffic Stop	2026000732			Officer
01/03/26 17:13	Traffic Stop	2026000756			Officer
01/03/26 17:20	Traffic Stop	2026000757			Officer
01/03/26 17:35	Traffic Stop	2026000758			Officer
01/03/26 18:38	Traffic Stop	2026000775			Officer
01/03/26 19:08	Traffic Stop	2026000782			Officer
01/03/26 19:12	Traffic Stop	2026000783	Traffic Stop	WP26000241	Officer
01/03/26 20:25	Traffic Stop	2026000799			Officer
01/03/26 22:13	Traffic Stop	2026000828			Officer
01/03/26 23:12	Traffic Stop	2026000844			Officer
01/04/26 01:40	Traffic Stop	2026000874			Officer
01/04/26 10:56	Traffic Stop	2026000919	Traffic Stop	WP26000276	Officer
01/04/26 11:48	Traffic Stop	2026000927			Officer
01/04/26 12:37	Traffic Stop	2026000938			Officer
01/04/26 13:02	Traffic Stop	2026000940	Traffic Stop	WP26000282	Officer
01/04/26 15:07	Traffic Stop	2026000963			Officer
01/04/26 19:39	Traffic Stop	2026001031			Officer
01/04/26 20:33	Traffic Stop	2026001043			Officer
01/04/26 21:00	Traffic Stop	2026001055			Officer
01/04/26 22:13	Traffic Stop	2026001076			Officer
01/04/26 22:57	Traffic Stop	2026001089			Officer
01/05/26 00:09	Traffic Stop	2026001099	Drugs	WP26000328	Officer
01/05/26 10:48	Traffic Stop	2026001177			Officer
01/05/26 11:24	Traffic Stop	2026001187			Officer
01/05/26 11:31	Traffic Stop	2026001192	Traffic Stop	WP26000359	Officer
01/05/26 12:00	Traffic Stop	2026001203			Officer
01/05/26 12:28	Traffic Stop	2026001207	Traffic Stop	WP26000368	Officer
01/05/26 12:45	Traffic Stop	2026001213			Officer
01/05/26 14:05	Traffic Stop	2026001228			Officer
01/05/26 14:38	Traffic Stop	2026001240			Officer
01/05/26 16:23	Traffic Stop	2026001277			Officer
01/05/26 18:57	Traffic Stop	2026001322			Officer
01/05/26 19:05	Traffic Stop	2026001325			Officer
01/05/26 19:10	Traffic Stop	2026001327	Traffic Stop	WP26000407	Officer
01/05/26 19:27	Traffic Stop	2026001332			Officer
01/05/26 19:50	Traffic Stop	2026001336			Officer
01/05/26 21:34	Traffic Stop	2026001361			Officer
01/05/26 21:50	Traffic Stop	2026001367			Officer
01/06/26 11:16	Traffic Stop	2026001516			Officer
01/06/26 12:20	Traffic Stop	2026001537			Officer

Incident Start Date/Time	Initial Call	CFS #	Final Incident	Case Number	How Reported
01/06/26 12:52	Traffic Stop	2026001546			Officer
01/06/26 14:23	Traffic Stop	2026001579			Officer
01/06/26 14:32	Traffic Stop	2026001583	Traffic Stop	WP26000467	Officer
01/06/26 15:47	Traffic Stop	2026001611			Officer
01/06/26 15:54	Traffic Stop	2026001613			Officer
01/06/26 16:04	Traffic Stop	2026001618			Officer
01/06/26 16:29	Traffic Stop	2026001628	Traffic Stop	WP26000482	Officer
01/06/26 18:01	Traffic Stop	2026001651	Traffic Stop	WP26000487	Officer
01/06/26 18:44	Traffic Stop	2026001663			Officer
01/06/26 19:30	Traffic Stop	2026001679			Officer
01/06/26 20:12	Traffic Stop	2026001686			Officer
01/06/26 20:24	Traffic Stop	2026001695			Officer
01/06/26 20:32	Traffic Stop	2026001701	Traffic Stop	WP26000502	Officer
01/06/26 20:44	Traffic Stop	2026001706	Traffic Stop	WP26000503	Officer
01/06/26 21:14	Traffic Stop	2026001714			Officer
01/06/26 21:31	Traffic Stop	2026001719			Officer
01/06/26 21:41	Traffic Stop	2026001724			Officer
01/06/26 21:42	Traffic Stop	2026001726			Officer
01/06/26 22:08	Traffic Stop	2026001730			Officer
01/06/26 22:49	Traffic Stop	2026001735	Traffic Stop	WP26000510	Officer
01/06/26 23:38	Traffic Stop	2026001748			Officer
01/07/26 09:40	Traffic Stop	2026001840			Officer
01/07/26 13:29	Traffic Stop	2026001894			Officer
01/07/26 17:36	Traffic Stop	2026001970			Officer
01/07/26 18:00	Traffic Stop	2026001974			Officer
01/07/26 18:07	Traffic Stop	2026001979			Officer
01/07/26 19:16	Traffic Stop	2026002010			Officer
01/07/26 21:30	Traffic Stop	2026002054			Officer
01/07/26 21:31	Traffic Stop	2026002057			Officer
01/07/26 21:34	Traffic Stop	2026002058			Officer
01/07/26 21:35	Traffic Stop	2026002059			Officer
01/07/26 21:56	Traffic Stop	2026002066			Officer
01/07/26 22:21	Traffic Stop	2026002071			Officer
01/07/26 22:49	Traffic Stop	2026002081			Officer
01/07/26 23:27	Traffic Stop	2026002088			Officer
01/07/26 23:31	Traffic Stop	2026002091	Traffic Stop	WP26000615	Officer
01/07/26 23:46	Traffic Stop	2026002094	Traffic Stop	WP26000617	Officer
01/07/26 23:46	Traffic Stop	2026002095			Officer
01/08/26 00:07	Traffic Stop	2026002096			Officer
01/08/26 02:19	Traffic Stop	2026002108			Officer
01/08/26 03:17	Traffic Stop	2026002115			Officer
01/08/26 05:49	Traffic Stop	2026002121			Officer
01/08/26 10:59	Traffic Stop	2026002183			Officer
01/08/26 12:19	Traffic Stop	2026002194			Officer
01/08/26 17:08	Traffic Stop	2026002280	Traffic Stop	WP26000693	Officer
01/08/26 18:42	Traffic Stop	2026002310			Officer
01/08/26 18:46	Traffic Stop	2026002313			Officer

Incident Start Date/Time	Initial Call	CFS #	Final Incident	Case Number	How Reported
01/08/26 19:12	Traffic Stop	2026002319			Officer
01/08/26 20:06	Traffic Stop	2026002332			Officer
01/08/26 20:41	Traffic Stop	2026002348			Officer
01/08/26 21:41	Traffic Stop	2026002361	Traffic Stop	WP26000716	Officer
01/08/26 23:41	Traffic Stop	2026002385			Officer
01/09/26 08:00	Traffic Stop	2026002431	Traffic Stop	WP26000737	Officer
01/09/26 09:30	Traffic Stop	2026002452	Traffic Stop	WP26000739	Officer
01/09/26 11:06	Traffic Stop	2026002477	Traffic Stop	WP26000750	Officer
01/09/26 11:18	Traffic Stop	2026002482	Traffic Stop	WP26000752	Officer
01/09/26 12:28	Traffic Stop	2026002500	Traffic Stop	WP26000757	Officer
01/09/26 13:20	Traffic Stop	2026002517			Officer
01/09/26 14:21	Traffic Stop	2026002536			Officer
01/09/26 14:59	Traffic Stop	2026002551			Officer
01/09/26 15:48	Traffic Stop	2026002569			Officer
01/09/26 16:33	Traffic Stop	2026002599			Officer
01/09/26 16:59	Traffic Stop	2026002606	Traffic Stop	WP26000801	Officer
01/09/26 18:57	Traffic Stop	2026002654			Officer
01/09/26 19:17	Traffic Stop	2026002664			Officer
01/09/26 19:34	Traffic Stop	2026002669			Officer
01/09/26 19:43	Traffic Stop	2026002673			Officer
01/09/26 20:15	Traffic Stop	2026002680	Traffic Stop	WP26000823	Officer
01/09/26 23:20	Traffic Stop	2026002735	Traffic Stop	WP26000839	Officer
01/10/26 01:33	Traffic Stop	2026002771			Officer
01/10/26 02:02	Traffic Stop	2026002779			Officer
01/10/26 08:19	Traffic Stop	2026002842			Officer
01/10/26 09:11	Traffic Stop	2026002855			Officer
01/10/26 10:30	Traffic Stop	2026002871			Officer
01/10/26 10:41	Traffic Stop	2026002874			Officer
01/10/26 11:35	Traffic Stop	2026002889			Officer
01/10/26 11:49	Traffic Stop	2026002893			Officer
01/10/26 14:40	Traffic Stop	2026002942	Traffic Stop	WP26000921	Officer
01/10/26 15:22	Traffic Stop	2026002957			Officer
01/10/26 15:39	Traffic Stop	2026002964	Traffic Stop	WP26000930	Officer
01/10/26 16:03	Traffic Stop	2026002974	Traffic Stop	WP26000933	Officer
01/10/26 16:30	Traffic Stop	2026002986			Officer
01/10/26 17:20	Traffic Stop	2026002998			Officer
01/10/26 17:30	Traffic Stop	2026003003			Officer
01/10/26 18:33	Traffic Stop	2026003027	Traffic Stop	WP26000946	Officer
01/10/26 19:38	Traffic Stop	2026003047			Officer
01/10/26 19:53	Traffic Stop	2026003050			Officer
01/10/26 20:03	Traffic Stop	2026003054			Officer
01/10/26 20:12	Traffic Stop	2026003057			Officer
01/10/26 20:48	Traffic Stop	2026003071	Traffic Stop	WP26000960	Officer
01/10/26 20:59	Traffic Stop	2026003077	Traffic Stop	WP26000962	Officer
01/10/26 21:02	Traffic Stop	2026003080	Traffic Stop	WP26000965	Officer
01/10/26 21:19	Traffic Stop	2026003089	Traffic Stop	WP26000966	Officer
01/10/26 21:29	Traffic Stop	2026003093	Traffic Stop	WP26000967	Officer

Incident Start Date/Time	Initial Call	CFS #	Final Incident	Case Number	How Reported
01/10/26 22:09	Traffic Stop	2026003104			Officer
01/10/26 22:21	Traffic Stop	2026003107	Traffic Stop	WP26000972	Officer
01/10/26 22:35	Traffic Stop	2026003113	Traffic Stop	WP26000976	Officer
01/10/26 22:35	Traffic Stop	2026003114	Traffic Stop	WP26000975	Officer
01/10/26 23:59	Traffic Stop	2026003143			Officer
01/11/26 00:20	Traffic Stop	2026003149			Officer
01/11/26 01:05	Traffic Stop	2026003154			Officer
01/11/26 01:50	Traffic Stop	2026003163			Officer
01/11/26 12:41	Traffic Stop	2026003236	Traffic Stop	WP26001006	Officer
01/11/26 13:01	Traffic Stop	2026003243			Officer
01/11/26 18:01	Traffic Stop	2026003324	Traffic Stop	WP26001029	Officer
01/11/26 18:20	Traffic Stop	2026003334			Officer
01/11/26 18:50	Traffic Stop	2026003347	Traffic Stop	WP26001032	Officer
01/11/26 19:13	Traffic Stop	2026003352			Officer
01/11/26 19:16	Traffic Stop	2026003353	Traffic Stop	WP26001035	Officer
01/11/26 19:48	Traffic Stop	2026003362			Officer
01/11/26 19:54	Traffic Stop	2026003365	Traffic Stop	WP26001039	Officer
01/11/26 20:43	Traffic Stop	2026003378			Officer
01/11/26 20:57	Traffic Stop	2026003382			Officer
01/11/26 21:53	Traffic Stop	2026003392			Officer
01/11/26 21:54	Traffic Stop	2026003394			Officer
01/11/26 22:35	Traffic Stop	2026003398			Officer
01/11/26 23:16	Traffic Stop	2026003408			Officer
01/12/26 01:30	Traffic Stop	2026003435			Officer
01/12/26 07:50	Traffic Stop	2026003478			Officer
01/12/26 11:52	Traffic Stop	2026003543	Traffic Stop	WP26001102	Officer
01/12/26 11:54	Traffic Stop	2026003545			Officer
01/12/26 13:00	Traffic Stop	2026003564			Officer
01/12/26 17:54	Traffic Stop	2026003656			Officer
01/12/26 21:01	Traffic Stop	2026003701	Traffic Stop	WP26001148	Officer
01/12/26 21:26	Traffic Stop	2026003708			Officer
01/12/26 22:32	Traffic Stop	2026003721	Drugs	WP26001150	Officer
01/13/26 07:42	Traffic Stop	2026003771			Officer
01/13/26 11:39	Traffic Stop	2026003838			Officer
01/13/26 13:26	Traffic Stop	2026003870			Officer
01/13/26 15:54	Traffic Stop	2026003927			Officer
01/13/26 19:36	Traffic Stop	2026003987			Officer
01/13/26 20:04	Traffic Stop	2026003993			Officer
01/13/26 20:47	Traffic Stop	2026004010			Officer
01/13/26 20:49	Traffic Stop	2026004011			Officer
01/13/26 21:06	Traffic Stop	2026004018			Officer
01/13/26 21:23	Traffic Stop	2026004022	Traffic Stop	WP26001248	Officer
01/13/26 21:54	Traffic Stop	2026004030			Officer
01/13/26 23:09	Traffic Stop	2026004049			Officer
01/13/26 23:28	Traffic Stop	2026004055			Officer
01/13/26 23:34	Traffic Stop	2026004057			Officer
01/14/26 07:28	Traffic Stop	2026004095			Officer

Incident Start Date/Time	Initial Call	CFS #	Final Incident	Case Number	How Reported
01/14/26 12:24	Traffic Stop	2026004154			Officer
01/14/26 13:48	Traffic Stop	2026004180	Traffic Stop	WP26001302	Officer
01/14/26 14:35	Traffic Stop	2026004197	Traffic Stop	WP26001308	Officer
01/14/26 14:56	Traffic Stop	2026004202			Officer
01/14/26 15:09	Traffic Stop	2026004210			Officer
01/14/26 15:18	Traffic Stop	2026004213			Officer
01/14/26 19:29	Traffic Stop	2026004281			Officer
01/14/26 20:25	Traffic Stop	2026004296			Officer
01/14/26 20:34	Traffic Stop	2026004297			Officer
01/14/26 20:34	Traffic Stop	2026004298	Traffic Stop	WP26001340	Officer
01/14/26 21:12	Traffic Stop	2026004312	Drugs	WP26001347	Officer
01/14/26 21:15	Traffic Stop	2026004313			Officer
01/14/26 21:54	Traffic Stop	2026004331			Officer
01/15/26 00:16	Traffic Stop	2026004357			Officer
01/15/26 09:05	Traffic Stop	2026004411			Officer
01/15/26 10:34	Traffic Stop	2026004439	Warrant - Arrest	WSIU26001379	Officer
01/15/26 12:57	Traffic Stop	2026004475	Traffic Stop	WP26001392	Officer
01/15/26 20:22	Traffic Stop	2026004584			Officer
01/15/26 20:34	Traffic Stop	2026004589			Officer
01/15/26 20:38	Traffic Stop	2026004591			Officer
01/15/26 20:46	Traffic Stop	2026004592			Officer
01/15/26 20:53	Traffic Stop	2026004595	DUI	WP26001422	Officer
01/15/26 21:07	Traffic Stop	2026004598			Officer
01/15/26 23:02	Traffic Stop	2026004622			Officer
01/15/26 23:34	Traffic Stop	2026004630	Traffic Stop	WP26001432	Officer
01/16/26 00:00	Traffic Stop	2026004635	Traffic Stop	WP26001433	Officer
01/16/26 01:50	Traffic Stop	2026004648			Officer
01/16/26 02:15	Traffic Stop	2026004654	Drugs	WP26001435	Officer
01/16/26 12:49	Traffic Stop	2026004736	Traffic Stop	WP26001468	Officer
01/16/26 19:12	Traffic Stop	2026004831			Officer
01/17/26 00:21	Traffic Stop	2026004888			Officer
01/17/26 00:43	Traffic Stop	2026004892			Officer
01/17/26 04:52	Traffic Stop	2026004932			Officer
01/17/26 05:14	Traffic Stop	2026004935			Officer
01/17/26 05:31	Traffic Stop	2026004937			Officer
01/17/26 05:45	Traffic Stop	2026004938			Officer
01/17/26 12:18	Traffic Stop	2026004990	Traffic Stop	WP26001573	Officer
01/17/26 14:59	Traffic Stop	2026005016			Officer
01/17/26 15:14	Traffic Stop	2026005018			Officer
01/17/26 15:50	Traffic Stop	2026005024			Officer
01/17/26 18:31	Traffic Stop	2026005048	Traffic Stop	WP26001590	Officer
01/17/26 20:06	Traffic Stop	2026005064			Officer
01/17/26 20:20	Traffic Stop	2026005068			Officer
01/17/26 22:46	Traffic Stop	2026005095			Officer
01/17/26 23:40	Traffic Stop	2026005106			Officer
01/17/26 23:48	Traffic Stop	2026005108			Officer
01/17/26 23:48	Traffic Stop	2026005109	Traffic Stop	WP26001606	Officer

Incident Start Date/Time	Initial Call	CFS #	Final Incident	Case Number	How Reported
01/17/26 23:57	Traffic Stop	2026005111			Officer
01/18/26 01:00	Traffic Stop	2026005126			Officer
01/18/26 01:14	Traffic Stop	2026005131			Officer
01/18/26 01:16	Traffic Stop	2026005132			Officer
01/18/26 02:10	Traffic Stop	2026005142			Officer
01/18/26 14:48	Traffic Stop	2026005222			Officer
01/18/26 20:18	Traffic Stop	2026005287	Traffic Stop	WP26001663	Officer
01/19/26 01:03	Traffic Stop	2026005325	Drugs	WP26001672	Officer
01/19/26 01:10	Traffic Stop	2026005327	Drugs	WP26001671	Officer
01/19/26 13:28	Traffic Stop	2026005415	Traffic Stop	WP26001732	Officer
01/19/26 13:54	Traffic Stop	2026005424			Officer
01/19/26 14:16	Traffic Stop	2026005431	Traffic Stop	WP26001736	Officer
01/19/26 15:18	Traffic Stop	2026005449			Officer
01/19/26 15:52	Traffic Stop	2026005457			Officer
01/19/26 16:09	Traffic Stop	2026005460			Officer
01/19/26 18:41	Traffic Stop	2026005504			Officer
01/19/26 18:59	Traffic Stop	2026005508			Officer
01/19/26 19:52	Traffic Stop	2026005523			Officer
01/19/26 20:07	Traffic Stop	2026005530			Officer
01/19/26 20:18	Traffic Stop	2026005533			Officer
01/19/26 23:16	Traffic Stop	2026005563			Officer
01/20/26 07:45	Traffic Stop	2026005612			Officer
01/20/26 12:20	Traffic Stop	2026005685			Officer
01/20/26 14:28	Traffic Stop	2026005718	Traffic Stop	WP26001814	Officer
01/20/26 15:55	Traffic Stop	2026005747			Officer
01/20/26 19:14	Traffic Stop	2026005809			Officer
01/20/26 19:20	Traffic Stop	2026005812			Officer
01/20/26 19:39	Traffic Stop	2026005816			Officer
01/20/26 19:56	Traffic Stop	2026005819			Officer
01/20/26 20:55	Traffic Stop	2026005834			Officer
01/20/26 23:27	Traffic Stop	2026005862			Officer
01/21/26 00:08	Traffic Stop	2026005867			Officer
01/21/26 10:21	Traffic Stop	2026005941			Officer
01/21/26 13:59	Traffic Stop	2026005988	Traffic Stop	WP26001902	Officer
01/21/26 18:27	Traffic Stop	2026006064			Officer
01/21/26 19:19	Traffic Stop	2026006075			Officer
01/21/26 20:32	Traffic Stop	2026006095			Officer
01/21/26 22:50	Traffic Stop	2026006129			Officer
01/22/26 00:48	Traffic Stop	2026006150			Officer
01/22/26 02:29	Traffic Stop	2026006162			Officer
01/22/26 19:31	Traffic Stop	2026006346			Officer
01/22/26 22:08	Traffic Stop	2026006381	Traffic Stop	WP26002013	Officer
01/22/26 22:58	Traffic Stop	2026006392			Officer
01/22/26 23:31	Traffic Stop	2026006397			Officer
01/23/26 13:01	Traffic Stop	2026006501			Officer
01/23/26 14:16	Traffic Stop	2026006519			Officer
01/23/26 14:37	Traffic Stop	2026006525			Officer

Incident Start Date/Time	Initial Call	CFS #	Final Incident	Case Number	How Reported
01/23/26 14:54	Traffic Stop	2026006532	Traffic Stop	WP26002049	Officer
01/23/26 15:06	Traffic Stop	2026006535			Officer
01/23/26 16:08	Traffic Stop	2026006558			Officer
01/23/26 16:10	Traffic Stop	2026006559	Traffic Stop	WP26002055	Officer
01/23/26 16:10	Traffic Stop	2026006560	Traffic Stop	WP26002056	Officer
01/23/26 17:14	Traffic Stop	2026006578			Officer
01/23/26 18:03	Traffic Stop	2026006584			Officer
01/23/26 18:34	Traffic Stop	2026006590			Officer
01/23/26 19:05	Traffic Stop	2026006599			Officer
01/23/26 19:06	Traffic Stop	2026006600			Officer
01/23/26 19:47	Traffic Stop	2026006615			Officer
01/23/26 20:15	Traffic Stop	2026006626	Traffic Stop	WP26002080	Officer
01/23/26 20:33	Traffic Stop	2026006631			Officer
01/23/26 20:40	Traffic Stop	2026006634	Traffic Stop	WP26002083	Officer
01/23/26 21:14	Traffic Stop	2026006649			Officer
01/23/26 21:15	Traffic Stop	2026006650	Traffic Stop	WP26002092	Officer
01/23/26 22:47	Traffic Stop	2026006672			Officer
01/23/26 22:55	Traffic Stop	2026006674			Officer
01/23/26 23:24	Traffic Stop	2026006679			Officer
01/23/26 23:53	Traffic Stop	2026006682			Officer
01/24/26 00:29	Traffic Stop	2026006686			Officer
01/24/26 00:49	Traffic Stop	2026006687			Officer
01/24/26 01:28	Traffic Stop	2026006695			Officer
01/24/26 01:47	Traffic Stop	2026006699	Traffic Stop	WP26002107	Officer
01/24/26 02:18	Traffic Stop	2026006703			Officer
01/24/26 05:27	Traffic Stop	2026006717	Traffic Stop	WP26002113	Officer
01/24/26 05:50	Traffic Stop	2026006719			Officer
01/24/26 07:41	Traffic Stop	2026006730			Officer
01/24/26 12:38	Traffic Stop	2026006777			Officer
01/24/26 15:12	Traffic Stop	2026006808			Officer
01/24/26 15:19	Traffic Stop	2026006809	Traffic Stop	WP26002144	Officer
01/24/26 15:44	Traffic Stop	2026006814			Officer
01/24/26 18:06	Traffic Stop	2026006850			Officer
01/24/26 18:17	Traffic Stop	2026006855	Traffic Stop	WP26002157	Officer
01/24/26 19:46	Traffic Stop	2026006889	Traffic Stop	WP26002168	Officer
01/24/26 20:00	Traffic Stop	2026006894			Officer
01/24/26 20:56	Traffic Stop	2026006917			Officer
01/24/26 21:04	Traffic Stop	2026006923			Officer
01/24/26 21:13	Traffic Stop	2026006928	Traffic Stop	WP26002178	Officer
01/24/26 21:22	Traffic Stop	2026006934			Officer
01/24/26 21:32	Traffic Stop	2026006938			Officer
01/24/26 21:35	Traffic Stop	2026006939			Officer
01/24/26 21:40	Traffic Stop	2026006942	Traffic Stop	WP26002180	Officer
01/24/26 22:15	Traffic Stop	2026006959			Officer
01/24/26 22:16	Traffic Stop	2026006960			Officer
01/24/26 22:37	Traffic Stop	2026006964			Officer
01/24/26 23:35	Traffic Stop	2026006984			Officer

Incident Start Date/Time	Initial Call	CFS #	Final Incident	Case Number	How Reported
01/25/26 00:35	Traffic Stop	2026006995	Traffic Stop	WP26002193	Officer
01/25/26 02:22	Traffic Stop	2026007011			Officer
01/25/26 05:25	Traffic Stop	2026007029			Officer
01/25/26 09:10	Traffic Stop	2026007051			Officer
01/25/26 10:13	Traffic Stop	2026007058	Traffic Stop	WP26002219	Officer
01/25/26 13:24	Traffic Stop	2026007092			Officer
01/25/26 14:43	Traffic Stop	2026007113			Officer
01/25/26 15:17	Traffic Stop	2026007120	Traffic Stop	WP26002239	Officer
01/25/26 15:47	Traffic Stop	2026007135			Officer
01/25/26 17:18	Traffic Stop	2026007161			Officer
01/25/26 18:37	Traffic Stop	2026007183			Officer
01/25/26 18:44	Traffic Stop	2026007187			Officer
01/25/26 19:02	Traffic Stop	2026007191			Officer
01/25/26 19:03	Traffic Stop	2026007193			Officer
01/25/26 19:35	Traffic Stop	2026007209			Officer
01/25/26 20:29	Traffic Stop	2026007221			Officer
01/25/26 20:31	Traffic Stop	2026007222			Officer
01/25/26 21:12	Traffic Stop	2026007238			Officer
01/25/26 22:40	Traffic Stop	2026007253			Officer
01/26/26 00:32	Traffic Stop	2026007268			Officer
01/26/26 11:28	Traffic Stop	2026007352			Officer
01/26/26 12:26	Traffic Stop	2026007367	Traffic Stop	WP26002307	Officer
01/26/26 12:45	Traffic Stop	2026007369			Officer
01/26/26 14:12	Traffic Stop	2026007390			Officer
01/26/26 16:02	Traffic Stop	2026007438			Officer
01/26/26 17:31	Traffic Stop	2026007465			Officer
01/26/26 17:37	Traffic Stop	2026007466			Officer
01/26/26 17:58	Traffic Stop	2026007476			Officer
01/26/26 17:59	Traffic Stop	2026007478			Officer
01/26/26 18:43	Traffic Stop	2026007493			Officer
01/26/26 18:44	Traffic Stop	2026007494			Officer
01/26/26 20:24	Traffic Stop	2026007522			Officer
01/26/26 21:49	Traffic Stop	2026007547			Officer
01/26/26 21:50	Traffic Stop	2026007548			Officer
01/26/26 22:19	Traffic Stop	2026007555			Officer
01/26/26 22:33	Traffic Stop	2026007557			Officer
01/27/26 01:31	Traffic Stop	2026007579			Officer
01/27/26 01:35	Traffic Stop	2026007581			Officer
01/27/26 01:42	Traffic Stop	2026007583			Officer
01/27/26 05:14	Traffic Stop	2026007595			Officer
01/27/26 14:16	Traffic Stop	2026007702			Officer
01/27/26 16:53	Traffic Stop	2026007750			Officer
01/27/26 19:40	Traffic Stop	2026007790			Officer
01/27/26 20:11	Traffic Stop	2026007796			Officer
01/27/26 20:26	Traffic Stop	2026007799			Officer
01/27/26 21:03	Traffic Stop	2026007809			Officer
01/27/26 21:20	Traffic Stop	2026007816	Traffic Stop	WP26002435	Officer

Incident Start Date/Time	Initial Call	CFS #	Final Incident	Case Number	How Reported
01/27/26 21:39	Traffic Stop	2026007823			Officer
01/27/26 21:57	Traffic Stop	2026007827			Officer
01/27/26 21:57	Traffic Stop	2026007828	Traffic Stop	WP26002439	Officer
01/27/26 21:58	Traffic Stop	2026007829	Traffic Stop	WP26002441	Officer
01/27/26 22:15	Traffic Stop	2026007833			Officer
01/27/26 22:21	Traffic Stop	2026007835	Traffic Stop	WP26002443	Officer
01/27/26 23:13	Traffic Stop	2026007848			Officer
01/27/26 23:30	Traffic Stop	2026007852			Officer
01/28/26 00:06	Traffic Stop	2026007861			Officer
01/28/26 00:46	Traffic Stop	2026007869			Officer
01/28/26 03:01	Traffic Stop	2026007887			Officer
01/28/26 03:26	Traffic Stop	2026007889			Officer
01/28/26 04:39	Traffic Stop	2026007892	Traffic Stop	WP26002457	Officer
01/28/26 04:43	Traffic Stop	2026007893	Traffic Stop	WP26002458	Officer
01/28/26 05:21	Traffic Stop	2026007898	Traffic Stop	WP26002460	Officer
01/28/26 08:40	Traffic Stop	2026007920			Officer
01/28/26 09:42	Traffic Stop	2026007937	Traffic Stop	WP26002471	Officer
01/28/26 17:06	Traffic Stop	2026008047			Officer
01/28/26 20:46	Traffic Stop	2026008091			Officer
01/28/26 23:24	Traffic Stop	2026008127			Officer
01/29/26 00:00	Traffic Stop	2026008131			Officer
01/29/26 01:36	Traffic Stop	2026008147			Officer
01/29/26 01:51	Traffic Stop	2026008152			Officer
01/29/26 02:03	Traffic Stop	2026008154			Officer
01/29/26 02:21	Traffic Stop	2026008155			Officer
01/29/26 13:25	Traffic Stop	2026008242			Officer
01/29/26 14:45	Traffic Stop	2026008263			Officer
01/29/26 15:32	Traffic Stop	2026008272			Officer
01/29/26 17:23	Traffic Stop	2026008304	Traffic Stop	WP26002595	Officer
01/29/26 19:36	Traffic Stop	2026008337			Officer
01/29/26 21:19	Traffic Stop	2026008358			Officer
01/29/26 22:05	Traffic Stop	2026008368			Officer
01/29/26 22:51	Traffic Stop	2026008374			Officer
01/29/26 23:02	Traffic Stop	2026008375			Officer
01/30/26 00:15	Traffic Stop	2026008388			Officer
01/30/26 00:58	Traffic Stop	2026008393			Officer
01/30/26 01:09	Traffic Stop	2026008395			Officer
01/30/26 01:57	Traffic Stop	2026008400			Officer
01/30/26 01:57	Traffic Stop	2026008401	Traffic Stop	WP26002614	Officer
01/30/26 02:27	Traffic Stop	2026008406			Officer
01/30/26 17:38	Traffic Stop	2026008573			Officer
01/30/26 17:45	Traffic Stop	2026008577			Officer
01/30/26 18:31	Traffic Stop	2026008588			Officer
01/30/26 19:16	Traffic Stop	2026008598			Officer
01/30/26 19:52	Traffic Stop	2026008609			Officer
01/30/26 20:08	Traffic Stop	2026008612	Traffic Stop	WP26002659	Officer
01/30/26 20:34	Traffic Stop	2026008618			Officer

Incident Start Date/Time	Initial Call	CFS #	Final Incident	Case Number	How Reported
01/30/26 21:11	Traffic Stop	2026008627			Officer
01/30/26 21:25	Traffic Stop	2026008632	DUI	WP26002667	Officer
01/30/26 22:43	Traffic Stop	2026008650			Officer
01/30/26 22:57	Traffic Stop	2026008658	Traffic Stop	WP26002673	Officer
01/31/26 00:26	Traffic Stop	2026008670			Officer
01/31/26 00:40	Traffic Stop	2026008674			Officer
01/31/26 00:48	Traffic Stop	2026008675	Drugs	WP26002681	Officer
01/31/26 01:46	Traffic Stop	2026008684			Officer
01/31/26 03:08	Traffic Stop	2026008700			Officer
01/31/26 10:19	Traffic Stop	2026008744			Officer
01/31/26 10:26	Traffic Stop	2026008747			Officer
01/31/26 14:01	Traffic Stop	2026008800			Officer
01/31/26 15:20	Traffic Stop	2026008822			Officer
01/31/26 20:34	Traffic Stop	2026008898			Officer
01/31/26 20:49	Traffic Stop	2026008905			Officer
01/31/26 22:42	Traffic Stop	2026008937			Officer

Traffic Stop ; SIA Citizen Aid Total: 1

01/25/26 17:34	Traffic Stop ; SIA	2026007165			Officer
----------------	--------------------	------------	--	--	---------

Training Total: 7

01/06/26 18:19	Training	2026001655			Phone
01/12/26 11:23	Training	2026003528			
01/13/26 07:52	Training	2026003776			
01/14/26 08:04	Training	2026004098			
01/20/26 09:22	Training	2026005639			
01/22/26 13:53	Training	2026006260			Phone
01/26/26 09:52	Training	2026007330			

Unwanted Person Total: 2

01/14/26 06:08	Unwanted Person	2026004089	Unwanted Person	WP26001268	Phone
01/15/26 04:17	Unwanted Person	2026004369	Warrant - Arrest	WP26001355	911

Unwanted Person; Intoxicated Person Total: 1

01/08/26 21:52	Unwanted Person;	2026002365	DUI	WP26000718	911
----------------	------------------	------------	-----	------------	-----

Vehicle Off Road Total: 5

01/06/26 03:52	Vehicle Off Road	2026001423			Phone
01/06/26 19:29	Vehicle Off Road	2026001677			Officer
01/19/26 14:08	Vehicle Off Road	2026005428			Phone
01/22/26 14:46	Vehicle Off Road	2026006280			Phone
01/31/26 00:37	Vehicle Off Road	2026008672	Domestic Disturbance	WP26002679	911

Walk Away Total: 1

01/26/26 10:29	Walk Away	2026007336	Walk Away	WSRO26002295	
----------------	-----------	------------	-----------	--------------	--

Warrant - Arrest Total: 2

01/04/26 13:30	Warrant - Arrest	2026000945	Warrant - Attempt	WP26000283	Officer
01/26/26 20:42	Warrant - Arrest	2026007528	Warrant - Arrest	WP26002353	

Incident Start Date/Time	Initial Call	CFS #	Final Incident	Case Number	How Reported
--------------------------	--------------	-------	----------------	-------------	--------------

Warrant - Attempt Total: 4

01/12/26 14:05	Warrant - Attempt	2026003583			
01/24/26 21:15	Warrant - Attempt	2026006930			
01/26/26 21:35	Warrant - Attempt	2026007542			
01/27/26 20:33	Warrant - Attempt	2026007801			

Total Records: 1225

Monticello Patrol Hour Summary

Hours Purchased Per Contract:	21,900.00
Starting Hours (beginning of month):	21,900.00
M-T-D (detailed below):	1,867.75
Balance going forward (to next month):	20,032.25
Y-T-D:	1,867.75

** Estimated Hours not verified by final monthly payroll

Shift Start		Shift Stop						
Date	Shift Start Time	Shift Stop Date	Time	Schedule	Position	Time Type	Regular Hours	
1-Jan-26	18:00	2-Jan-26	4:00	Monticello (60)	3240 Sheriff Gener:		10	
1-Jan-26	16:00	2-Jan-26	2:00	Monticello (60)	3230 Sheriff Gener:		10	
1-Jan-26	8:00	1-Jan-26	14:15	Monticello (60)	3211 Sheriff Gener:		6.25	
1-Jan-26	14:15	1-Jan-26	18:00	Monticello (60)	3211 Sheriff Gener:		3.75	
1-Jan-26	10:00	1-Jan-26	20:00	Monticello (60)	3220 Sheriff Gener:		10	
1-Jan-26	6:00	1-Jan-26	16:00	Monticello (60)	3210 Sheriff Gener:		10	
1-Jan-26	20:00	2-Jan-26	6:00	Monticello (60)	3241 Sheriff Gener:		10	
2-Jan-26	18:00	3-Jan-26	6:00	Monticello (60)	3240 Sheriff Gener:		12	
2-Jan-26	18:30	2-Jan-26	20:00	Monticello (60)	3211 Sheriff Gener:		1.5	
2-Jan-26	16:00	2-Jan-26	18:30	Monticello (60)	3211 Sheriff Gener:		2.5	
2-Jan-26	8:00	2-Jan-26	12:00	Monticello (60)	3211 Sheriff Gener:		4	
2-Jan-26	10:00	2-Jan-26	18:00	Monticello (60)	3220 Sheriff Gener:		8	
2-Jan-26	12:00	2-Jan-26	16:00	Monticello (60)	3211 Sheriff Gener:		4	
2-Jan-26	18:00	2-Jan-26	22:00	Monticello (60)	3220 Sheriff Gener:		4	
2-Jan-26	6:00	2-Jan-26	18:00	Monticello (60)	3210 Sheriff Gener:		12	
2-Jan-26	6:00	2-Jan-26	6:45	Extra Hours: Mo	3241 EOS Premium		0.75	
2-Jan-26	18:00	3-Jan-26	6:00	Monticello (60)	3241 Sheriff Gener:		12	
3-Jan-26	18:00	4-Jan-26	6:00	Monticello (60)	3240 Sheriff Gener:		12	
3-Jan-26	16:00	3-Jan-26	20:00	Monticello (60)	3211 Sheriff Gener:		4	
3-Jan-26	10:00	3-Jan-26	22:00	Monticello (60)	3220 Sheriff Gener:		12	
3-Jan-26	6:00	3-Jan-26	18:00	Monticello (60)	3210 Sheriff Gener:		12	
3-Jan-26	8:00	3-Jan-26	16:00	Monticello (60)	3211 Sheriff Gener:		8	
3-Jan-26	18:00	4-Jan-26	6:00	Monticello (60)	3241 Sheriff Gener:		12	
4-Jan-26	8:00	4-Jan-26	20:00	Monticello (60)	3211 Sheriff Gener:		12	
4-Jan-26	10:00	4-Jan-26	22:00	Monticello (60)	3220 Sheriff Gener:		12	
4-Jan-26	18:00	5-Jan-26	6:00	Monticello (60)	3240 Sheriff Gener:		12	
4-Jan-26	18:00	5-Jan-26	6:00	Monticello (60)	3241 Sheriff Gener:		12	
4-Jan-26	6:00	4-Jan-26	18:00	Monticello (60)	3210 Sheriff Gener:		12	
5-Jan-26	8:00	5-Jan-26	20:00	Monticello (60)	3211 Sheriff Gener:		12	
5-Jan-26	10:00	5-Jan-26	22:00	Monticello (60)	3220 Sheriff Gener:		12	
5-Jan-26	6:00	5-Jan-26	6:30	Extra Hours: Mo	3241 Sheriff Premit		0.5	
5-Jan-26	18:00	6-Jan-26	6:00	Monticello (60)	3240 Sheriff Gener:		12	
5-Jan-26	18:00	6-Jan-26	6:00	Monticello (60)	3241 Sheriff Gener:		12	

5-Jan-26	6:00	5-Jan-26	18:00 Monticello (60)	3210 Sheriff Gener:	12
6-Jan-26	9:30	6-Jan-26	20:00 Monticello (60)	3211 Sheriff Gener:	10.5
6-Jan-26	10:00	6-Jan-26	22:00 Monticello (60)	3220 Sheriff Gener:	12
6-Jan-26	8:00	6-Jan-26	9:30 Monticello (60)	3211 Sheriff Gener:	1.5
6-Jan-26	18:00	7-Jan-26	6:00 Monticello (60)	3240 Sheriff Gener:	12
6-Jan-26	18:00	7-Jan-26	6:00 Monticello (60)	3241 Sheriff Gener:	12
6-Jan-26	6:00	6-Jan-26	18:00 Monticello (60)	3210 Sheriff Gener:	12
7-Jan-26	8:00	7-Jan-26	20:00 Monticello (60)	3211 Sheriff Gener:	12
7-Jan-26	10:00	7-Jan-26	22:00 Monticello (60)	3220 Sheriff Gener:	12
7-Jan-26	19:30	8-Jan-26	6:00 Monticello (60)	3240 Sheriff Gener:	10.5
7-Jan-26	18:00	8-Jan-26	6:00 Monticello (60)	3241 Sheriff Gener:	12
7-Jan-26	6:00	7-Jan-26	18:00 Monticello (60)	3210 Sheriff Gener:	12
7-Jan-26	18:00	7-Jan-26	19:30 Monticello (60)	3240 Sheriff Gener:	1.5
8-Jan-26	8:00	8-Jan-26	18:00 Monticello (60)	3211 Sheriff Gener:	10
8-Jan-26	10:00	8-Jan-26	22:00 Monticello (60)	3220 Sheriff Gener:	12
8-Jan-26	22:00	9-Jan-26	0:45 Extra Hours: Mo	3220 EOS Premium	2.75
8-Jan-26	18:00	9-Jan-26	6:00 Monticello (60)	3240 Sheriff Gener:	12
8-Jan-26	18:00	9-Jan-26	6:00 Monticello (60)	3241 Sheriff Gener:	12
8-Jan-26	6:00	8-Jan-26	18:00 Monticello (60)	3210 Sheriff Gener:	12
9-Jan-26	10:00	9-Jan-26	22:00 Monticello (60)	3220 Sheriff Gener:	12
9-Jan-26	6:00	9-Jan-26	7:45 Extra Hours: Mo	3240 EOS Premium	1.75
9-Jan-26	18:00	10-Jan-26	6:00 Monticello (60)	3240 Sheriff Gener:	12
9-Jan-26	8:00	9-Jan-26	20:00 Monticello (60)	3211 Sheriff Gener:	12
9-Jan-26	18:00	10-Jan-26	6:00 Monticello (60)	3241 Sheriff Gener:	12
9-Jan-26	6:00	9-Jan-26	18:00 Monticello (60)	3210 Sheriff Gener:	12
10-Jan-26	10:00	10-Jan-26	22:00 Monticello (60)	3220 Sheriff Gener:	12
10-Jan-26	18:00	11-Jan-26	6:00 Monticello (60)	3240 Sheriff Gener:	12
10-Jan-26	8:00	10-Jan-26	20:00 Monticello (60)	3211 Sheriff Gener:	12
10-Jan-26	18:00	11-Jan-26	6:00 Monticello (60)	3241 Sheriff Gener:	12
10-Jan-26	6:00	10-Jan-26	18:00 Monticello (60)	3210 Sheriff Gener:	12
11-Jan-26	10:00	11-Jan-26	22:00 Monticello (60)	3220 Sheriff Gener:	12
11-Jan-26	18:00	12-Jan-26	6:00 Monticello (60)	3240 Sheriff Gener:	12
11-Jan-26	8:00	11-Jan-26	20:00 Monticello (60)	3211 Sheriff Gener:	12
11-Jan-26	18:00	12-Jan-26	6:00 Monticello (60)	3241 Sheriff Gener:	12
11-Jan-26	6:00	11-Jan-26	18:00 Monticello (60)	3210 Sheriff Gener:	12
12-Jan-26	8:00	12-Jan-26	18:00 Monticello (60)	3211 Sheriff Gener:	10
12-Jan-26	10:00	12-Jan-26	20:00 Monticello (60)	3220 Sheriff Gener:	10
12-Jan-26	18:00	13-Jan-26	4:00 Monticello (60)	3240 Sheriff Gener:	10
12-Jan-26	16:00	12-Jan-26	20:00 Monticello (60)	3230 Sheriff Gener:	4
12-Jan-26	20:00	13-Jan-26	6:00 Monticello (60)	3241 Sheriff Gener:	10
12-Jan-26	20:00	13-Jan-26	2:00 Monticello (60)	3230 Sheriff Gener:	6
12-Jan-26	6:00	12-Jan-26	16:00 Monticello (60)	3210 Sheriff Gener:	10
13-Jan-26	8:00	13-Jan-26	18:00 Monticello (60)	3211 Sheriff Gener:	10
13-Jan-26	10:00	13-Jan-26	20:00 Monticello (60)	3220 Sheriff Gener:	10
13-Jan-26	18:00	14-Jan-26	4:00 Monticello (60)	3240 Sheriff Gener:	10
13-Jan-26	16:00	13-Jan-26	20:00 Monticello (60)	3230 Sheriff Gener:	4
13-Jan-26	20:00	14-Jan-26	6:00 Monticello (60)	3241 Sheriff Gener:	10

13-Jan-26	20:00	14-Jan-26	2:00 Monticello (60)	3230 Sheriff Gener:	6
13-Jan-26	6:00	13-Jan-26	16:00 Monticello (60)	3210 Sheriff Gener:	10
14-Jan-26	8:00	14-Jan-26	11:15 Monticello (60)	3211 Sheriff Gener:	3.25
14-Jan-26	14:00	14-Jan-26	20:45 Monticello (60)	3211 Sheriff Gener:	6.75
14-Jan-26	10:00	14-Jan-26	20:00 Monticello (60)	3220 Sheriff Gener:	10
14-Jan-26	18:00	15-Jan-26	4:00 Monticello (60)	3240 Sheriff Gener:	10
14-Jan-26	11:15	14-Jan-26	14:00 Monticello (60)	3211 Sheriff Gener:	2.75
14-Jan-26	20:00	15-Jan-26	6:00 Monticello (60)	3241 Sheriff Gener:	10
14-Jan-26	16:00	15-Jan-26	2:00 Monticello (60)	3230 Sheriff Gener:	10
14-Jan-26	6:00	14-Jan-26	16:00 Monticello (60)	3210 Sheriff Gener:	10
15-Jan-26	8:00	15-Jan-26	18:00 Monticello (60)	3211 Sheriff Gener:	10
15-Jan-26	10:00	15-Jan-26	20:00 Monticello (60)	3220 Sheriff Gener:	10
15-Jan-26	18:00	16-Jan-26	4:00 Monticello (60)	3240 Sheriff Gener:	10
15-Jan-26	20:00	16-Jan-26	6:00 Monticello (60)	3241 Sheriff Gener:	10
15-Jan-26	16:00	16-Jan-26	2:00 Monticello (60)	3230 Sheriff Gener:	10
15-Jan-26	6:00	15-Jan-26	16:00 Monticello (60)	3210 Sheriff Gener:	10
16-Jan-26	8:00	16-Jan-26	20:00 Monticello (60)	3211 Sheriff Gener:	12
16-Jan-26	18:00	17-Jan-26	6:00 Monticello (60)	3240 Sheriff Gener:	12
16-Jan-26	18:00	17-Jan-26	4:30 Monticello (60)	3241 Sheriff Gener:	10.5
16-Jan-26	6:00	16-Jan-26	18:00 Monticello (60)	3210 Sheriff Gener:	12
16-Jan-26	8:00	16-Jan-26	20:00 Monticello (60)	3220 Sheriff Gener:	12
17-Jan-26	8:00	17-Jan-26	18:30 Monticello (60)	3211 Sheriff Gener:	10.5
17-Jan-26	11:00	17-Jan-26	18:00 Monticello (60)	3210 Sheriff Gener:	7
17-Jan-26	18:30	17-Jan-26	20:00 Monticello (60)	3211 Sheriff Gener:	1.5
17-Jan-26	4:30	17-Jan-26	6:00 Monticello (60)	3241 Sheriff Gener:	1.5
17-Jan-26	10:00	17-Jan-26	22:00 Monticello (60)	3220 Sheriff Gener:	12
17-Jan-26	18:00	18-Jan-26	6:00 Monticello (60)	3240 Sheriff Gener:	12
17-Jan-26	18:00	18-Jan-26	6:00 Monticello (60)	3241 Sheriff Gener:	12
17-Jan-26	6:00	17-Jan-26	11:00 Monticello (60)	3210 Sheriff Gener:	5
18-Jan-26	20:00	18-Jan-26	22:00 Monticello (60)	3220 Sheriff Gener:	2
18-Jan-26	10:00	18-Jan-26	20:00 Monticello (60)	3220 Sheriff Gener:	10
18-Jan-26	18:00	19-Jan-26	6:00 Monticello (60)	3240 Sheriff Gener:	12
18-Jan-26	18:00	19-Jan-26	6:00 Monticello (60)	3241 Sheriff Gener:	12
18-Jan-26	6:00	18-Jan-26	18:00 Monticello (60)	3210 Sheriff Gener:	12
18-Jan-26	8:00	18-Jan-26	20:00 Monticello (60)	3211 Sheriff Gener:	12
19-Jan-26	8:00	19-Jan-26	20:00 Monticello (60)	3211 Sheriff Gener:	12
19-Jan-26	10:00	19-Jan-26	22:00 Monticello (60)	3220 Sheriff Gener:	12
19-Jan-26	18:00	20-Jan-26	6:00 Monticello (60)	3240 Sheriff Gener:	12
19-Jan-26	18:00	20-Jan-26	6:00 Monticello (60)	3241 Sheriff Gener:	12
19-Jan-26	6:00	19-Jan-26	18:00 Monticello (60)	3210 Sheriff Gener:	12
20-Jan-26	8:00	20-Jan-26	20:00 Monticello (60)	3211 Sheriff Gener:	12
20-Jan-26	10:00	20-Jan-26	22:00 Monticello (60)	3220 Sheriff Gener:	12
20-Jan-26	18:00	21-Jan-26	6:00 Monticello (60)	3240 Sheriff Gener:	12
20-Jan-26	18:00	21-Jan-26	6:00 Monticello (60)	3241 Sheriff Gener:	12
20-Jan-26	6:00	20-Jan-26	18:00 Monticello (60)	3210 Sheriff Gener:	12
21-Jan-26	8:00	21-Jan-26	20:00 Monticello (60)	3211 Sheriff Gener:	12
21-Jan-26	10:00	21-Jan-26	22:00 Monticello (60)	3220 Sheriff Gener:	12

21-Jan-26	18:00	22-Jan-26	6:00 Monticello (60)	3240 Sheriff Gener:	12
21-Jan-26	18:00	22-Jan-26	6:00 Monticello (60)	3241 Sheriff Gener:	12
21-Jan-26	6:00	21-Jan-26	18:00 Monticello (60)	3210 Sheriff Gener:	12
22-Jan-26	8:00	22-Jan-26	20:00 Monticello (60)	3211 Sheriff Gener:	12
22-Jan-26	10:00	22-Jan-26	22:00 Monticello (60)	3220 Sheriff Gener:	12
22-Jan-26	18:00	23-Jan-26	6:00 Monticello (60)	3240 Sheriff Gener:	12
22-Jan-26	6:00	22-Jan-26	18:00 Monticello (60)	3210 Sheriff Gener:	12
22-Jan-26	18:00	23-Jan-26	6:00 Monticello (60)	3241 Sheriff Gener:	12
23-Jan-26	8:00	23-Jan-26	20:00 Monticello (60)	3211 Sheriff Gener:	12
23-Jan-26	10:00	23-Jan-26	22:00 Monticello (60)	3220 Sheriff Gener:	12
23-Jan-26	18:00	24-Jan-26	6:00 Monticello (60)	3240 Sheriff Gener:	12
23-Jan-26	18:00	24-Jan-26	6:00 Monticello (60)	3241 Sheriff Gener:	12
23-Jan-26	6:00	23-Jan-26	18:00 Monticello (60)	3210 Sheriff Gener:	12
24-Jan-26	8:00	24-Jan-26	20:00 Monticello (60)	3211 Sheriff Gener:	12
24-Jan-26	10:00	24-Jan-26	22:00 Monticello (60)	3220 Sheriff Gener:	12
24-Jan-26	6:00	24-Jan-26	7:45 Extra Hours: Mo	3240 EOS Premium	1.75
24-Jan-26	18:00	25-Jan-26	6:00 Monticello (60)	3240 Sheriff Gener:	12
24-Jan-26	18:00	25-Jan-26	6:00 Monticello (60)	3241 Sheriff Gener:	12
24-Jan-26	6:00	24-Jan-26	18:00 Monticello (60)	3210 Sheriff Gener:	12
25-Jan-26	18:00	26-Jan-26	6:00 Monticello (60)	3240 Sheriff Gener:	12
25-Jan-26	8:00	25-Jan-26	20:00 Monticello (60)	3211 Sheriff Gener:	12
25-Jan-26	10:00	25-Jan-26	22:00 Monticello (60)	3220 Sheriff Gener:	12
25-Jan-26	6:00	25-Jan-26	7:30 Extra Hours: Mo	3241 EOS Premium	1.5
25-Jan-26	18:00	26-Jan-26	6:00 Monticello (60)	3241 Sheriff Gener:	12
25-Jan-26	6:00	25-Jan-26	18:00 Monticello (60)	3210 Sheriff Gener:	12
26-Jan-26	20:00	27-Jan-26	6:00 Monticello (60)	3240 Sheriff Gener:	10
26-Jan-26	10:00	26-Jan-26	18:00 Monticello (60)	3211 Sheriff Gener:	8
26-Jan-26	8:00	26-Jan-26	10:00 Monticello (60)	3211 Sheriff Gener:	2
26-Jan-26	10:00	26-Jan-26	20:00 Monticello (60)	3220 Sheriff Gener:	10
26-Jan-26	16:00	27-Jan-26	2:00 Monticello (60)	3230 Sheriff Gener:	10
26-Jan-26	20:00	27-Jan-26	6:00 Monticello (60)	3241 Sheriff Gener:	10
26-Jan-26	6:00	26-Jan-26	16:00 Monticello (60)	3210 Sheriff Gener:	10
27-Jan-26	20:00	28-Jan-26	6:00 Monticello (60)	3240 Sheriff Gener:	10
27-Jan-26	8:00	27-Jan-26	18:00 Monticello (60)	3211 Sheriff Gener:	10
27-Jan-26	10:00	27-Jan-26	20:00 Monticello (60)	3220 Sheriff Gener:	10
27-Jan-26	16:00	28-Jan-26	2:00 Monticello (60)	3230 Sheriff Gener:	10
27-Jan-26	20:00	28-Jan-26	6:00 Monticello (60)	3241 Sheriff Gener:	10
27-Jan-26	6:00	27-Jan-26	16:00 Monticello (60)	3210 Sheriff Gener:	10
28-Jan-26	8:00	28-Jan-26	18:00 Monticello (60)	3211 Sheriff Gener:	10
28-Jan-26	10:00	28-Jan-26	20:00 Monticello (60)	3220 Sheriff Gener:	10
28-Jan-26	18:00	29-Jan-26	4:00 Monticello (60)	3240 Sheriff Gener:	10
28-Jan-26	20:00	29-Jan-26	6:00 Monticello (60)	3241 Sheriff Gener:	10
28-Jan-26	16:00	29-Jan-26	2:00 Monticello (60)	3230 Sheriff Gener:	10
28-Jan-26	6:00	28-Jan-26	16:00 Monticello (60)	3210 Sheriff Gener:	10
29-Jan-26	8:00	29-Jan-26	18:00 Monticello (60)	3211 Sheriff Gener:	10
29-Jan-26	10:00	29-Jan-26	20:00 Monticello (60)	3220 Sheriff Gener:	10
29-Jan-26	18:00	30-Jan-26	4:00 Monticello (60)	3240 Sheriff Gener:	10

29-Jan-26	20:00	30-Jan-26	6:00 Monticello (60)	3241 Sheriff Gener:	10
29-Jan-26	16:00	30-Jan-26	2:00 Monticello (60)	3230 Sheriff Gener:	10
29-Jan-26	6:00	29-Jan-26	16:00 Monticello (60)	3210 Sheriff Gener:	10
30-Jan-26	8:00	30-Jan-26	20:00 Monticello (60)	3211 Sheriff Gener:	12
30-Jan-26	10:00	30-Jan-26	22:00 Monticello (60)	3220 Sheriff Gener:	12
30-Jan-26	18:00	31-Jan-26	6:00 Monticello (60)	3240 Sheriff Gener:	12
30-Jan-26	6:00	30-Jan-26	18:00 Monticello (60)	3210 Sheriff Gener:	12
30-Jan-26	18:00	31-Jan-26	6:00 Monticello (60)	3241 Sheriff Gener:	12
31-Jan-26	12:15	31-Jan-26	20:00 Monticello (60)	3211 Sheriff Gener:	7.75
31-Jan-26	10:00	31-Jan-26	12:15 Monticello (60)	3211 Sheriff Gener:	2.25
31-Jan-26	10:00	31-Jan-26	22:00 Monticello (60)	3220 Sheriff Gener:	12
31-Jan-26	18:00	1-Feb-26	6:00 Monticello (60)	3240 Sheriff Gener:	12
31-Jan-26	18:00	1-Feb-26	6:00 Monticello (60)	3241 Sheriff Gener:	12
31-Jan-26	6:00	31-Jan-26	18:00 Monticello (60)	3210 Sheriff Gener:	12

TOTAL: 1,867.75



State Aid Funding Advancement

February 9, 2026

MN State Aid Funding Overview

- Municipal State Aid System (MSAS) Funding is generated from the Highway User Tax Distribution Fund (HUTDF).
 - 9% of HUTDF funds are allocated to the MSAS system.
 - HUTDF funding includes state gas tax, vehicle registration fees, and a portion of the motor vehicles sales tax.
- Cities with a population over 5,000 are eligible to receive MSAS funding.
 - In 2025, there were 155 State-Aid Cities.
- Funding is distributed 50% based on population and 50% based on need.
- Need for roadway maintenance is estimated based on traffic volumes and is calculated by the Municipal Screening Board.

MN State Aid Funding Overview

- State allots funding annually and sets it aside in an account for each jurisdiction.
- State allows Cities to request funding from their account (“advance”) up to 4 future years.

For example, in 2026, a city can request payment for:

- 1) the balance from any unused allotment in previous years as well as the current year
- 2) the future allotments from 2027-2030

MN State Aid Process

- Each year, the City certifies the maintained mileage by adding any newly constructed public roadways within the City and proposing any changes for streets to be included.
 - 20% of the total mileage of roadways maintained by the City are allowed to be included.
- When a City completes a project on an eligible street, it can request reimbursement from the State out of its “account”.
- If MSAS funds are used on a project, the street must be maintained on the State-Aid system for 25-years for a reconstruction project or 10-years for an overlay.

MN State Aid – Monticello Streets

- In 2020 an audit of the MSAS system was completed which determined that Monticello was eligible for an additional 1.8 miles in MSAS routes. Chelsea Road between CSAH 39 and Hwy 25 was added to the system with this change.
- Other recent system changes include the addition of 7th Street between Golf Course Road and Elm Street with the removal of East River Street.
 - 7th Street generated additional need in the funding formula due to having higher traffic volumes.

MN State Aid – Monticello Funding

- Monticello received an advance of state aid in 2023, which was essentially for 2023-2027's allotments (i.e. our account currently has a “negative” balance).
- Monticello previously completed projects which were paid for with city funds and still have eligible costs to be reimbursed by State Aid funding.
- Council's requested action to adopt the resolution would further “advance” the City's State Aid allotments for 2028-2030.

Questions?



TH 25 and I-94 Bridge MNDOT Agreement

February 9, 2026

Agreement Overview

- MNDOT has a bridge re-decking project planned for 2027.
- Sidewalk will also be widened from 6' to 8' wide.
- Bridge will be closed for deck and sidewalk replacement.
 - 4-month estimated construction timeline
 - NB detour utilizing Broadway Street/Fenning Avenue/School Boulevard
 - SB detour utilizing Chelsea Road/Fallon Avenue /7th Street
- MNDOT cost participation policy update proposes to move construction cost participation more towards MNDOT with some maintenance items being city and county responsibilities.

Agreement Overview

- City responsibility per this agreement includes:
 - Sidewalk maintenance
 - Snow and ice removal
 - Debris removal
 - Crack repair and patching
 - Pedestrian ramp upkeep
 - Grass boulevard mowing & other maintenance responsibilities
 - Lighting system
 - LED re-lamping and replacement
 - Pole and luminaire repairs
 - Electrical cabinet and distribution maintenance
 - Conduit repairs and wiring replacement
 - Utility locates
 - Electrical service costs

Agreement Overview

- City responsibilities continued:
 - Aesthetic features
 - Painting
 - Graffiti removal
 - Replacement and upkeep of emblems
- Costs
 - No local construction match is expected. MNDOT allows 7% of construction for aesthetic upgrades.
 - Maintenance cost, including electrical service, sidewalk repair, and maintenance, is expected at \$15,000 annually.

Lighting System

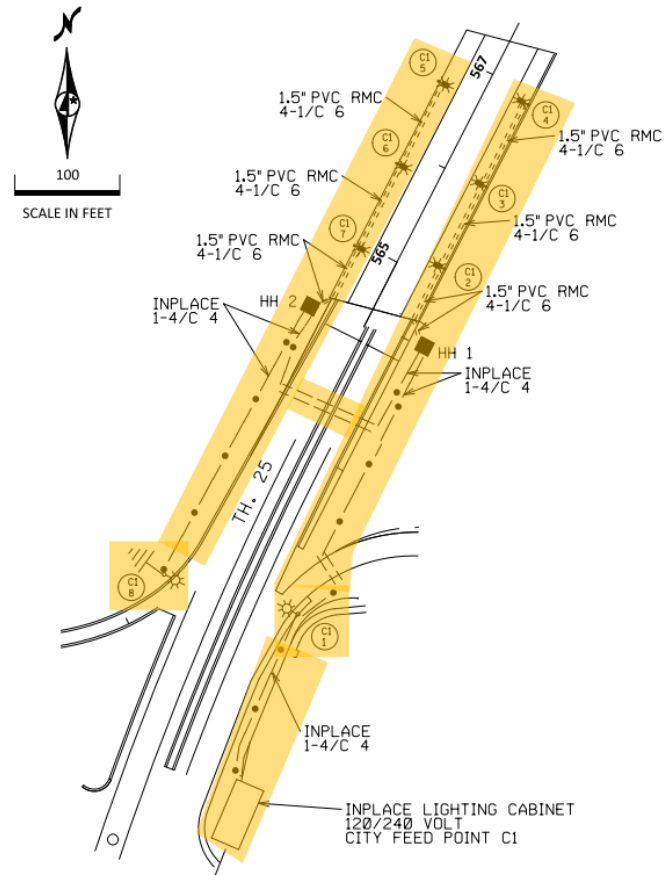

Concrete Emblem

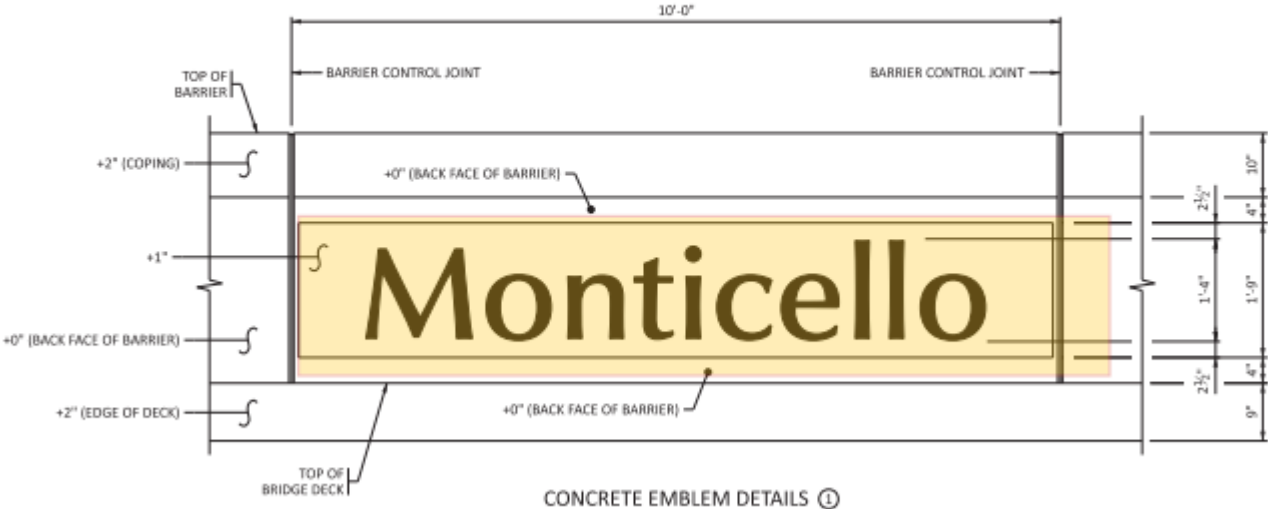

Metal Railing

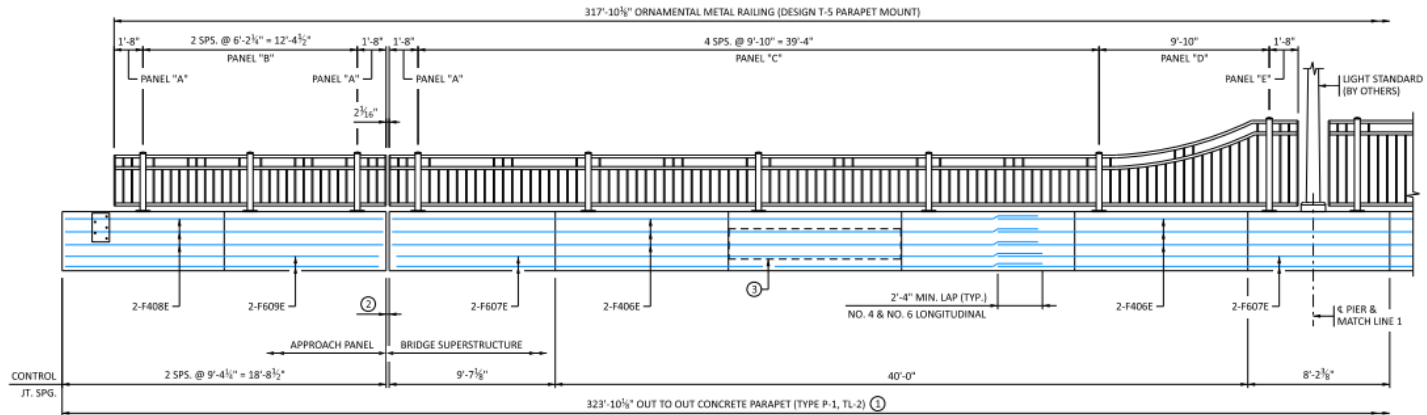

SOUTH END OF WEST BARRIER

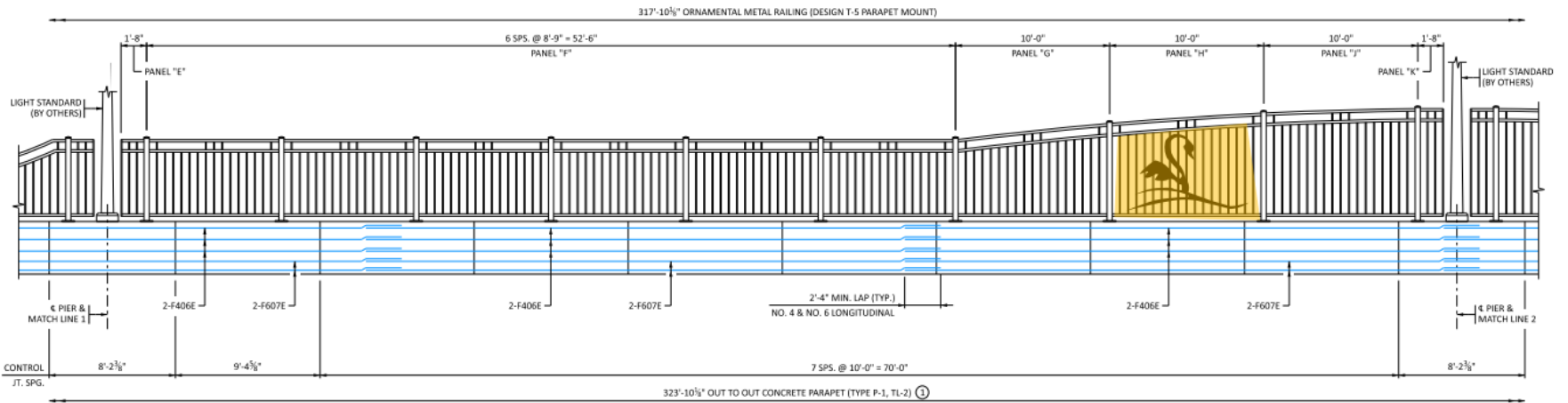

INSIDE ELEVATION CONCRETE PARAPET & ORNAMENTAL RAILING

WEST BARRIER SHOWN (EAST BARRIER SIMILAR)

NOTES:

Metal Railing

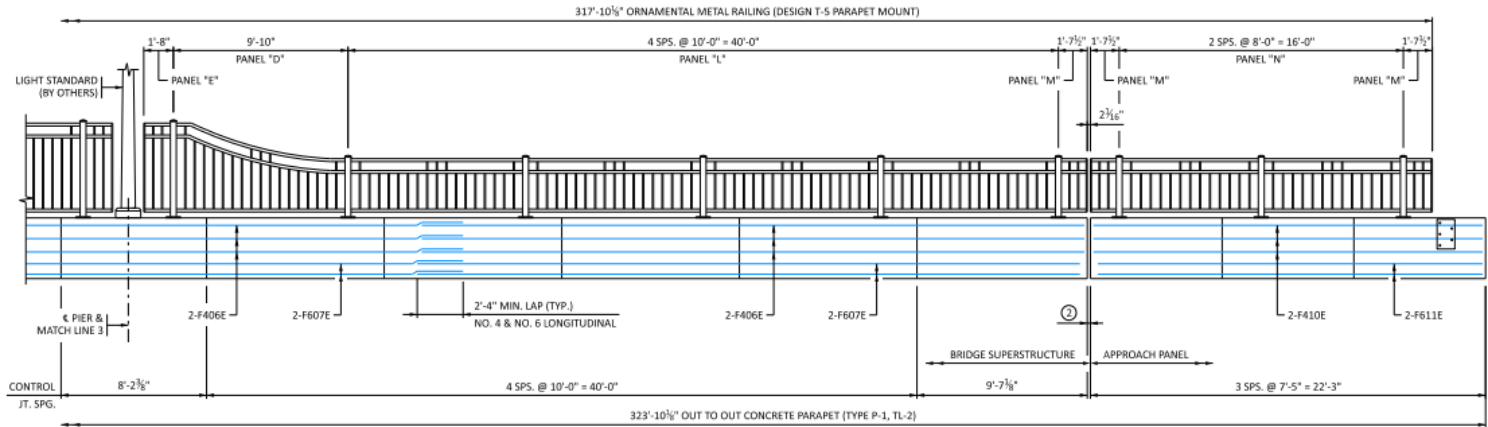
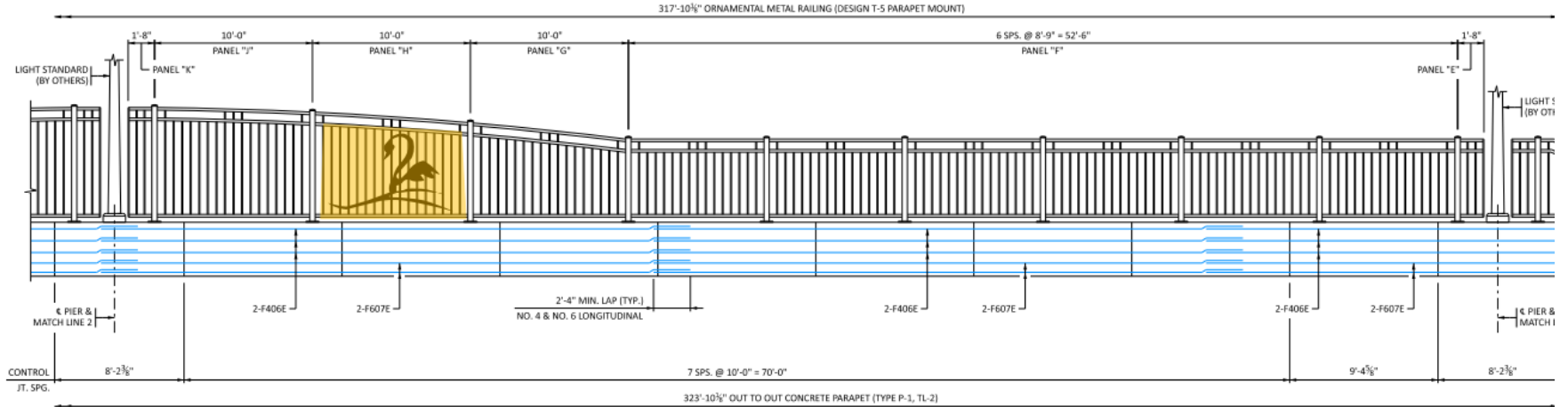

INSIDE ELEVATION CONCRETE PARAPET & ORNAMENTAL RAILING

WEST BARRIER SHOWN (EAST BARRIER SIMILAR)

NOTES:

NORTH END OF WEST BARRIER

Questions?